

# WebSphere Application Server for i5/OS Handbook: Version 6.1

Designed to be the ultimate resource  
for WebSphere support personnel

Covers both Base and Network  
Deployment editions

Contains tips to make your  
work more efficient



Aleksandr V. Nartovich  
Juan Manuel Alcudia  
Norman Bels  
Michael Fiebig  
Rafal Jablonski  
Heather R. Jones  
Adam Smye-Rumsby

**Redbooks**





International Technical Support Organization

**WebSphere Application Server for i5/OS Handbook:  
Version 6.1**

March 2008

**Note:** Before using this information and the product it supports, read the information in “Notices” on page ix.

**First Edition (March 2008)**

This edition applies to Version 6.1 of WebSphere Application Server for i5/OS (product number 5733W61).

© Copyright International Business Machines Corporation 2008. All rights reserved.

Note to U.S. Government Users Restricted Rights -- Use, duplication or disclosure restricted by GSA ADP Schedule Contract with IBM Corp.

# Contents

<b>Notices</b> .....	ix
Trademarks .....	x
<b>Preface</b> .....	xi
The team that wrote this book .....	xi
Become a published author .....	xiii
Comments welcome .....	xiii
<b>Chapter 1. System i platform and WebSphere Application Server</b> .....	1
1.1 Overview of WebSphere Application Server Version 6.1 for i5/OS .....	2
1.1.1 Runtime environment .....	2
1.1.2 Hardware and software requirements .....	2
1.1.3 Administration tools .....	4
1.1.4 Development tools .....	7
1.1.5 Platform differences .....	8
1.2 WebSphere Application Server Version 6.1 for i5/OS enhancements .....	9
1.2.1 Installation enhancements .....	10
1.2.2 Default installation root changes .....	12
1.2.3 Administration enhancements .....	13
1.2.4 Application development enhancements .....	13
1.2.5 Application Server Toolkit (AST) enhancements .....	14
1.2.6 Performance and tuning enhancements .....	14
1.2.7 Security enhancements .....	15
<b>Chapter 2. Planning for WebSphere Application Server installation</b> .....	17
2.1 Choosing a WebSphere Application Server edition .....	18
2.2 System i model recommendations .....	18
2.2.1 Processor recommendations .....	18
2.2.2 Memory recommendations .....	18
2.2.3 Storage requirements .....	19
2.2.4 Communications requirements .....	20
2.3 Sizing your system with IBM Workload Estimator .....	20
2.4 Topologies for WebSphere Application Server .....	21
2.4.1 Basic standalone topology .....	22
2.4.2 Remote Web server topology .....	22
2.4.3 Three-tier topology .....	23
2.4.4 High availability topology .....	24
2.5 Additional pre-installation considerations .....	25
<b>Chapter 3. Installing WebSphere Application Server</b> .....	31
3.1 Installation checklist .....	32
3.2 Prerequisites for WebSphere Application Server on i5/OS .....	32
3.2.1 System i hardware requirements .....	33
3.2.2 System i and i5/OS software requirements .....	33
3.2.3 i5/OS optional software .....	34
3.3 Preparing i5/OS for installation .....	35
3.3.1 Install prerequisite program temporary fixes .....	35
3.3.2 Checking TCP/IP configuration .....	37
3.3.3 Checking your user profile authorization .....	38

3.4	Performing WebSphere Application Server installation. . . . .	38
3.4.1	Remote GUI installation . . . . .	38
3.4.2	Silent installation . . . . .	48
3.5	Optional software components associated with WebSphere Application Server . . . . .	52
3.6	Installing the latest recommended WebSphere Application Server fixes . . . . .	53
3.6.1	Installing the WebSphere Group PTF . . . . .	53
3.6.2	Installing the Update Installer . . . . .	54
3.6.3	Applying WebSphere Application Server fixes . . . . .	54
3.7	Performing post installation tasks . . . . .	56
3.7.1	Entering license information . . . . .	56
3.7.2	Verifying TCP/IP configuration . . . . .	57
3.7.3	Verifying the installation directories. . . . .	57
3.7.4	Configuring SQL jobs . . . . .	58
3.7.5	Verifying WebSphere Application Server installation . . . . .	60
3.8	IBM Installation Factory. . . . .	61
3.8.1	Installing IBM Installation Factory . . . . .	61
3.8.2	Using IBM Installation Factory . . . . .	62
3.9	Troubleshooting the WebSphere Application Server 6.1 installation . . . . .	77
3.9.1	Connection failed . . . . .	77
3.9.2	Security issues . . . . .	78
3.9.3	Prerequisite check failed. . . . .	79
3.9.4	Silent install problems . . . . .	79
3.9.5	Miscellaneous problems . . . . .	80
3.9.6	Where to find the logs . . . . .	80
3.9.7	Recovering from a failed install. . . . .	82
3.10	Uninstalling WebSphere Application Server . . . . .	82
<b>Chapter 4. Day-to-day operations . . . . .</b>		<b>85</b>
4.1	Overview of the WebSphere profiles. . . . .	86
4.1.1	Types of profiles . . . . .	86
4.1.2	Profile directory structure . . . . .	87
4.2	Day-to-day administration . . . . .	88
4.2.1	Starting IBM Web Administration for i5/OS. . . . .	89
4.2.2	Creating an application server profile . . . . .	92
4.2.3	Starting an application server . . . . .	107
4.2.4	Stopping an application server . . . . .	113
4.2.5	Running QShell scripts from the profile's home directory . . . . .	120
4.2.6	Accessing the WebSphere Administrative Console . . . . .	121
4.2.7	Listing the existing WebSphere profiles . . . . .	126
4.2.8	Deleting an application server profile . . . . .	127
4.2.9	Creating an application server cell . . . . .	134
4.2.10	Working with application server log files. . . . .	143
4.2.11	Discovering TCP/IP ports assigned to the profile . . . . .	151
4.2.12	Working with virtual hosts . . . . .	156
4.2.13	Auto-starting WebSphere Application Server . . . . .	159
<b>Chapter 5. Working with HTTP servers in WebSphere Application Server environment</b>		<b>163</b>
5.1	Overview of Web servers in a WebSphere Application Server environment . . . . .	164
5.1.1	Local Web server topology (stand-alone server) . . . . .	165
5.1.2	Remote Web server topology (stand-alone server) . . . . .	166
5.2	Configuring a local Web server with WebSphere Application Server . . . . .	167
5.3	Configuring a remote Web server with WebSphere Application Server . . . . .	171
5.3.1	Installing the Web server plug-in on the remote Web server . . . . .	172

5.3.2	Creating an instance of IBM HTTP Server for i5/OS . . . . .	177
5.3.3	Creating a non-default HTTP server profile . . . . .	180
5.3.4	Associating the Web server instance and Web server profile . . . . .	180
5.3.5	Creating a Web server definition in the WebSphere profile . . . . .	181
5.3.6	Propagating the plug-in configuration file to the Web server . . . . .	182
5.4	Verifying the Web server configuration . . . . .	186
5.5	Configuring additional Web server definitions . . . . .	186
5.6	Adding a Web server definition to a cell profile . . . . .	187
5.7	Managing IBM HTTP Server from the WebSphere Administrative Console . . . . .	194
5.7.1	Preparing the Web server for remote management . . . . .	194
5.7.2	Working with Web server configuration files from the WebSphere Administrative Console . . . . .	196
5.7.3	Working with Web server log files . . . . .	198
<b>Chapter 6.</b>	<b>Working with applications . . . . .</b>	<b>201</b>
6.1	Overview of developing and deploying J2EE applications . . . . .	202
6.1.1	Application design . . . . .	202
6.1.2	Application development . . . . .	202
6.1.3	Application packaging . . . . .	203
6.1.4	Application deployment . . . . .	203
6.1.5	The flow of a J2EE application . . . . .	204
6.2	Managing applications in WebSphere Application Server V6.1 . . . . .	206
6.2.1	Using the WebSphere administrative console to manage applications . . . . .	206
6.2.2	Installing an enterprise application . . . . .	208
6.2.3	Uninstalling an enterprise application . . . . .	209
6.2.4	Exporting an enterprise application . . . . .	209
6.2.5	Starting an enterprise application . . . . .	209
6.2.6	Stopping an enterprise application . . . . .	210
6.2.7	Preventing an enterprise application from auto-starting . . . . .	210
6.2.8	Viewing application deployment details . . . . .	210
6.2.9	Determining the URL of a servlet or JSP . . . . .	213
<b>Chapter 7.</b>	<b>Using WebSphere administrative (wsadmin) scripting . . . . .</b>	<b>217</b>
7.1	Developing automation scripts . . . . .	218
7.1.1	Execution environment . . . . .	219
7.2	Invoking wsadmin . . . . .	220
7.2.1	Running wsadmin script files . . . . .	222
7.3	Using wsadmin help . . . . .	223
7.4	WebSphere Application Server Toolkit . . . . .	224
7.4.1	Starting the WebSphere Application Server Toolkit (AST) . . . . .	224
7.4.2	Creating a server connection . . . . .	225
7.4.3	Creating a Jython Project . . . . .	228
7.4.4	Creating a Jython script file . . . . .	230
7.4.5	Generating WebSphere administrative commands to assist in developing Jython scripts . . . . .	231
7.4.6	Getting content assistance and tips in the Jython editor . . . . .	236
7.4.7	Migrating administrative Jacl scripts to Jython . . . . .	236
7.4.8	Exporting Jython scripts . . . . .	238
<b>Chapter 8.</b>	<b>Turning on security . . . . .</b>	<b>241</b>
8.1	Administrative security . . . . .	242
8.1.1	Enabling administrative security after installation . . . . .	242
8.1.2	Disabling administrative security . . . . .	245
8.2	Enabling SSL . . . . .	246

8.2.1	Overview of the sample environment . . . . .	247
8.3	Configuring SSL between a Web server and WebSphere Application Server . . . . .	248
8.3.1	Creating an application server profile on WebSphere Application Server system	249
8.3.2	Creating an HTTP WebSphere profile on the remote Web server system . . . . .	250
8.3.3	Creating an IBM HTTP server instance on the remote Web server and associating it with the HTTP server profile . . . . .	250
8.3.4	Creating the Web server definition on the application server system . . . . .	253
8.3.5	Adding the user profile and password for administering the HTTP server installation to the Web server definition . . . . .	255
8.3.6	Creating a virtual host alias for the remote Web server . . . . .	256
8.3.7	Regenerating and propagating the plug-in configuration file. . . . .	257
8.3.8	Verifying the configuration . . . . .	258
8.3.9	Checking messages in http_plugin.log . . . . .	258
8.3.10	Additional configuration required for WebSphere Application Server plug-in . . . . .	260
8.3.11	Enabling the secure transport between the Web server and the application server systems. . . . .	260
8.3.12	Verifying that the secure transport is working . . . . .	262
8.4	Configuring SSL between the Web Browser and the HTTP Server . . . . .	263
8.4.1	Creating your own SSL certificate. . . . .	264
8.4.2	Enabling SSL in your HTTP server instance. . . . .	279
8.4.3	Adding a virtual host for SSL to WebSphere Application Server . . . . .	282
8.4.4	Assigning a certificate to the HTTP server instance . . . . .	283
8.4.5	Testing the SSL configuration. . . . .	286
<b>Chapter 9.</b>	<b>Performance monitoring and tuning. . . . .</b>	<b>289</b>
9.1	Performance checklist. . . . .	290
9.1.1	Server hardware resources. . . . .	290
9.1.2	Applying the latest PTFs. . . . .	290
9.1.3	Isolating the WebSphere Application Server workload . . . . .	291
9.1.4	System values for an optimum operating system environment. . . . .	291
9.1.5	System wide performance-related commands . . . . .	292
9.1.6	Choosing a JVM to use for best performance. . . . .	293
9.1.7	Analysis and tuning for the Classic JVM. . . . .	294
9.1.8	Analyzing and tuning for IBM Technology for Java VM . . . . .	295
9.1.9	WebSphere queuing tips. . . . .	295
9.1.10	Database tuning . . . . .	297
9.1.11	Stress test to identify system thresholds and bottlenecks. . . . .	297
9.2	System i configuration. . . . .	298
9.2.1	Disk configuration . . . . .	298
9.2.2	Using system commands . . . . .	299
9.2.3	Isolating the WebSphere Application Server workload . . . . .	303
9.2.4	Setting heap size for WebSphere Application Server . . . . .	306
9.3	Classic JVM tools . . . . .	308
9.3.1	Verbose Garbage Collection. . . . .	308
9.3.2	DMPJVM. . . . .	310
9.3.3	Analyzing object growth using ANZJVM. . . . .	310
9.4	IBM Technology for Java VM tools . . . . .	311
9.4.1	Verbose Garbage Collector output . . . . .	311
9.4.2	Using Extensible Verbose GC toolkit to monitor garbage collection. . . . .	311
9.4.3	Javacore/Java dump. . . . .	323
9.4.4	ThreadAnalyzer. . . . .	324
9.4.5	Heapdump . . . . .	327
9.4.6	Memory Dump Diagnostic for Java (MDD4J) . . . . .	328

9.5 Analyzing a WebSphere Application Server JVM using PEX . . . . .	331
9.6 Using Tivoli Performance Viewer with WebSphere Application Server. . . . .	332
9.6.1 Monitoring thread pools . . . . .	333
9.6.2 Monitoring the connection pool . . . . .	336
9.6.3 JDBC performance considerations . . . . .	338
9.7 Web performance management tools . . . . .	339
9.7.1 Web Performance Monitor . . . . .	340
9.7.2 Web Performance Advisor . . . . .	346
<b>Chapter 10. Backup and recovery . . . . .</b>	<b>363</b>
10.1 Understanding your environment . . . . .	364
10.2 Locating your files . . . . .	364
10.3 Saving WebSphere Application Server . . . . .	366
10.3.1 QSYS.LIB objects . . . . .	366
10.3.2 IFS files . . . . .	369
10.4 Backing up WebSphere Application Server Network Deployment . . . . .	372
10.5 Saving additional licensed products . . . . .	373
10.6 Saving your database . . . . .	375
10.7 Frequency of backups . . . . .	375
10.7.1 WebSphere Application Server licensed products . . . . .	376
10.7.2 WebSphere Application Server environment configuration. . . . .	376
10.7.3 WebSphere Application Server applications . . . . .	376
10.7.4 WebSphere Application Server application data . . . . .	376
10.8 Recovery from a failure . . . . .	376
10.8.1 WebSphere Application Server licensed product . . . . .	377
10.8.2 WebSphere Application Server configuration . . . . .	377
10.8.3 Restoring authorizations . . . . .	377
10.8.4 WebSphere Application Server application data . . . . .	378
<b>Chapter 11. Running WebSphere Application Server with IBM Technology for Java VM</b>	<b>379</b>
11.1 Why two JVMs . . . . .	380
11.2 System requirements for i5/OS . . . . .	380
11.3 Switching between JVMs in WebSphere Application Server 6.1 . . . . .	381
11.3.1 The enableJVM script . . . . .	381
11.3.2 Enabling an existing WebSphere Application Server profile with IBM Technology for JVM. . . . .	382
11.3.3 Configuring WebSphere Application Server Network Deployment to use IBM Technology for Java VM . . . . .	384
11.3.4 Troubleshooting enableJVM for WebSphere Application Server Network Deployment. . . . .	387
11.3.5 Determining the JVM in use . . . . .	389
11.4 Configuring the WebSphere Application Server JVM . . . . .	391
11.5 Monitoring the WebSphere Application Server JVM . . . . .	393
11.5.1 Monitoring with Tivoli Performance Viewer . . . . .	393
11.6 Verbose Garbage Collection and logging . . . . .	397
11.7 Additional information . . . . .	398
<b>Appendix A. Downloading PTFs using Fix Central . . . . .</b>	<b>399</b>
Ordering your PTFs . . . . .	400
Moving your PTFs to an i5/OS system . . . . .	404
Installing your PTFs . . . . .	407
Directly downloading and installing the PTFs to an i5/OS system . . . . .	409

<b>Appendix B. WebSphere fix maintenance</b> .....	413
Installing individual fixes .....	414
Uninstalling fixes .....	416
The historyInfo script .....	416
Verifying the fix level .....	417
<b>Appendix C. IBM Support Assistant</b> .....	421
Overview of IBM Support Assistant .....	422
Installing IBM Support Assistant .....	422
Prerequisites .....	422
Downloading IBM Support Assistant from the Web .....	423
Configuring and updating IBM Support Assistant .....	424
Uninstalling IBM Support Assistant .....	426
Using IBM Support Assistant .....	427
Starting IBM Support Assistant .....	427
Starting JVM tools .....	427
Searching for WebSphere Application Server support information .....	428
Searching for WebSphere Application Server product Web sites .....	429
Submitting a problem report to IBM .....	429
Troubleshooting IBM Support Assistant .....	431
<b>Appendix D. Data to collect before you contact IBM Support</b> .....	433
System commands .....	434
WebSphere Application Server files .....	435
WebSphere Application Server tools .....	435
Working with trace .....	436
Additional IBM support resources .....	437
<b>Appendix E. Web enablement using IBM Express Runtime Web Environments for i5/OS</b>	
439	
Overview of IBM Express Runtime Web Environments for i5/OS .....	440
Web Enablement Environment .....	440
Ordering and distribution .....	441
System prerequisites .....	441
Installing IBM Express Runtime Web Environments for i5/OS .....	443
Deploying IBM Express Runtime Web Environments for i5/OS .....	447
FirstSteps .....	448
IBM Web Administration for i5/OS .....	449
iSeries Access for Web .....	449
Sample applications .....	450
Using IBM Express Runtime Web Environments for i5/OS .....	450
Troubleshooting IBM Express Runtime Web Environments for i5/OS .....	451
For Business Partners and ISVs: Applying the IBM Express Runtime Web Environments for i5/OS concept to your business .....	451
Solution Assembly Toolkit .....	452
Starting Point Solution Installers .....	454
<b>Related publications</b> .....	457
IBM Redbooks .....	457
Online resources .....	457
How to get IBM Redbooks .....	458
Help from IBM .....	458
<b>Index</b> .....	459

# Notices

This information was developed for products and services offered in the U.S.A.

IBM may not offer the products, services, or features discussed in this document in other countries. Consult your local IBM representative for information on the products and services currently available in your area. Any reference to an IBM product, program, or service is not intended to state or imply that only that IBM product, program, or service may be used. Any functionally equivalent product, program, or service that does not infringe any IBM intellectual property right may be used instead. However, it is the user's responsibility to evaluate and verify the operation of any non-IBM product, program, or service.

IBM may have patents or pending patent applications covering subject matter described in this document. The furnishing of this document does not give you any license to these patents. You can send license inquiries, in writing, to:

*IBM Director of Licensing, IBM Corporation, North Castle Drive, Armonk, NY 10504-1785 U.S.A.*

**The following paragraph does not apply to the United Kingdom or any other country where such provisions are inconsistent with local law:** INTERNATIONAL BUSINESS MACHINES CORPORATION PROVIDES THIS PUBLICATION "AS IS" WITHOUT WARRANTY OF ANY KIND, EITHER EXPRESS OR IMPLIED, INCLUDING, BUT NOT LIMITED TO, THE IMPLIED WARRANTIES OF NON-INFRINGEMENT, MERCHANTABILITY OR FITNESS FOR A PARTICULAR PURPOSE. Some states do not allow disclaimer of express or implied warranties in certain transactions, therefore, this statement may not apply to you.

This information could include technical inaccuracies or typographical errors. Changes are periodically made to the information herein; these changes will be incorporated in new editions of the publication. IBM may make improvements and/or changes in the product(s) and/or the program(s) described in this publication at any time without notice.

Any references in this information to non-IBM Web sites are provided for convenience only and do not in any manner serve as an endorsement of those Web sites. The materials at those Web sites are not part of the materials for this IBM product and use of those Web sites is at your own risk.

IBM may use or distribute any of the information you supply in any way it believes appropriate without incurring any obligation to you.

Information concerning non-IBM products was obtained from the suppliers of those products, their published announcements or other publicly available sources. IBM has not tested those products and cannot confirm the accuracy of performance, compatibility or any other claims related to non-IBM products. Questions on the capabilities of non-IBM products should be addressed to the suppliers of those products.

This information contains examples of data and reports used in daily business operations. To illustrate them as completely as possible, the examples include the names of individuals, companies, brands, and products. All of these names are fictitious and any similarity to the names and addresses used by an actual business enterprise is entirely coincidental.

## COPYRIGHT LICENSE:

This information contains sample application programs in source language, which illustrate programming techniques on various operating platforms. You may copy, modify, and distribute these sample programs in any form without payment to IBM, for the purposes of developing, using, marketing or distributing application programs conforming to the application programming interface for the operating platform for which the sample programs are written. These examples have not been thoroughly tested under all conditions. IBM, therefore, cannot guarantee or imply reliability, serviceability, or function of these programs.

# Trademarks

The following terms are trademarks of the International Business Machines Corporation in the United States, other countries, or both:

AIX®	eServer™	Redbooks®
alphaWorks®	iSeries®	Redbooks (logo)  ®
AS/400e™	i5/OS®	System i™
AS/400®	IBM®	System i5™
ClearCase®	Lotus®	System p™
Cloudscape®	MQSeries®	System x™
Domino®	NetServer™	Tivoli®
DB2 Universal Database™	Operating System/400®	WebSphere®
DB2®	OS/400®	Workplace™
developerWorks®	PartnerWorld®	z/OS®
Electronic Service Agent™	POWER5™	
Enterprise Workload Manager™	Rational®	

The following terms are trademarks of other companies:

Adobe, and Portable Document Format (PDF) are either registered trademarks or trademarks of Adobe Systems Incorporated in the United States, other countries, or both.

Enterprise JavaBeans, EJB, Java, Java Naming and Directory Interface, JavaBeans, JavaMail, JavaScript, JavaServer, JavaServer Pages, JDBC, JDK, JMX, JRE, JSP, JVM, J2EE, J2SE, Solaris, Streamline, and all Java-based trademarks are trademarks of Sun Microsystems, Inc. in the United States, other countries, or both.

Internet Explorer, Microsoft, SQL Server, Windows Server, Windows, and the Windows logo are trademarks of Microsoft Corporation in the United States, other countries, or both.

Intel, Pentium, Intel logo, Intel Inside logo, and Intel Centrino logo are trademarks or registered trademarks of Intel Corporation or its subsidiaries in the United States, other countries, or both.

UNIX is a registered trademark of The Open Group in the United States and other countries.

Linux is a trademark of Linus Torvalds in the United States, other countries, or both.

Other company, product, or service names may be trademarks or service marks of others.

# Preface

The number of System i™ customers running one or more Web applications is growing quickly. By integrating WebSphere Application Server - Express to i5/OS®, IBM® opens a door to a world of Web applications for all System i customers. Establishing solid knowledge and best practices in installing, administering, and maintaining WebSphere Application Server becomes one of the most important tasks for the System i administrators and support personnel.

In this IBM Redbooks® publication, we explore the latest WebSphere Application Server version to date, Version 6.1. We include instructions for performing numerous tasks around WebSphere Application Server for i5/OS: installing the product, working with the server and applications, tuning the performance, setting up security, and more. We strongly recommend this book for any technical professional who works with WebSphere Application Server. We designed this publication to help system architects, WebSphere® administrators, and software developers.

## The team that wrote this book

A team of specialists from around the world working at the International Technical Support Organization, Rochester Center produced this IBM Redbooks publication.

**Aleksandr V. Nartovich** is a Senior I/T Specialist in the ITSO, Rochester Center. He joined the ITSO in January 2001 after working as a Developer in the IBM WebSphere Business Components organization. During the first part of his career, Aleksandr was a Developer in AS/400® communications. Later, he shifted his focus to business components development on WebSphere. Aleksandr has a degree in computer science from the University of Missouri-Kansas City and a degree in electrical engineering from Minsk Radio Engineering Institute.

**Juan Manuel Alcudia** is an IBM Certified IT Specialist on iSeries®. He worked for TRENTISA, an IBM Business Partner, in Madrid, Spain. In June 2007, Juan joined Software Services at IBM Spain. His responsibilities include designing and implementing System i and WebSphere solutions. Juan Manuel has a degree in Computer Science from Polytechnic University of Madrid.

**Norman Bels** is a senior Technical Consultant in the IBM Innovation Centre for Business Partners in Sydney, Australia. Norman works with business partners, assisting them to port and test their applications to IBM hardware and software platforms. Currently Norman specializes in the areas of WebSphere and System i and has certifications in Rational® Application Developer and DB2®. In his 27 years with IBM, Norman has worked as an instructor and also in areas of hardware support, software support, marketing support, network support and now developer support.

**Michael Fiebig** is an Advisory IT Specialist and member of the IBM EMEA WebSphere Support Organization, which is based in Switzerland. He has over 22 years of experience in working with S/34, S/36, S/38, and the System i platform. His areas of expertise include i5/OS, ERP solutions, and WebSphere products.

**Rafal Jablonski** is an Advisory IT Specialist in Poland and the CEMAAS region. He has been with IBM since April 2003. Prior to joining IBM, Rafal had seven years of experience in application development and integration. He started his career as an Application Developer and has worked with a wide range of development languages and tools. His areas of expertise include OS/400®, i5/OS, Java™ 2 Platform, Enterprise Edition (J2EE™), C and C++, WebSphere Application Server, and MQSeries®. Rafal has a master degree in electrical engineering from AGH University of Science and Technology in Krakow.

**Heather R. Jones** is a Staff Software Engineer working at the IBM Rochester, Minnesota location. She earned a BS in Scientific and Technical Communications from Michigan Technological University. She has iSeries system operator certification from Alexandria Technical College. For the past six years, she has worked as a technical writer in the User Technologies area, covering multiple i5/OS documentation projects, which includes integrated file system, DB2 UDB for iSeries, and WebSphere Application Server for i5/OS. Currently, she is the documentation team leader for the WebSphere Application Server for i5/OS product, working on maintaining the Information Center for all versions of the product.

**Adam Smye-Rumsby** joined IBM in 2000. He currently works as an Advisory Software Support Specialist for IBM in the UK, where he solves customer problems that are related to IBM WebSphere Portal and Lotus® Domino®. Previously he worked at IBM Hursley Laboratory in the UK testing IBM Java software development kits (SDKs) on a variety of platforms. He also worked as a tester on IBM Web Services technology. Adam has a Computer Science degree from the University of Portsmouth.

Thanks to the following people for their contributions to this project:

Linda Robinson  
Jenifer Servais  
International Technical Support Organization, Rochester Center

Melissa Anderson  
John Attinella  
Mike Burke  
Arvin J. Fisher  
Pat Fleming  
Kevin Hubbard  
David Legler  
Scott Moore  
Scott M Nelson  
Kevin Paterson  
Lynda Ramier  
Tim Rowe  
Dick Salz  
Frances Stewart  
Blair Wyman  
Joseph Zoght  
IBM Rochester, Minnesota

Rufus Credle  
Carla Sadtler  
IBM ITSO, Raleigh Center

Jose Juan Escudero  
Trentisa, Spain

Andy Hagger  
IBM Switzerland

## Become a published author

Join us for a two-to-six week residency program! Help write an IBM Redbook dealing with specific products or solutions, while getting hands-on experience with leading-edge technologies. You will have the opportunity to team with IBM technical professionals, Business Partners, and Clients.

Your efforts will help increase product acceptance and customer satisfaction. As a bonus, you will develop a network of contacts in IBM development labs and increase your productivity and marketability.

Find out more about the residency program, browse the residency index, and apply online at:

[ibm.com/redbooks/residencies.html](http://ibm.com/redbooks/residencies.html)

## Comments welcome

Your comments are important to us!

We want our Redbooks to be as helpful as possible. Send us your comments about this or other Redbooks in one of the following ways:

- ▶ Use the online **Contact us** review redbook form found at:

[ibm.com/redbooks](http://ibm.com/redbooks)

- ▶ Send your comments in an email to:

[redbooks@us.ibm.com](mailto:redbooks@us.ibm.com)

- ▶ Mail your comments to:

IBM Corporation, International Technical Support Organization  
Dept. HYTD Mail Station P099  
2455 South Road  
Poughkeepsie, NY 12601-5400





# System i platform and WebSphere Application Server

In this chapter, we provide an overview of how you can implement WebSphere Application Server on the i5/OS operating system. Whether you are new to WebSphere Application Server or you are migrating from a previous version, you can find useful information about the WebSphere Application Server Version 6.1 for i5/OS product, enhancements to the Version 6.1 for i5/OS product, and differences between Version 6.1 for i5/OS and Version 6.1 on other platforms (distributed platforms and z/OS®).

# 1.1 Overview of WebSphere Application Server Version 6.1 for i5/OS

WebSphere Application Server consists of the following components:

- ▶ *Runtime environment*, which is installed on i5/OS.
- ▶ *Administration tools*, which run on i5/OS or a workstation, such as Windows®.
- ▶ *Development tools*, which run on a workstation, such as Windows.

We explore each component in more details in the following sections.

## 1.1.1 Runtime environment

All editions of WebSphere Application Server Version 6.1 provide a J2EE-compliant environment that allows you to manage server-side Java components. These Java components can add complex business logic and dynamic functions to static HTML Web pages and to standalone Java application clients. Table 1-1 contains the Version 6.1 supported J2EE specifications.

Table 1-1 WebSphere Application Server V 6.1 for i5/OS supported specification levels

Specification	Specification level
J2EE	1.4
JDK™	Java Developer Kit V5.0 (5722-JV1 option 7) and IBM J2SE™ 32-bit V5 (5722-JV1 option 8)
Java Servlet	2.4
JavaServer™ Pages™ (JSP™)	2.0
Enterprise JavaBeans™ (EJB™)	2.1
EJB to CORBA Mapping	1.1
Web Services for J2EE	1.1
SOAP with Attachments API for Java	1.2
JDBC™	3.0
Java Connector Architecture (JCA)	1.5
Java Message Service (JMS)	1.1
JavaMail™ API	1.3
Java Authorization Contract for Containers	1.0
Java Naming and Directory Interface™ (JNDI)	1.2.1
Java Transaction API	1.0.1
Java Transaction Service	1.1
JavaBeans Activation Framework	1.0.2

## 1.1.2 Hardware and software requirements

In this section, we provide an overview of the minimum hardware and software that is required to install WebSphere Application Server Version 6.1 for i5/OS.

For detailed information about WebSphere Application Server Version 6.1 for i5/OS prerequisites, installation planning, and installation procedures, see Chapter 2, “Planning for WebSphere Application Server installation” on page 17 and Chapter 3, “Installing WebSphere Application Server” on page 31.

## Hardware requirements

Table 1-2 contains the minimum hardware requirements for WebSphere Application Server Version 6.1 for i5/OS. You might require more hardware resources if you are running concurrent profiles, have multiple users or installations, or require enhanced response times.

Table 1-2 Minimum hardware requirements to run WebSphere Application Server Version 6.1 for i5/OS

Resource	Minimum level	Additional information
Disk space	1240 MB	Required for installation
Minimum server models	<p>For servlet or JavaServer Pages (JSP) applications:</p> <ul style="list-style-type: none"> <li>▶ iSeries Model 270 with processor feature 2250</li> <li>▶ iSeries Model 820 with processor feature 2395</li> </ul> <p>For enterprise bean applications:</p> <ul style="list-style-type: none"> <li>▶ AS/400e™ server 170 with processor feature 2385 or</li> <li>▶ AS/400e server 720 with processor feature 2062 or</li> <li>▶ iSeries Model 270 with processor feature 2250 or</li> <li>▶ iSeries Model 820 with processor feature 2395</li> </ul>	
Processor CPW	<p>For servlet or JSP applications:</p> <ul style="list-style-type: none"> <li>▶ 300</li> </ul> <p>For enterprise Java bean applications:</p> <ul style="list-style-type: none"> <li>▶ 450</li> </ul>	
Memory	750 MB	This memory requirement is in addition to memory that is required for any other applications that are running on your i5/OS system.

## Software requirements

Table 1-3 shows the software that is required to run WebSphere Application Server Version 6.1 for i5/OS.

Table 1-3 Required software for WebSphere Application Server Version 6.1 for i5/OS

Required software	Additional information
<ul style="list-style-type: none"> <li>▶ i5/OS Version 5 Release 3 (V5R3), or</li> <li>▶ i5/OS Version 5 Release 4 (V5R4)</li> </ul>	The i5/OS must be in an unrestricted state, and your user profile must have *ALLOBJ and *SECADM special authorities.
<ul style="list-style-type: none"> <li>▶ IBM Developer Kit for Java Version 1.5 (5722-JV1 option 7), or</li> <li>▶ IBM J2SE 32-bit V5 (5722-JV1 option 8)</li> </ul>	Required to use WebSphere Application Server.

Required software	Additional information
i5/OS Qshell (5722-SS1 option 30)	Required to run installation scripts and to use other scripts in WebSphere Application Server.
i5/OS Host Servers (5722-SS1 option 12)	Required for installation.
Extended Base Directory Support (5722-SS1 option 3)	Required by the application server runtime if you run i5/OS V5R4.
Cryptographic Access Provider 128-bit for iSeries (5722-AC3)	Required by the application server runtime if you run i5/OS V5R3.
All necessary fixes	For a list of current fixes, see <a href="http://www.ibm.com/eserver/series/software/websphere/wsappserver/">http://www.ibm.com/eserver/series/software/websphere/wsappserver/</a> and click PTFs.

Table 1-4 shows software that is optional to run WebSphere Application Server Version 6.1 for i5/OS.

Table 1-4 Optional software for WebSphere Application Server Version 6.1 for i5/OS

Optional software	Additional information
HTTP server	Not required for installation, but recommended for production environments that use servlets and JSP files. If you plan to deploy only enterprise beans, you do not need an HTTP server instance. WebSphere Application Server supports these HTTP server products: <ul style="list-style-type: none"> <li>▶ IBM HTTP Server (powered by Apache) (5722-DG1)</li> <li>▶ Lotus Domino for iSeries 6.5 (5733-L65)</li> <li>▶ Lotus Domino for iSeries 7 (5733-LD7)</li> </ul>
i5/OS Digital Certificate Manager (5722-SS1 option 34)	Not required for installation, but required if you plan to use Secure Sockets Layer (SSL) protocol.
DB2 Query Manager and SQL Development Kit for iSeries (5722-ST1)	Can be helpful in developing client applications.

### 1.1.3 Administration tools

WebSphere Application Server Version 6.1 for i5/OS provides several administrative clients for deploying and administering your applications and application serving environment. The administrative clients that are most commonly used on i5/OS are the:

- ▶ Administrative console
- ▶ Qshell environment
- ▶ IBM Web Administration for i5/OS.

In addition to the mentioned administration tools, note that there are other advanced methods to perform administrative tasks in WebSphere Application Server.

#### WebSphere Application Server administrative console

The administrative console is a browser-based graphical administrative interface for configuring and managing WebSphere Application Server resources. You can use the administrative console to display and change your WebSphere Application Server configurations and to manage your WebSphere Application Server resources.

The Version 6.1 administrative console has simplified administration with simpler panels and more wizards. It was integrated into the Integrated Solutions Console, which provides a different look and feel. The updated Version 6.1 administrative console has new features that allow you to customize your layout. You can create a “My Tasks” page that allows you to create and edit a list of the user-selected tasks to view in the console navigation.

For more information about updates and customizing the Version 6.1 administrative console, see the following topic in the WebSphere Application Server Version 6.1 for i5/OS Information Center:

[http://publib.boulder.ibm.com/infocenter/wasinfo/v6r1/index.jsp?topic=/com.ibm.webSphere.nd.iseries.doc/info/iseriend/ae/tcon\\_console.html](http://publib.boulder.ibm.com/infocenter/wasinfo/v6r1/index.jsp?topic=/com.ibm.webSphere.nd.iseries.doc/info/iseriend/ae/tcon_console.html)

For more information about typical daily tasks that you can perform using the administrative console, see Chapter 4, “Day-to-day operations” on page 85.

## The Qshell environment

Qshell is a UNIX®-like environment that is available on i5/OS.

WebSphere Application Server provides several scripts that you can use to administer application servers, profiles, nodes, and cells. All of the WebSphere Application Server scripts are located in the bin directory of your installed product. By default, these locations are as follows:

- ▶ WebSphere Application Server - Express:  
/QIBM/ProdData/WebSphere/AppServer/V61/Express/bin
- ▶ WebSphere Application Server - Base:  
/QIBM/ProdData/WebSphere/AppServer/V61/Base/bin
- ▶ WebSphere Application Server Network Deployment:  
/QIBM/ProdData/WebSphere/AppServer/V61/ND/bin

In addition, there is a proxy version of each script that resides in your profile’s bin directory. If you invoke a script from the bin directory of your profile, you do not need to specify the `-profileName` parameter.

There are several ways to run QShell commands to ensure that you use (from the correct directory) the correct version. The WebSphere Application Server Base edition is used for these examples.

- ▶ Invoke the fully qualified path name of the script, where `script_name` is the name of the script and `parameters` represents the parameters that are passed to the script:  
/QIBM/ProdData/WebSphere/AppServer/V61/Base/bin/*script\_name parameters*
- ▶ Invoke the script from the CL command line or from an i5/OS CL program, where `script_name` is the name of the script, and `parameters` represents the parameters that are passed to the script. To use this method, run the STRQSH command, and specify the fully qualified path name of the script:

```
STRQSH CMD(' /QIBM/ProdData/WebSphere/AppServer/V61/Base/bin/script_name  
parameters')
```

- ▶ Use the `cd` command to change to the bin directory:

```
cd /QIBM/ProdData/WebSphere/AppServer/V61/Base/bin
```

Then run the script:

```
script_name parameters
```

In the script:

- *script\_name* is the name of the script.
  - *parameters* represents the parameters that are passed to the script.
- ▶ You can also update the PATH environment variable to automatically locate the script when you run it. After you update the PATH variable, you can run these scripts from any directory. To update the PATH environment variable, follow these steps:
    - a. Edit the `.profile` file in the `/home/user_profile_name` directory, where *user\_profile\_name* is the name of your i5/OS user profile.

**Note:** If the `.profile` file does not exist, create it in this directory. You can use the EDTF command from the CL command line or use any editor from a workstation. Also note that `.profile` is the full name of the file. When you start Qshell, it searches for the `.profile` file, and runs the commands listed in it. You can use the `.profile` file to set persistent environment variables for your Qshell session.

- b. Add a line similar to the following one for the Base edition to the `.profile` file:

```
export PATH=/QIBM/ProdData/WebSphere/AppServer/V61/Base/bin:$PATH
```

Make sure you point to the correct directory for your installation.

- c. Save the file.

For more information about Qshell, including how to perform daily operational tasks, see Chapter 4, “Day-to-day operations” on page 85.

## IBM Web Administration for i5/OS

The IBM Web Administration for i5/OS interface combines forms, tools, and wizards to create a simplified environment to set up and manage your application server that runs on your i5/OS.

IBM Web Administration for i5/OS is rich in function, examples, error-checking, and ease-of-use. Administration is made significantly easier through the use of forms, wizards, tasks, and tools, instead of using multiple Qshell scripts or the WebSphere Application Server administrative console.

IBM Web Administration for i5/OS has forms and wizards for managing WebSphere Application Server and WebSphere Portal servers that are currently configured on your i5/OS. You can also view server properties forms, the WebSphere Application Server administrative console, and problem determination logs through this interface.

**Note:** Be aware that there are some limitations to managing your application server environment using IBM Web Administration for i5/OS that include managing profiles with administrative security enabled, managing deployment managers, or managing federated nodes.

For more information about how to use IBM Web Administration for i5/OS with WebSphere Application Server, including how to start the interface and perform daily operational tasks, see Chapter 4, “Day-to-day operations” on page 85.

For detailed information about IBM Web Administration for i5/OS, visit the following Web site, which is in the i5/OS V5R4 Information Center:

<http://publib.boulder.ibm.com/infocenter/iseriess/v5r4/index.jsp?topic=/rzaie/rzaieconadmin.htm>

## 1.1.4 Development tools

There are three main development tools that you can use with WebSphere Application Server Version 6.1 for i5/OS:

- ▶ Rational Application Developer (RAD)
- ▶ WebSphere Development Studio Client for iSeries
- ▶ The WebSphere Application Server Toolkit.

### Rational Application Developer

Rational Application Developer helps you to design, develop, analyze, test, profile, and deploy Web, Service-oriented Architecture (SOA), Java, J2EE and portal applications. You can launch the Rational Web Developer installation from the Launch Pad application.

RAD includes full support for the J2EE programming model, integrated portal development features, Unified Modeling Language (UML) visual editing capabilities, code analysis functions, and automated test and deployment tools. RAD is optimized for IBM WebSphere software and provides capabilities for deploying to other runtime platforms as well.

For more information about the functionality of Rational Application Developer with WebSphere Application Server, see:

<http://www-306.ibm.com/software/awdtools/developer/application/index.html>

### WebSphere Development Studio Client for iSeries

WebSphere Development Studio Client for iSeries V7.0 inherits and extends the robust, easy-to-use Rational Software Delivery Platform (RSDP) and a subset of Rational Application Developer for WebSphere Software V7.0, to deliver an integrated development environment (IDE). It also has tools for developing Web, Web services, client/server, and i5/OS server applications using programming languages, such as RPG, COBOL, CL, and Java.

WebSphere Development Studio Client Advanced Edition for iSeries V7.0 contains all of the development tools that are included in WebSphere Development Studio Client, plus it inherits and builds on additional premium Web, Enterprise Java Bean (EJB), and J2EE development capabilities from IBM Rational Application Developer V7.0. It also provides specific advanced System i tools, which includes Navigation support, Rational ClearCase® integration, and an Eclipse-based Screen designer technology preview.

For more information about WebSphere Development Studio Client for iSeries, see the Information Center at:

<http://publib.boulder.ibm.com/infocenter/iadthelp/v7r0/index.jsp>

### WebSphere Application Server Toolkit

The WebSphere Application Server Toolkit (AST) helps you to create, test and deploy applications using WebSphere Application Server Version 6.1 for i5/OS. All of the tools are integrated into a workbench to simplify the development process, but you can also use command-line tools. Wizards for creating Java, J2EE, enterprise bean, and portlet applications help you to get started by creating projects with a basic set of files. Editors provide code assist and validation. Integrating with WebSphere Application Server enables you to test and deploy applications from the workbench.

Compared to the previous releases of AST, the toolkit has a full application development environment. For more information about what is new with AST in Version 6.1, visit the following Web address in the WebSphere Application Server Version 6.1 Information Center:

<http://publib.boulder.ibm.com/infocenter/wasinfo/v6r1/index.jsp?topic=/com.ibm.welcome.ast.doc/topics/astnew.html>

## 1.1.5 Platform differences

WebSphere Application Server Version 6.1 for i5/OS has several features that differentiate it from other platforms.

### Packaging differences

- ▶ WebSphere Application Server - Express is shipped free of charge with i5/OS V5R3 and V5R4.
- ▶ No Java Development Kit (JDK) is shipped with WebSphere Application Server Version 6.1 for i5/OS. To install WebSphere Application Server, you must use the IBM Developer Kit for Java Version 1.5, which is shipped with i5/OS.

**Restriction:** You cannot use IBM Technology for Java VM (5722-JV1, opt.8) to install the WebSphere Application Server 6.1 product. However, the update installer, which installs fix packs, uses the IBM Technology for Java VM, if it is installed.

- ▶ After you install WebSphere Application Server Version 6.1, both the IBM Developer Kit for Java Version 1.5 and IBM J2SE 32-bit V5 are supported for running WebSphere Application Server Version 6.1. See 9.1.6, “Choosing a JVM to use for best performance” on page 293 for more information about both options.

### Installation differences

- ▶ Multiple installations of Version 6.1 on the same system or partition are allowed, which is a change from previous releases of WebSphere Application Server.
- ▶ All Version 6.1 products can coexist with previous releases.
- ▶ By default, the samples gallery is not installed.
- ▶ During installation of WebSphere Application Server Network Deployment, a cell profile is created by default that consists of two profiles: dmgr and default. The dmgr profile is created during installation. The default profile is already federated to the cell that is managed by the dmgr profile. The default profile consists of a single application server (server1), which has the default application and the sample applications installed (if you selected to install the samples gallery during installation).
- ▶ There is no automatic port resolution during installation.

### Administration differences

- ▶ All scripts that are shipped with WebSphere Application Server are run in the Qshell environment.
- ▶ There are several i5/OS-only scripts:
  - checkprereqs
  - chgwassvr
  - configureOS400WebServerDefinition
  - dspwasinst
  - enbprfwas

- grtwasaut
- rvkwasaut
- removeOS400WebServerDefinition
- servicetools
- portconflict
- updwashost
- iptest
- queryWASInstalls

### **Application development environment differences**

- ▶ The supported Web servers on i5/OS are:
  - IBM HTTP Server, powered by Apache (2.0.49) for iSeries
  - Lotus Domino for iSeries (Versions 6.5 and 7)
  - any supported Web server on other platforms

IBM HTTP Server is shipped with i5/OS.
- ▶ An i5/OS-specific tool called JSP Pretouch controls JavaServer Pages (JSP) compilation and classloading. The tool allows you to chose to compile JSPs at application server startup as opposed to the first time it is accessed in an application server environment.

## **1.2 WebSphere Application Server Version 6.1 for i5/OS enhancements**

WebSphere Application Server Version 6.1 for i5/OS offers several marked improvements over previous releases:

- ▶ Product co-existence
 

The majority of WebSphere Application Server versions and editions can coexist on the same i5/OS, as long as the product is supported on that version of i5/OS, which allows for easier migration and upgrade between versions and editions.
- ▶ J2EE-compliance of Express
 

Starting at Version 6, WebSphere Application Server - Express edition is fully J2EE-compliant.
- ▶ Installation enhancements
 

There are several improvements and enhancements to the installation process that we want to make you aware of. See 1.2.1, “Installation enhancements” on page 10 for details about specific areas of improvement.
- ▶ In WebSphere Application Server V6.1, you can now change the installation root at install time. See 1.2.2, “Default installation root changes” on page 12 for more information.
- ▶ New subsystem for WebSphere Application Server processes
 

All editions of WebSphere Application Server V6.1 for i5/OS use the QWAS61 subsystem. The subsystem description for QWAS61 is located in the product library, QWAS61. By default, the application server, node agent, and deployment manager processes run in this subsystem.
- ▶ Administration enhancements: see 1.2.3, “Administration enhancements” on page 13 for details.
- ▶ Application development enhancements: see 1.2.4, “Application development enhancements” on page 13 for details.

- ▶ Application Server Toolkit (AST) enhancements: see 1.2.5, “Application Server Toolkit (AST) enhancements” on page 14 for details.
- ▶ Performance and tuning enhancements: see 1.2.6, “Performance and tuning enhancements” on page 14 for details.
- ▶ Security enhancements: see 1.2.7, “Security enhancements” on page 15 for details.
- ▶ Deprecated and removed features
 

The `crtwasinst`, `1stwasinst`, `dltwasinst` and `wasprofile` Qshell scripts were deprecated at V6 or V6.1. Instead, use the `manageProfiles` script.

For a complete list of all features deprecated or removed in V6.1 and prior releases, see: [http://publib.boulder.ibm.com/infocenter/wasinfo/v6r1/index.jsp?topic=/com.ibm.websphere.base.iseries.doc/info/iseres/ae/rmig\\_deprecationlist.html](http://publib.boulder.ibm.com/infocenter/wasinfo/v6r1/index.jsp?topic=/com.ibm.websphere.base.iseries.doc/info/iseres/ae/rmig_deprecationlist.html)

## 1.2.1 Installation enhancements

There are several changes in the installation process that we want to highlight.

- ▶ You can now install WebSphere Application Server Version 6.1 for i5/OS using CD or DVD media.
- ▶ Security is now enabled by default at installation time. For a silent or graphical installation to succeed, you must either provide a user ID and password or disable security.
- ▶ A launchpad is now available when you install remotely onto an i5/OS from a Windows workstation. The launchpad does not run locally on an i5/OS.
- ▶ Installation routines exist for the following components: WebSphere Application Server Version 6.1 products, Web server plug-ins, and application clients. Separate installation procedures let you install only what you need on a particular partition. The Web server plug-ins are still included with the application server product. If you are running your application server and Web server on the same i5/OS, you do not need to separately install the Web server plug-ins.
- ▶ A new tool, the *Installation Factory*, creates a customized, distributable installation image that is tailored to your specific needs. Now, while in connected mode, you can create the installation packages on one system and clone them to another systems.
- ▶ The standard InstallShield MutliPlatform (ISMP) option format (-W option=value and -P option=value) is replaced with an -OPT option that takes sub-options whose names are simpler, more meaningful, and less subject to change, from one release to another. The same options are used in the command line invocation of the wizard and in the silent installation parameters in the response files.
- ▶ Removing and reinstalling application server environments is simplified. Uninstalling an application server profile does not change the shared system files of the product. Now you can leave profile directories installed when you uninstall the product and its core product files.

- ▶ WebSphere Application Server Version 6.1 no longer uses MQ Series to support the embedded JMS function contained in the application server. You can use either a separate WebSphere MQ license or the new service integration bus architecture for messaging services. If you set up the integrated JMS that was previously under Version 5 or Version 5.1, you can continue to use any JMS servers on nodes that have not yet migrated to Version 6.1.

- ▶ Multiple Installations to the same partition are now possible

The main difference between WebSphere Application Server V6.1 installation and past releases is that you can install more than one complete product installation in the same machine partition.

This new feature enables you to have multiple WebSphere Application Server environments in a single partition and also permits coexistence between the Base and Express editions (not possible in version 6.0 because they share the same directory structure).

**Tip:** Now you can install one WebSphere Application Server fix pack in your server in a test environment without any risk for your production applications. For more information see 3.6.2, “Installing the Update Installer” on page 54.

You can now choose to install WebSphere Application Server binaries and profiles in a different location other than the default location. The default install locations are (Product data / Profiles location):

- For WebSphere Application Server Express installations:

```
/QIBM/ProdData/WebSphere/AppServer/V61/Express
/QIBM/UserData/WebSphere/AppServer/V61/Express/profiles
```

- For WebSphere Application Server (Base) installations:

```
/QIBM/ProdData/WebSphere/AppServer/V61/Base/
/QIBM/UserData/WebSphere/AppServer/V61/Base/profiles/
```

- For WebSphere Application Server Network Deployment installations:

```
/QIBM/ProdData/WebSphere/AppServer/V61/ND/
/QIBM/UserData/WebSphere/AppServer/V61/ND/profiles/
```

See 3.4.1, “Remote GUI installation” on page 38 for more information about installation directories.

**Important:** You must specify one unique install location (ProdData) and profile location (UserData) for each installation.

- ▶ Multiple Installations Libraries

WebSphere Application Server installation creates two libraries:

- The first one is shared by all WAS installations, which is the *Shared Product Library*:

QWAS61

This Shared product library contains the following native i5/OS objects, which all installations share:

- Product definition
- Product loads for installed products (for example, WebSphere Application Server Network Deployment 5733W61 option 3)
- Subsystem description QWAS61

- Job description QWASJOB
  - Job queue: QWASJOBQ
  - Job Class: QWASCLS
  - Message file: QWAS61MSGF
- The second library is your specific installation library, which is the *Install Product Library*. The system determines the name of the Install Library using this convention:

QWAS61x

In QWAS61, x is substituted for 'A', 'B', 'C' and so on. If you have more than 26 installations, then the installer starts using a two-letter suffix.

The install product library is needed to maintain different fix pack levels between the different installations because each fix pack can modify some \*SRVPGM and other i5/OS objects.

- ▶ Where to find information about multiple installations

The `product.properties` file provides information about the install product library and default profile location for each installation. It is located under:

`<install_root>/properties/product.properties`

To get a list of all your installed environments, including default profile location and install library, you can use the following script:

`/QIBM/WAS/bin/querywasinstalls`

The information used by `querywasinstalls` is stored in this xml file:

`/QIBM/WAS/.ibm/.nif/.nifregistry`

**Attention:** Although you can install more than one WebSphere Application Server environment on the same partition, you can only create one installation at a time. Starting a second installation while one is still running results in the second install failing. For that reason, install and configure each WebSphere Application Server environment sequentially.

- ▶ Administrative security can be enabled at install time

Another difference from the previous version is that you can now turn on Administrative Security at install time. The GUI installation presents a window where you can choose to activate Administrative Security or not, as shown in Figure 3-11 on page 44.

In silent installations, the response file has new options for Administrative Security activation. See 3.4.2, "Silent installation" on page 48 for more information.

For detailed information about WebSphere Application Server Version 6.1 for i5/OS prerequisites, installation planning, and installation procedures, see Chapter 2, "Planning for WebSphere Application Server installation" on page 17 and Chapter 3, "Installing WebSphere Application Server" on page 31.

## 1.2.2 Default installation root changes

Previous versions of WebSphere Application Server for i5/OS did not allow you to select the default installation or user data root during the installation process. The default installation root was in the `/QIBM/ProdData/` directory path, and the default user data root was in the `/QIBM/UserData/` directory path.

In Version 6.1, profiles are still created under the ProdData and UserData root directory path by default, but you can now specify a different path when you install WebSphere Application Server Version 6.1 for i5/OS.

We recommend that you still use the default ProdData and UserData directory paths during installation, unless it does not make sense for your environment.

There are several scripts you can run to display information about the WebSphere Application Server products that are installed on your system. The `querywasinstalls` Qshell script and the `installRegistryUtils` Qshell script are located in the /QIBM/WAS/bin directory. These two scripts can assist you in locating your install root and user data root if you do not select the default directory paths during installation.

For detailed information about WebSphere Application Server Version 6.1 for i5/OS prerequisites, installation planning, and installation procedures, see Chapter 2, “Planning for WebSphere Application Server installation” on page 17 and Chapter 3, “Installing WebSphere Application Server” on page 31.

### 1.2.3 Administration enhancements

There are many changes in the administration of WebSphere Application Server V6.1. In this section, we provide some of the ones that are highlighted for the release. For detailed information about all of the new administration changes for the release, visit the following Web site, which is in the WebSphere Application Server Version 6.1 for i5/OS Information Center:

[http://publib.boulder.ibm.com/InfoCenter/wasinfo/v6r1/topic/com.ibm.websphere.base.iseries.doc/info/iseres/ae/welc\\_newadministrator.html](http://publib.boulder.ibm.com/InfoCenter/wasinfo/v6r1/topic/com.ibm.websphere.base.iseries.doc/info/iseres/ae/welc_newadministrator.html)

WebSphere Application Server, Version 6.1 highlights include:

- ▶ Console command assistant.  
Using command assistance, you can view wsadmin scripting commands in the Jython language for the last action run in the administrative console.
- ▶ Integrated development environment for scripted administration in Application Server Toolkit.  
Command assistance in the administrative console maps your administrative activities to wsadmin scripting commands, so that you can capture your console knowledge and apply it to wsadmin. Using command assistance, you can view wsadmin scripting commands in the Jython language for the last action run in the administrative console. For more information see Chapter 7, “Using WebSphere administrative (wsadmin) scripting” on page 217.
- ▶ Debugging enhancements in IBM Java 5 SDK.
- ▶ IBM Support Assistant bundled for self-help (see Appendix C, “IBM Support Assistant” on page 421).
- ▶ Simplified administration with simpler panels and more wizards.
- ▶ Stand-alone thin administrative client that comes with WebSphere Application Client.

### 1.2.4 Application development enhancements

New in Version 6.1 is support for the JSR 168 Portlet programming model, the JSR 116 Session Initiation Protocol (SIP) Servlets specification, and the JavaServer Faces (JSF) Widget Library, supported through JSF 1.1.

The Portlet programming model is supported through wizards to create portlet projects and portlets, an editor to manage the portlet deployment descriptor (portlet.xml), and the ability to import a portlet .war file.

WebSphere Application Server Version 6.1 for i5/OS includes JSR 116 SIP Servlets that are built in a converged servlet container. Servlets can share a single application session across protocols. HTTP Servlets and Portlets can create SIP messages and tie state together with a single application. SIP tooling is also included.

The JSF Widget Library is a set of functions that are pre-built for reuse within JSFs. It integrates widgets from a number of sources. It includes the JSF components from Rational Web Developer (RWD), with the exception of the base JSF components, which are already included in the Application Server runtime.

## 1.2.5 Application Server Toolkit (AST) enhancements

In previous versions of WebSphere Application Server, you deployed an application and set up its required configuration in two separate steps. In Version 6.1, the WebSphere Application Server Toolkit (AST) enables you to define the required configuration (such as a data source) as a part of the application. At deployment, you can choose to process the embedded configuration data, which automatically sets up the required configuration for the application.

In Version 6, AST used the Eclipse Update Manager to retrieve and apply maintenance. In Version 6.1, it uses the Rational Product Updater (RPU), which is built on top of the Update Manager. RPU can update the JRE™ that is bundled with AST, whereas Update Manager only updated Eclipse plug-ins. RPU runs as a separate process from the code it updates, whereas Update Manager runs within AST itself.

## 1.2.6 Performance and tuning enhancements

There are several enhancements to WebSphere Application Server performance and tuning that we want to highlight:

- ▶ Improved performance is achieved with IBM Developer Kit for Java Version 1.5 because of new JVM™ enhancements, new memory allocation and garbage collection schemes, and reduced lock contention for improved ORB scalability.
- ▶ Improved performance is achieved through various improvements in the Web Container, Enterprise JavaBeans (EJB), Dynamic Fragment Cache, and Web services areas.
- ▶ In-process messaging has code path improvements, along with a switch to use file system as a message store along with the relational database.
- ▶ Startup time and the memory footprint improved with IBM Developer Kit for Java Version 1.5 because classes are shared across JVMs, and the class cache is in shared memory for faster startup time.
- ▶ Performance Monitoring Infrastructure (PMI) is enabled during installation.

For more information about performance and tuning with WebSphere Application Server Version 6.1 for i5/OS, see Chapter 9, “Performance monitoring and tuning” on page 289.

## 1.2.7 Security enhancements

There are several enhancements to WebSphere Application Server security that we want to highlight:

- ▶ By default, you can enable administrative security during installation. You can also enable administrative security when you create a profile with the manageProfiles Qshell script.
- ▶ Server IDs are automatically generated.
- ▶ WebSphere key and certificate management was simplified.
- ▶ You can now federate various repositories, so that you can manage them as one entity.
- ▶ The Simple and Protected GSS-API Negotiation Mechanism (SPNEGO) protocol is now supported, which allows flowing Kerberos tokens from Web browsers, such as FireFox, Mozilla, or Internet Explorer®.
- ▶ The WS-I Basic Security Profile 1.0 is now supported to improve interoperability with other vendors.
- ▶ You can now perform Web authentication with or without Web authorization. A Web client's authenticated identity is available whether or not Web authorization is required. There is enhanced control over Web authentication behavior.
- ▶ Portlets are now treated similar to servlets, and you can enable direct access to portlet URLs (just like servlets).
- ▶ More administrative roles are defined to provide degrees of authority that are needed to perform certain administrative functions.
- ▶ You can grant administrative access to each user per resource instance.
- ▶ There is now hardware cryptographic device support for Web services security, which you can use to accelerate the cryptographic operations. Cryptographic keys can be stored on the hardware cryptographic device and never leave the device.

For more information about security in Version 6.1, see Chapter 8, "Turning on security" on page 241.





# Planning for WebSphere Application Server installation

In this chapter, we describe different scenarios for a WebSphere Application Server implementation. Before you install WebSphere Application Server, you have to choose the WebSphere edition and allocate adequate hardware resources.

In this planning section, we provide practical information about how to prepare your environment, which includes server sizing, for a successful WebSphere Application Server installation.

## 2.1 Choosing a WebSphere Application Server edition

The WebSphere Application Server V6.1 for i5/OS product family consists of multiple editions, each with different levels of functionality and complexity. Therefore, prior to installing the product, you must determine and decide which WebSphere Application Server functionality is required by your company's applications.

There are three editions available for WebSphere Application Server V6.1 for i5/OS: Express, Base, and Network Deployment.

Starting from V6.0, the functionality that is available in the Express and Base editions are the same. The advantage of using Express is that it is shipped as a licensed program product (LPP) with i5/OS V5R3M0, V5R3M5, and V5R4M0 at no additional charge.

The Express Edition is a good starting point to introduce yourself to WebSphere Application Server. It is the perfect environment for running WebFaced and non-critical applications.

If you are looking for high availability and scalability, then you need WebSphere Application Server Network Deployment. This edition adds high availability features, load balancing, advanced Web services support and extended management capabilities.

## 2.2 System i model recommendations

In this section, we give you some guidelines to help you choose a suitable System i server for your WebSphere Application Server environment.

**Note:** The configurations that we recommend in this section are based on the experience of the team that wrote this book. See Chapter 3, "Installing WebSphere Application Server" on page 31 for the official IBM minimum configuration for WebSphere Application Server V6.1

### 2.2.1 Processor recommendations

Your System i platform can run a lot of different workloads. Remember that WebSphere software is not going to be the only software running in your system.

WebSphere workloads are quite different from traditional loads because they are more resource-intensive. Choose faster processors up front instead of adding more of them, if you plan to run a WebSphere Application Server environment. On the System i platform, we usually talk about commercial processing workload (CPW) as the primary measure of processing capability; however, for Java-based loads, such as WebSphere Application Server, you must also consider the clock speed rating of the processor, which is measured in GHz. Generally the higher the clock speed, the more capable the processor.

To choose faster processors, we recommend that you choose the latest family of System i servers available. Also, choose processors with a Level 2 (L2) cache because they further improve performance.

### 2.2.2 Memory recommendations

Sufficient memory is very important for running WebSphere Application Server. Java and WebSphere workloads have significantly larger memory requirements than traditional

applications. Allocating enough memory is one of the most important steps in getting a good performance for your WebSphere applications. See Chapter 9, “Performance monitoring and tuning” on page 289 for instructions on calculating the amount of memory you need for the WebSphere workload.

We recommend that you use Collection Services, as we show in Figure 2-1, to obtain your current memory use without WebSphere Application Server installed. For a single server scenario, add 2 GB to your current machine memory requirements, which is a good starting point.

You can find more information about the Performance Data Collector (PDC) tool in the Information Center:

- ▶ For V5R3M0:

<http://publib.boulder.ibm.com/infocenter/iseriess/v5r3/index.jsp?topic=/rzaha/pdc.htm>

- ▶ For V5R4M0:

<http://publib.boulder.ibm.com/infocenter/iseriess/v5r4/index.jsp?topic=/rzaha/pdc.htm>

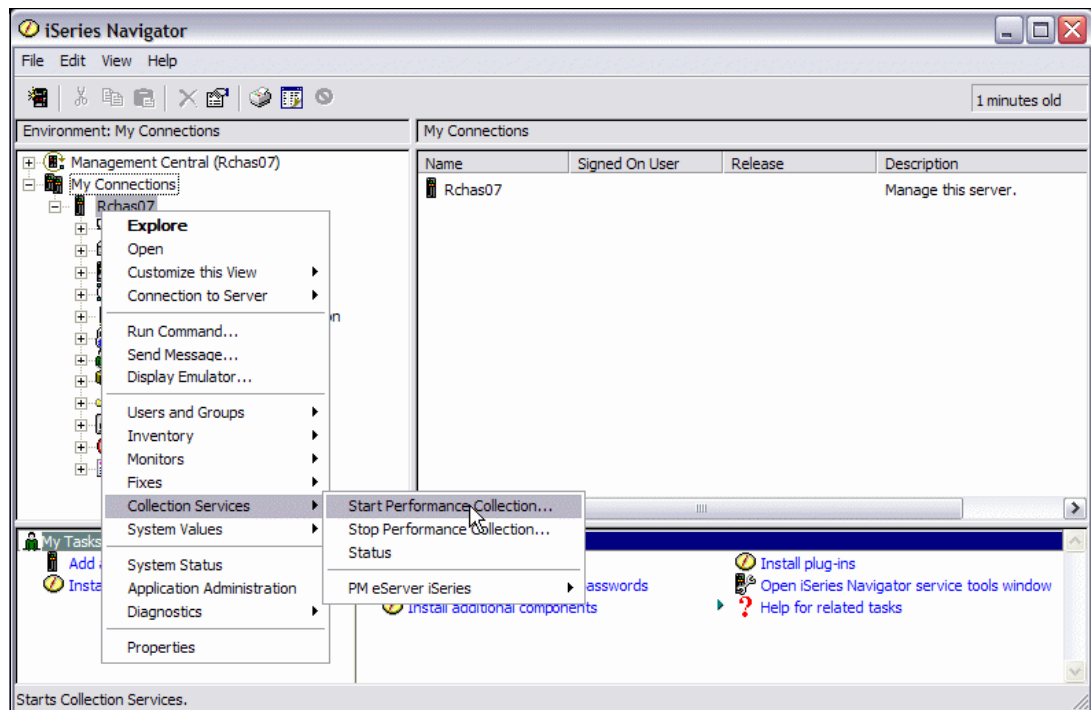

Figure 2-1 Use Collection Tools to determine existing resource usage before installing WebSphere Application Server

### 2.2.3 Storage requirements

There are now a lot of possibilities for configuring the storage for your system, both internal and external. External storage gives you scope to configure advanced features, for example, site replication for failover and disaster recovery purposes.

We recommend that you ensure that enough arms are present for sharing load between all of the installed hard drives. Also, consider the cache size of the disk controller because a bigger cache improves disk I/O performance.

## 2.2.4 Communications requirements

The communications hardware of your System i server is also important. Use Fiber or Copper Gb Ethernet cards instead of 10/100 Mb hardware.

Remember that it is not enough to change your Ethernet cards without also considering the rest of your network infrastructure. If you attach a Gigabit Ethernet card to a 10/100Mb switch, the connection speed is limited by your switch (less than 100 Mb).

## 2.3 Sizing your system with IBM Workload Estimator

To properly size your server for WebSphere Application Server, you can make use of the IBM Systems Workload Estimator (also referred to as the Estimator or WLE). The IBM Systems Workload Estimator is a Web-based sizing tool for System i, System p™, and System x™. You can use this tool to size a new system, to size an upgrade to an existing system, or to size a consolidation of several systems. The Estimator allows measurement input (from PMI data) to best reflect your current workload and provides a variety of built-in workloads to reflect your emerging application requirements. The Estimator provides current and growth recommendations for processor, memory, and disk that satisfy your overall performance requirements.

The Estimator recommends the system model, including processor, memory, and DASD requirements that are necessary to handle the overall workload with reasonable performance expectations. In the case of System i, the Estimator may also recommend the 5250 OLTP feature or the Accelerator feature. To use the Estimator, you select one or more workloads and answer a few questions about each workload. Based on the answers, the Estimator generates a recommendation and shows the predicted CPU utilization of the recommended system in graphical format. You can view, print, or generate the results in Portable Document Format (PDF).

You can access the IBM Systems Workload Estimator at the following Web site:

<http://www-912.ibm.com/wle/EstimatorServlet>

Alternately, you can download the offline version from the following location and install it on your workstation:

<ftp://ftp.software.ibm.com/as400/marketing/estimator/estimator.zip>

When sizing for i5/OS V5R4, WLE lets you choose the Java Virtual Machine for WebSphere Application Server V6.1, as shown in Figure 2-2 on page 21. The resulting estimates show somewhat lower CPW requirements for IBM Technology for Java VM and a significant reduction in the memory requirements. However, WebSphere Application Server V6.1 running on IBM Technology for Java VM has a maximum heap size of about 2.5 GB (due to IBM Technology for Java VM being a 32-bit application). WLE falls back to recommending the Classic JVM if it thinks the workload requires more than 3 GB of memory, and WLE generates a warning if it looks close.

Figure 2-2 shows how you can choose the JVM for WebSphere Application Server V6.1.

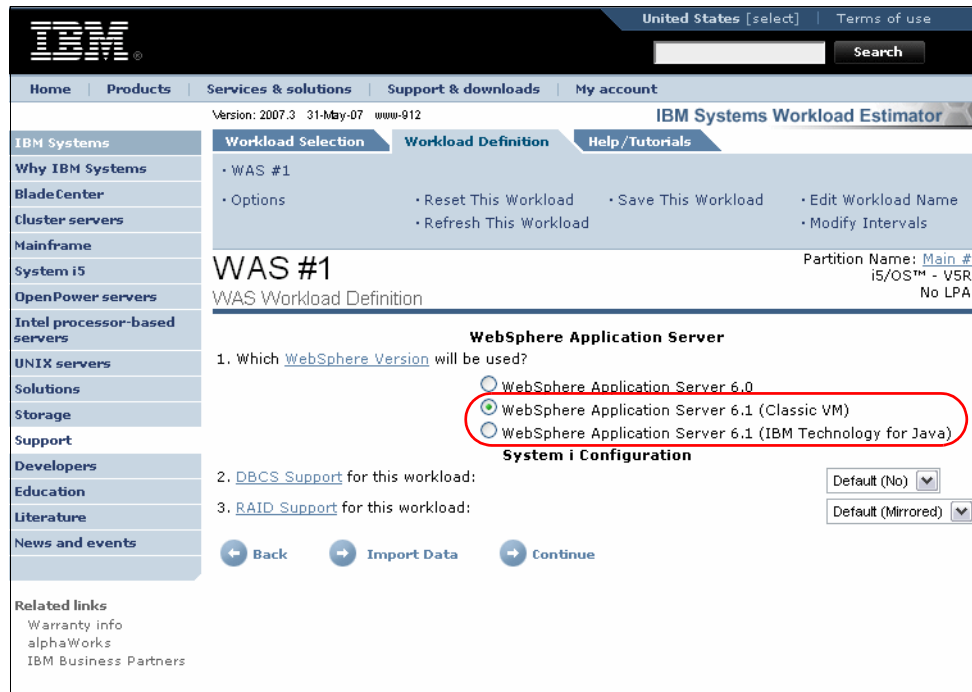

Figure 2-2 New features in Workload Estimator

The complexity of the applications you plan to run on WebSphere Application Server V6.1 is an important consideration when you choose a System i server. Sometimes it is not easy to accurately complete all of the information the Workload Estimator asks for. If possible, ask the development team members about previous experience in running the applications you are planning to install, and do not hesitate to ask them about the values you are supplying to Workload Estimator.

**Attention:** Remember to add all workloads that the system will run, not just the WebSphere Application Server workloads. You can add the existing workload of your system by adding an existing workload to Workload Estimator parameters or by importing data from Performance Monitor.

## 2.4 Topologies for WebSphere Application Server

There are several common configurations for WebSphere Application Server called *topology*. You can define a WebSphere Application Server topology as the set of components in your WebSphere Application Server environment and the relationship between them.

If you are interested in more advanced discussions about topologies, read the IBM Redbooks publication, *WebSphere Application Server V6.1: Planning and Design*, SG24-7305.

The main components of a WebSphere Application Server topology are:

- ▶ Application Server

Your WebSphere Application Server. The platform where your J2EE applications run.

- ▶ **Database Server**  
Where the data resides. In almost all i5/OS scenarios, the data is stored in DB2 Universal Database™ for i5/OS, but you can also use Cloudscape® or MySQL with i5/OS, or an external database server.
- ▶ **Web server**  
Although you can connect directly to your WebSphere Application Server instance's internal Web server from your browser, we recommend that you use an external Web server in your production environment. The Web server services requests for static data (for example, HTML pages and image files) and through the HTTP Plug-in serves the dynamic content of your application. The Web server is the front end of your topology.
- ▶ **HTTP server plug-in**  
This component is used to connect your Web server to your application server. See Chapter 5, "Working with HTTP servers in WebSphere Application Server environment" on page 163 for information about the HTTP server plug-in.

### 2.4.1 Basic standalone topology

The most basic WebSphere Application Server implementation is where all components of the topology are placed in the same system or partition, as shown in Figure 2-3. This topology fits intranet environments well, where there is no need for a high level of security because the network is private.

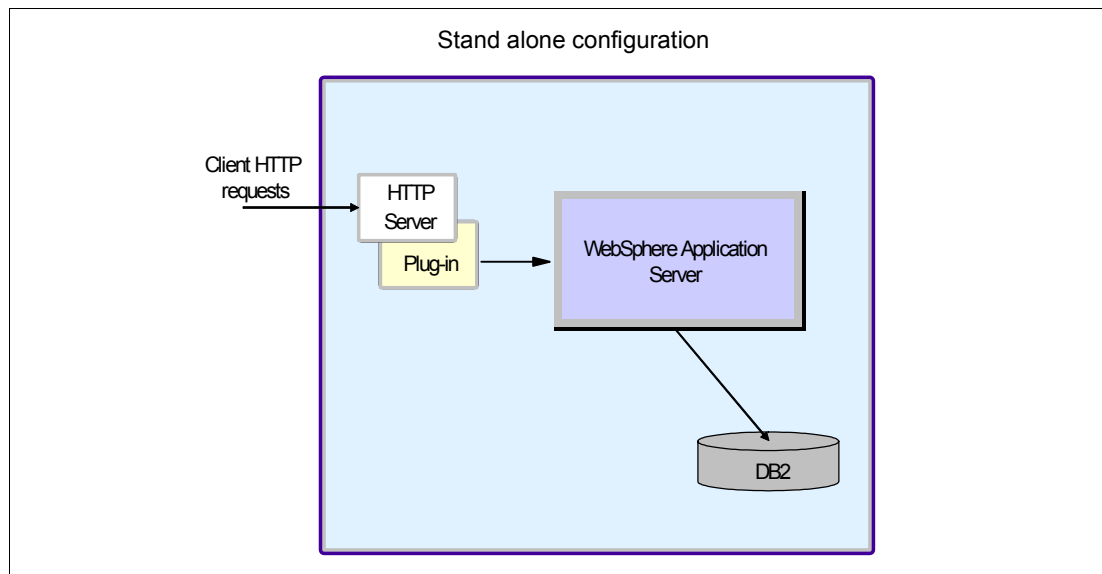

Figure 2-3 Stand alone configuration

When the application server and the Web server are placed in the same partition, there is no need to do additional HTTP Server Plug-in installation because the binaries are included in the WebSphere Application Server installation.

### 2.4.2 Remote Web server topology

If your application is accessed from an extranet or the Internet, you need to add some kind of protection to your environment. The first step is to isolate your production application server from the outside networks, which you can do by installing one or more Web servers in another partition(s) or machine(s), as shown in Figure 2-4 on page 23.

**Note:** The machine can run any supported Web server. You just need to install the HTTP server plug-in on this machine.

In this way, only the Web server is accessed from the outside network. To add another level of security, use firewalls as shown in Figure 2-4.

It is common to use multiple Web servers. There might be a Web server for internal access and another Web server for external access. Using multiple Web servers can also increase resiliency in the event of a failure. Figure 2-4 illustrates a topology where an external Web server is placed in the demilitarized zone (DMZ). Only ports needed for communication between the Web server and WebSphere Application Server are opened in the firewall.

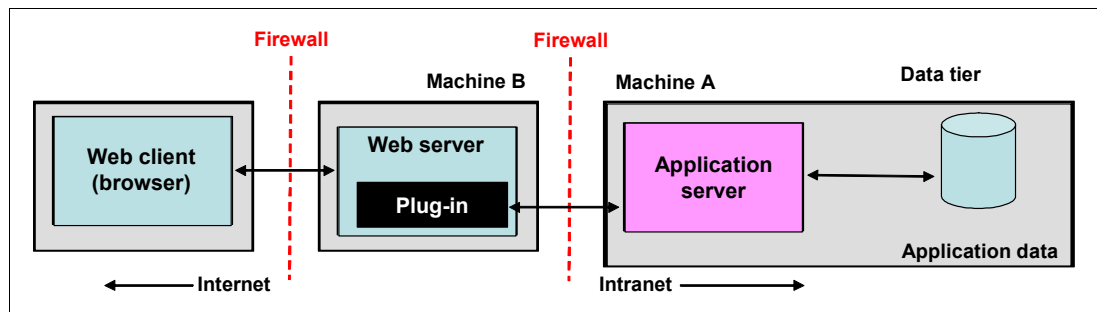

Figure 2-4 Using a remote Web server for Internet users

You can also use Secure Sockets Layer (SSL) to add more security to your topology. SSL allows you to encrypt all the communications between your Web server and the browsers connected to it. You can also configure SSL between the Web server and application server. If you do not use SSL, user IDs and passwords for the application will travel through the Internet in plain text, which is a potential security risk.

See Chapter 8, “Turning on security” on page 241 for more information about security.

### 2.4.3 Three-tier topology

The next logical step in improving the WebSphere topology is to isolate your database from the application server. In this configuration, WebSphere Application Server is installed on a different partition from the database. This configuration is common in large organizations where the data is shared between multiple types of applications.

In Figure 2-5, the database server is behind a second firewall. Only WebSphere Application Server can access the data.

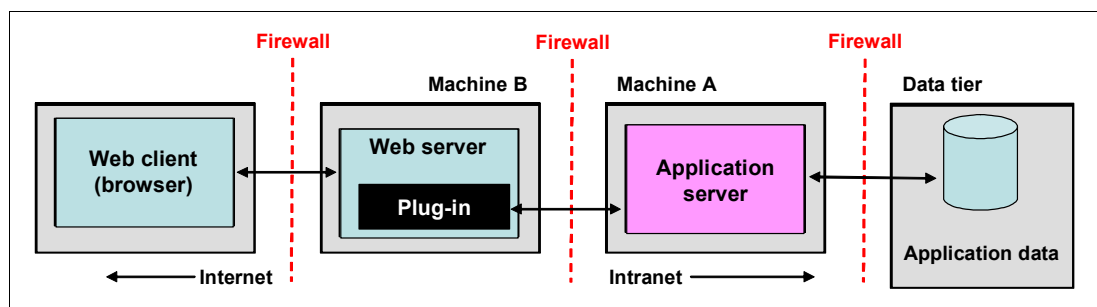

Figure 2-5 Three tier topology

## 2.4.4 High availability topology

With WebSphere Application Server Network Deployment, you can add additional high availability (HA) features to your WebSphere Application Server environment. We recommend a high availability topology for business-critical applications that are running on WebSphere Application Server. Remember that the System i server hardware has a lot of features to support high availability, such as:

- ▶ Redundant Power supplies
- ▶ Redundant Ethernet controllers
- ▶ Redundant disk controllers
- ▶ Cross-site mirroring for database replication

You can also increase the availability of your database and communications infrastructure by creating a cluster between two or more systems, as shown in Figure 2-6.

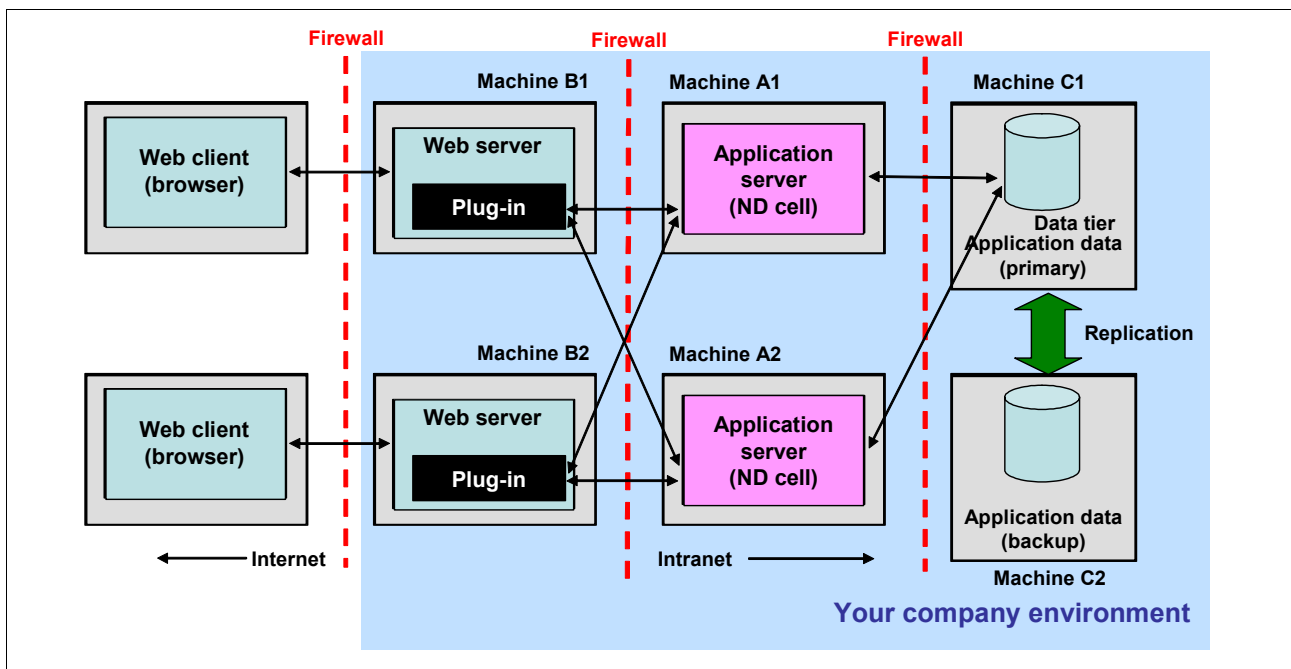

Figure 2-6 High availability topology

In Figure 2-6, we show six machines for overall WebSphere topology, but it is up to you to decide what number of systems you deploy to support a high availability solution.

For a detailed discussion of advanced topologies, such as the one in Figure 2-6, see the IBM Redbooks publication *WebSphere Application Server V6.1: Planning and Design*, SG24-7305.

## 2.5 Additional pre-installation considerations

We recommend that you review this section before you begin the WebSphere Application Server installation process. The additional pre-installation considerations are:

- ▶ Installation duration

WebSphere Application Server installation is Java-based and requires significant resources, which can sometimes result in long installation times in the order of several hours.

Consider installing WebSphere Application Server when there is no other workload in your i5/OS so that the installation process does not compete with other applications, for example, on the weekend. See the Information Center for estimated installation durations at:

[http://publib.boulder.ibm.com/InfoCenter/wasinfo/v6r1/index.jsp?topic=/com.ibm.websphere.base.iseries.doc/info/series/ae/rins\\_is\\_time.html](http://publib.boulder.ibm.com/InfoCenter/wasinfo/v6r1/index.jsp?topic=/com.ibm.websphere.base.iseries.doc/info/series/ae/rins_is_time.html)

- ▶ System availability

During the install process, the system may be restarted one or more times depending on your current level of Program Temporary Fixes (PTFs). Schedule installation to minimize the impact of system restarts.

- ▶ Review your system status

We recommend that you review your system status before you start the install. Verify that no hardware or software problems exist in the system:

- a. Start a 5250 emulator session and sign on.
- b. On the i5/OS command line, type `wrkmsg qsysopr`, and press Enter. You may see some error messages, such as those shown in Figure 2-7 on page 26.

```

                                Display Messages
                                System:      RCHAS07
Queue . . . . . : QSYSOPR           Program . . . . . : *DSPMSG
  Library . . . . :   QSYS           Library . . . . . :
Severity . . . . :   99           Delivery . . . . . : *HOLD

Type reply (if required), press Enter.
  Message CPA58EE reply ignored.
  Line PRIVATE failed. Automatic recovery started.
* Unable to establish a network link on Ethernet line PRIVATE
* Unable to establish a network link on Ethernet line PRIVATE
* Unable to establish a network link on Ethernet line PRIVATE
  Message CPA58EE reply ignored.
  Line PRIVATE varied on successfully.
  Controller PRIVANET contacted on line PRIVATE.
  User ALEKN started IP interface 192.168.9.2 on PRIVATE.
  Interface 192.168.9.2 is active.
  SNMP coldStart trap generated.
  SNMP linkUp trap generated.
  Job 002283/DHQB/ANZDFTPWD2 submitted for job schedule entry ANZDFTPWD2
                                                                More...
F3=Exit                F11=Remove a message          F12=Cancel
F13=Remove all         F16=Remove all except unanswered  F24=More keys
* - Work with problem allowed for message.

```

Figure 2-7 Display operator Messages

- c. To verify that no hardware or software problems exist in the system:
  - i. In an i5/OS command line, type wrkprb, and press Enter.
  - ii. Check the Hardware and Software problems display. Figure 2-8 on page 27 shows you an example of a hardware error in the system.

```

                                Work with Problems
                                System:  RCHAS07
Position to . . . . .          Problem ID

Type options, press Enter.
  2=Change  4=Delete  5=Display details  6=Print details
  8=Work with problem  9=Work with alerts  12=Enter text

Opt  Problem ID  Status      Problem Description
    0622033517  READY      Unable to establish a network link on Ethernet
    0622033512  READY      Unable to establish a network link on Ethernet
    0622033507  READY      Unable to establish a network link on Ethernet
    0621656531  READY      Unable to establish a network link on Ethernet
    0621656526  READY      Unable to establish a network link on Ethernet
    0621656522  READY      Unable to establish a network link on Ethernet
    0621632400  PREPARED   Fix request
  5  0621563217  READY      *Attention* Contact your hardware service pro
    0621562323  READY      *Attention* Contact your hardware service pro
    0621548338  READY      *Attention* Resource LIN01 failed.
                                                More...

F3=Exit      F5=Refresh  F6=Print list  F11=Display dates and times
F12=Cancel   F16=Report prepared problems  F24=More keys

```

Figure 2-8 Work with Problems

- iii. Type 5, and press Enter in the error line you want to review, to see the details of the error. See Figure 2-9 on page 28 for an example.

```

                                Display Problem Details
                                System:  RCHAS07
Problem ID . . . . . : 0621563217
Current status . . . . . : READY
Problem . . . . . : *Attention* Contact your hardware service
provider now.

Problem message ID . . . . . : CPPEA12
Problem type . . . . . : Machine detected
Problem category . . . . . : *CRITICAL
Date and time detected . . . . . : 08/03/06 18:24:48
System reference code . . . . . : SRC27638008
Reporting device type . . . . . : 2763
  Model . . . . . : 001
  Feature . . . . . :
  Serial number . . . . . : 10-2189062
  EC level . . . . . :

                                                                More...

Press Enter to continue.

F3=Exit  F5=Display possible causes  F6=Display problem history
F12=Cancel

```

Figure 2-9 Display Problem Details

iv. Press F5 to display possible causes for the problem, as shown in Figure 2-10.

```

                                Select Possible Cause Information
                                System:  RCHAS07
Problem ID . . . . . : 0621563217
Current status . . . . . : READY
Problem . . . . . : *Attention* Contact your hardware service
provide
r now.

Select one of the following:

    1. Problem analysis list

Selection

F3=Exit  F12=Cancel

```

Figure 2-10 Select Possible Cause Information

- v. Type 1, and press Enter to see the problem analysis list. "Display Problem Analysis Results" on page 29 shows that the cause of the problem is a cache battery that needs to be replaced, which is a common error that considerably increases the time of any type of installation in i5/OS.

```
Display Problem Analysis Results
System: RCHAS07
List type . . . . . : Isolation
Type options, press Enter.
5=Display detail
Opt  Probability  Possible Cause
      Cache battery pack
      I/O adapter card
Bottom
F3=Exit  F12=Cancel  F17=Top  F18=Bottom
```

Figure 2-11 Display Problem Analysis Results





# Installing WebSphere Application Server

In this chapter, we describe how to install WebSphere Application Server V6.1 on i5/OS. We also discuss the hardware and software prerequisites for installing this product on System i platform.

At the end of the chapter, we explain how to simplify the installation of a new environment, including profile creation and application deployment using IBM Installation Factory for WebSphere Application Server V6.1.

## 3.1 Installation checklist

Use this section as a checklist of steps for installing WebSphere Application Server products on i5/OS:

1. Prepare for the installation:
  - a. Review the Quick Start Guide CD, which shipped with your WebSphere Application Server installation CDs.
  - b. Read the product Release Notes for the WebSphere Application Server product. See <http://publib.boulder.ibm.com/InfoCenter/wasinfo/v6r1/index.jsp?topic=/com.ibm.websphere.base.iseries.doc/info/iseries/ae/v6rn.html>
  - c. Verify that your system meets all hardware and software prerequisites, and install prerequisite software if necessary:
    - For hardware requirements, see 3.2.1, “System i hardware requirements” on page 33
    - For software requirements, see 3.2.2, “System i and i5/OS software requirements” on page 33
  - d. Obtain and install the correct i5/OS cumulative PTF package. See 3.3.1, “Install prerequisite program temporary fixes” on page 35.
  - e. Check TCP/IP configuration. See 3.3.2, “Checking TCP/IP configuration” on page 37.
  - f. Check user profile authorization. See 3.3.3, “Checking your user profile authorization” on page 38.
  - g. Obtain the WebSphere Application Server product and current fixes.
2. Install WebSphere Application Server:
  - a. Install WebSphere Application Server on your System i server. See 3.4, “Performing WebSphere Application Server installation” on page 38.
  - b. Install the WebSphere Application Server group PTF. See “Installing the latest recommended WebSphere Application Server fixes” on page 53.
3. Configure WebSphere Application Server:
  - a. Configure the software license information. See 3.7.1, “Entering license information” on page 56.
  - b. Check the TCP/IP configuration for WAS install. See 3.7.2, “Verifying TCP/IP configuration” on page 57.
  - c. Configure the SQL Server® Jobs. See 3.7.4, “Configuring SQL jobs” on page 58.
  - d. Configure an HTTP Server to use with WAS. See Chapter 5, “Working with HTTP servers in WebSphere Application Server environment” on page 163.
4. Verify the installation:
  - a. Verify the installation. See “Verifying WebSphere Application Server installation” on page 60.

## 3.2 Prerequisites for WebSphere Application Server on i5/OS

To install WebSphere Application Server on i5/OS, verify that your hardware and software meets the minimum requirements.

**Important:** Check the following Web site for the latest information available about prerequisites:

<http://www-1.ibm.com/support/docview.wss?rs=180&uid=swg27007677>

### 3.2.1 System i hardware requirements

This section contains the minimum hardware requirements for a WebSphere Application Server installation. Systems not meeting the recommended requirements might be used in non-production environments where response times are not critical.

The minimum configuration we propose is based on the type of the applications you plan to deploy to WAS:

- ▶ If your applications contain enterprise beans:
  - IBM AS/400e model 170 with processor feature 2385 -AS/400e model 720 with processor feature 2062 -System i (iSeries) model 270 with processor feature 2250
  - System i model 820 with processor feature 2395
  - Minimum 750MB of physical memory in addition to the memory that is required for any other applications that are running on your System i server
- ▶ If your applications consist solely of servlets and JSP files:
  - System i model 270 with processor feature 2250
  - System i model 820 with processor feature 2395
  - Minimum 750MB of physical memory in addition to the memory that is required for any other applications that are running on your System i server
- ▶ Disk space requirements:
  - WebSphere Application Server: 900MB
  - WebSphere Application Server samples: 80MB
  - Application client: 160MB
  - Web server plug-ins: 100MB

**Important:** These values are the minimum configuration. We recommend at least 1 GB of additional memory for each profile that is running on the system.

### 3.2.2 System i and i5/OS software requirements

The software required to install and run WebSphere Application Server is as follows:

- ▶ i5/OS
  - WebSphere Application Server V6.1 is supported on i5/OS Version 5 Release 3 (V5R3) or Version 5 Release 4 (V5R4). The server must be in an unrestricted state, and your user profile must have \*ALLOBJ and \*SECADM special authorities.
- ▶ IBM Developer Kit for Java, Version 5 (5722-JV1 option 7)
  - Required for installation.
- ▶ i5/OS Qshell (5722-SS1 option 30)
  - Required to run installation scripts and to use other scripts in WebSphere Application Server.

- ▶ i5/OS Host Servers (5722-SS1 option 12)  
Required for installation.
- ▶ i5/OS Extended Base Directory Support (5722-SS1 option 3)  
Required for installation.
- ▶ i5/OS Portable Application Solutions Environment (5722-SS1 option 33)  
Required by the application server runtime and Tivoli® Performance Viewer.
- ▶ All necessary fixes  
For a list of current fixes, see the following Web site, and click the link under the *PTF* heading for the installed version of i5/OS:  
<http://www-03.ibm.com/servers/eserver/series/software/websphere/wsappserver/indexdexb61.html>

### 3.2.3 i5/OS optional software

The optional software is as follows:

- ▶ HTTP Server

An HTTP Server is not required for installation, but we recommend it for production environments that use servlets and JSP files.

WebSphere Application Server supports the following HTTP server products on i5/OS:

- IBM HTTP Server (powered by Apache) (5722-DG1)
- Lotus Domino for iSeries 6.5 (5733-L65)
- Lotus Domino for iSeries 7.0 (5733-LD7)

IBM HTTP Server for iSeries (5722-DG1) can help you to perform some administrative tasks related to your WAS environment.

**Note:** WebSphere Application Server supports the HTTP servers running on other platforms. For a complete list of supported HTTP server, read the following Web page:  
<http://www-1.ibm.com/support/docview.wss?rs=180&uid=swg27007677>

- ▶ IBM HTTP Server for System i group PTF (for managing application servers)
  - V5R3M0 / V5R3M5: level 10 or higher
  - V5R4M0: level 4 or higher
- ▶ i5/OS Digital Certificate Manager (5722-SS1 option 34)  
The i5/OS Digital Certificate Manager is not required for installation, but it is required if you plan to configure WebSphere Application Server to use Secure Sockets Layer (SSL) protocol.
- ▶ DB2 Query Manager and SQL Development Kit for iSeries (5722-ST1)  
The DB2 Query Manager and SQL Development Kit for iSeries helps you to develop client applications.
- ▶ IBM Technology for JVM (5722-JV1 option 8)  
Required if you want to use the new 32-bit JVM in V5R4 to run WebSphere Application Server, rather than the default Classic 64-bit JVM. See Chapter 11, “Running WebSphere Application Server with IBM Technology for Java VM” on page 379.

## 3.3 Preparing i5/OS for installation

Before installing WebSphere Application Server be sure that your system is configured properly by following the guidance we provide in this section.

### 3.3.1 Install prerequisite program temporary fixes

Program temporary fixes (PTFs) resolve known issues in i5/OS and related products, and some add new functionality to your software.

Table 3-1 contains the minimum PTF levels that are required for installing WebSphere Application Server v6.1.

Table 3-1 Minimum PTF levels required for WebSphere Application Server v6.1 on i5/OS

i5/OS version	Cumulative level	Java group level
V5R3M0 / V5R3M5	C6101530 or later	11 or higher
V5R4M0	C6066540 or later	3 or higher

We recommend that you implement the latest available group PTFs before you install your WebSphere Application Server V6.1 Software, which includes:

- ▶ i5/OS Cumulative PTF package
- ▶ Hiper
- ▶ DB2 Universal Database for iSeries
- ▶ Java
- ▶ IBM HTTP Server

**Important:** You must always ensure that you install the product before you install the related group PTF package, for example, ensure that you install the IBM Developer Kit for Java 1.5 (5722-JV1, Option 7) before you install the Java group PTF package.

**Note:** For our installation, we used a system with V5R4M0 and CUM level C6192540. Also we installed Java Group PTF level 3 before we performed the installation.

Use the following steps to determine the current i5/OS Cumulative and Java Group PTF levels on your system:

1. Enter the Display PTF Status (DSPPTF) command in a command line. The Display PTF Status window is displayed. The window lists all of the PTFs that were applied to your server. To view the PTFs for all products, press the Enter key repeatedly.

Figure 3-1 on page 36 shows an example of the Display PTF status window for the 5722SS1 product. The first *Temporarily applied* PTF is the latest Cumulative PTF marker, in this case TC06192.

```

                                Display PTF Status
                                System:   RCHAS07
Product ID . . . . . : 5722SS1
IPL source . . . . . : ##MACH#B
Release of base option . . . . . : V5R4M0 L00

Type options, press Enter.
  5=Display PTF details  6=Print cover letter  8=Display cover letter

   PTF
Opt ID      Status                                IPL
                                     Action
TC06192 Temporarily applied                      None
TC06115 Superseded                               None
TC06066 Superseded                               None
TC06024 Superseded                               None
TC05354 Superseded                               None
TC05326 Superseded                               None
TCP0040 Temporarily applied                      None
TCP0039 Superseded                               None
TCP0038 Superseded                               None
More...

F3=Exit  F11=Display alternate view  F17=Position to  F12=Cancel

```

Figure 3-1 Check current i5/OS Cumulative PTF level

2. Check your current Java Group PTF level by running the WRKGRPPTF command. Figure 3-2 shows the different PTF level for each PTF group.

```

                                Work with PTF Groups
                                System:   RCHAS07

Type options, press Enter.
  4=Delete  5=Display  6=Print  8=Display special handling PTFs
  9=Display related PTF groups

Opt PTF Group          Level Status
   SF99540             6192 Installed
   SF99539              19 Installed
   SF99315              2 Installed
   SF99291             3 Installed
   SF99186              7 Installed
   SF99173              3 Installed
   SF99114              4 Installed

Bottom
F3=Exit  F6=Print  F11=Display descriptions  F12=Cancel
F22=Display entire field

```

Figure 3-2 Check current Java Group PTF level

3. Press F11 to see the Group PTF names, as shown in Figure 3-3 on page 37.

```

                                Work with PTF Groups
                                System:  RCHAS07

Type options, press Enter.
  4=Delete  5=Display  6=Print  8=Display special handling PTFs
  9=Display related PTF groups

Opt  PTF Group                Text
     SF99540                  CUMULATIVE PTF PACKAGE C6192540
     SF99539                  GROUP HIPER
     SF99315                  TCP/IP GROUP PTF
     SF99291                  JAVA
     SF99186                  BACKUP RECOVERY SOLUTIONS
     SF99173                  IBM BUSINESS SOLUTIONS
     SF99114                  IBM HTTP SERVER FOR I5/OS

Bottom
F3=Exit  F6=Print  F11=Display status  F12=Cancel
F22=Display entire field

```

Figure 3-3 Pressing F11 in Work with PTF Groups shows the names

**Attention:** Later, when you start the installation process, the installation wizard checks the system for any missing PTFs that are required for successful installation. See 3.4, “Performing WebSphere Application Server installation” on page 38 for more information.

You can view and download the latest available Group PTFs at the Fix Central Web site:

<http://www.ibm.com/eserver/support/fixes/fixcentral/main/series>

If you require any cumulative PTF packages or individual PTFs in preparation for installing WebSphere Application Server V6.1, you can also download these items directly to your system through Fix Central. For more detailed information about how to order and download PTFs from Fix Central, refer to Appendix A, “Downloading PTFs using Fix Central” on page 399.

### 3.3.2 Checking TCP/IP configuration

To install WebSphere Application Server v6.1 on i5/OS, TCP/IP must be configured properly and must be started before you start installation.

You must check the following TCP/IP parameters:

- ▶ Host name and domain name are correctly defined.
- ▶ Your TCP/IP interfaces are defined and started.
- ▶ Verify that you can access the system using its host name because you must define the host name in hosts table entries or include it in your DNS Server table.
- ▶ The Host servers must be started for installation purposes. However you do not need to start them in order to run WebSphere Application Server. For security reasons, you can stop them after installation is complete.

Visit the Information Center Web pages for more information about configuring TCP/IP in your i5/OS:

- ▶ For V5R3M0:

<http://publib.boulder.ibm.com/infocenter/iseriess/v5r3/index.jsp?topic=/rzai2/rzai2kickoff.htm>

- ▶ For V5R4M0:

<http://publib.boulder.ibm.com/infocenter/iseriess/v5r4/index.jsp?topic=/rzai2/rzai2kickoff.htm>

### 3.3.3 Checking your user profile authorization

To start the installation of WebSphere Application Server v6.1, make sure that your user profile has \*ALLOBJ and \*SECADM special authorities. The installation will fail if the user profile has insufficient privileges.

## 3.4 Performing WebSphere Application Server installation

In this section, we describe three ways to install WebSphere Application Server V6.1 on i5/OS:

- ▶ Remote GUI install from a Windows workstation
- ▶ Remote silent install from a Windows workstation
- ▶ Local silent install from i5/OS QShell command line

In the following sections, we describe the procedures for the different methods of installing WebSphere Application Server.

### 3.4.1 Remote GUI installation

The GUI installation method is the easiest way to install your WebSphere Application Server.

**Tip:** We recommend that you use this method if you are going to install a simple environment. Do not use it, however, if you have a slow network connection between your server and workstation or if there is a firewall that does not permit access to the hosts' servers' ports.

To install WebSphere Application Server V6.1 from a workstation using the graphical installation method, use the following procedure:

1. Start a 5250 emulator session and sign on.
2. Start hosts servers. From a i5/OS command line type STRHOSTSVR SERVER(\*ALL), and press Enter.
3. Locate your WebSphere Application Server V6.1 for i5/OS CD, and insert it into a CD or DVD drive on your Windows workstation. If your workstation has autostart configured, the launchpad starts. If the autostart program is not executed, locate the launchpad.exe file on the CD, and execute it.

**Attention:** Do not accidentally use any of the multi platform CDs that are shipped with your software. Ensure that you are using the WebSphere Application Server V6.1 for i5/OS CD.

4. Press the **Launch the installation wizard for WebSphere Application Server** link (Figure 3-4), and the WebSphere Application Server installer starts.

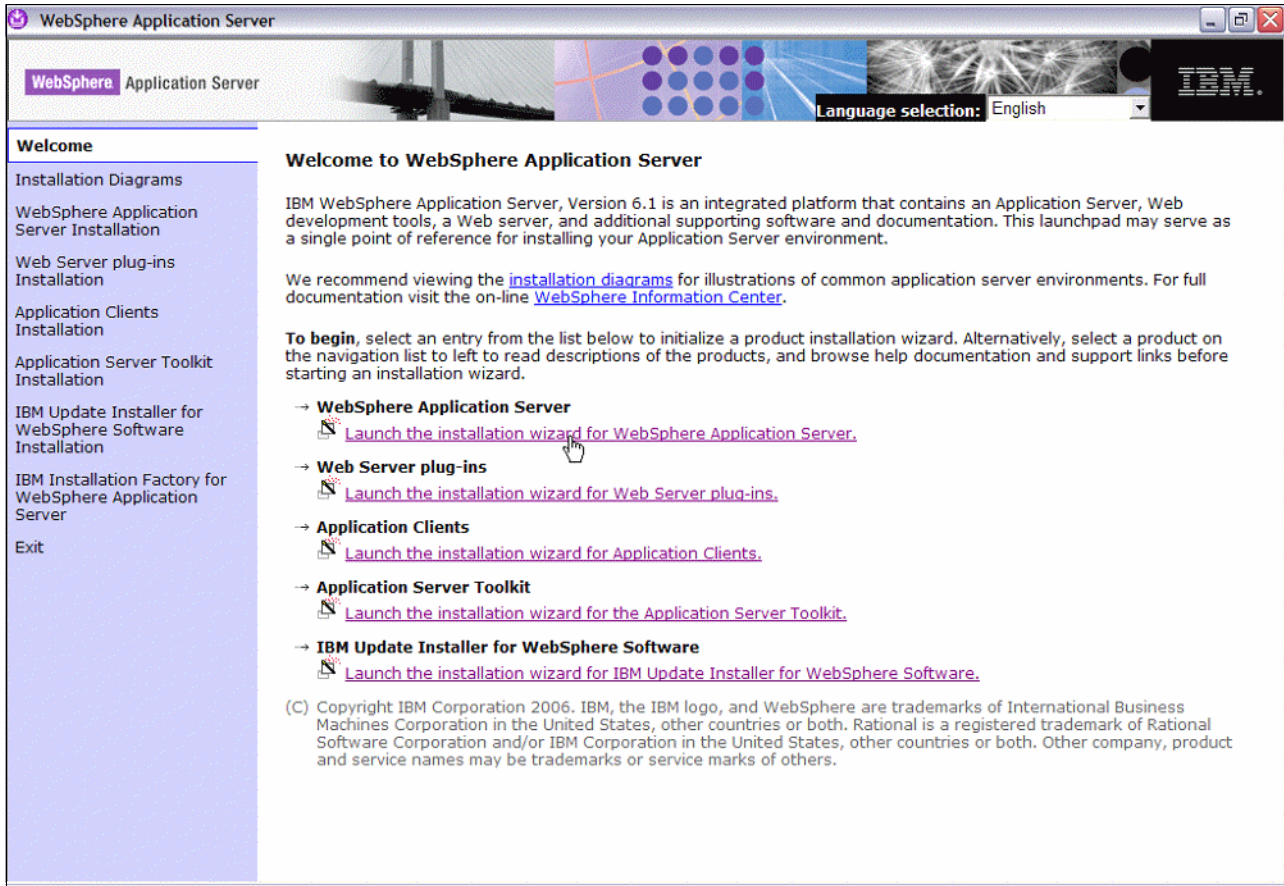

Figure 3-4 WebSphere Application Server launchpad

5. On the Login Information panel (Figure 3-5), type your i5/OS host name or IP Address, User ID, and Password. Click **OK**.

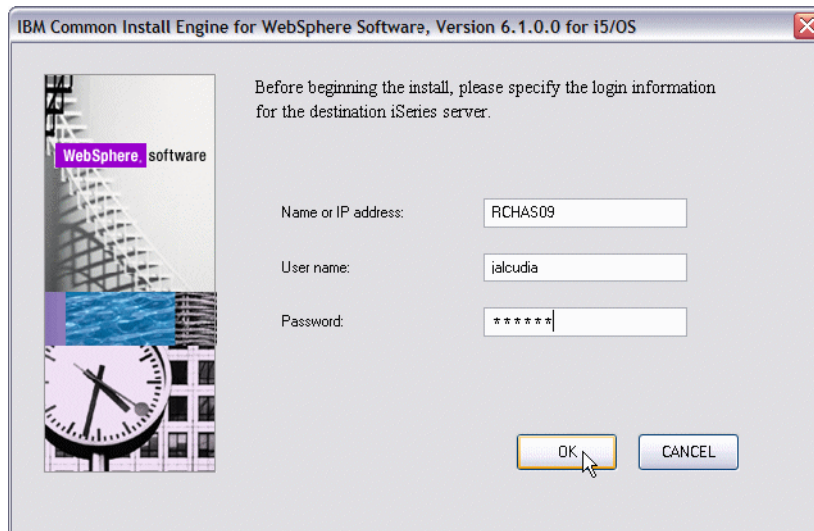

Figure 3-5 Entering i5/OS login information

6. If your host name, user ID, and password are correct, and there is a connection between your workstation and the i5/OS server, the Welcome panel (Figure 3-6) will display. Click **Next**.

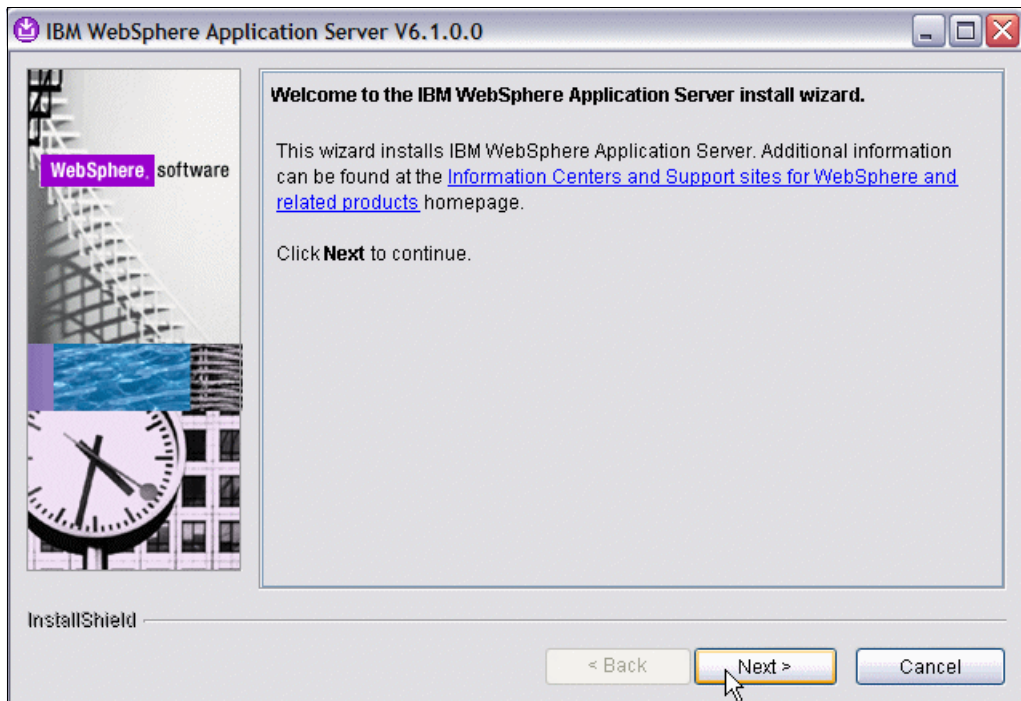

Figure 3-6 The WebSphere Application Server installation Welcome window

**Note:** The Welcome window has a link to the installation section of the Information Center.

7. In the Software License window (Figure 3-7 on page 41), you must accept the International Program License Agreement to continue with the install. Click **I accept both the IBM and the non-IBM terms**, and click **Next**.

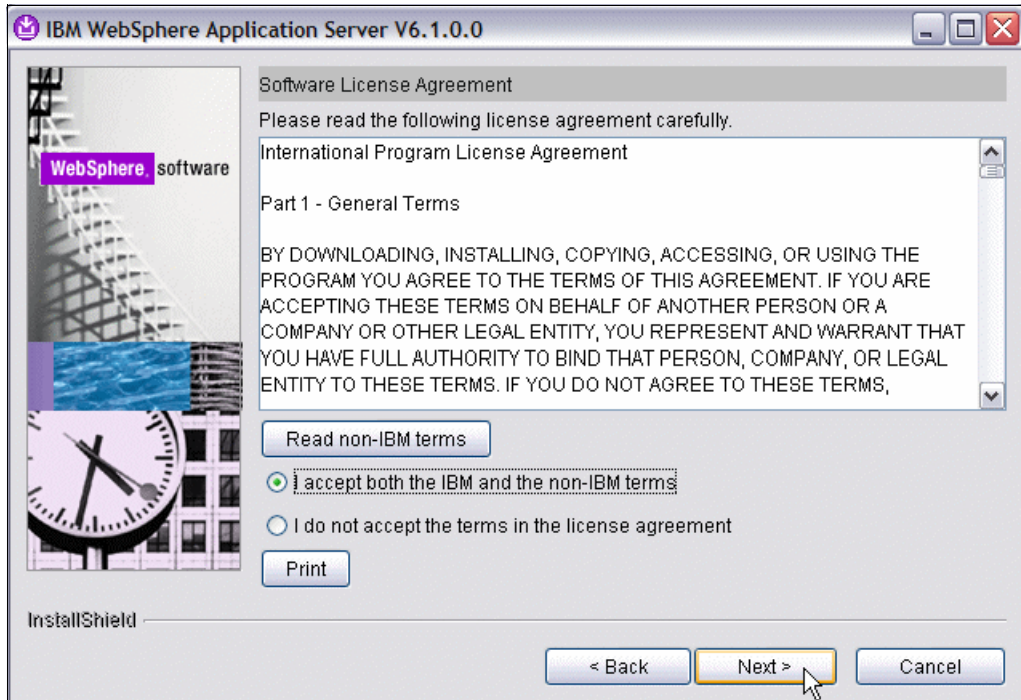

Figure 3-7 You must accept the terms of the Software License Agreement to proceed

8. The installer now checks if the system meets the prerequisites. If all prerequisites are met, the System prerequisites check window, Figure 3-8, appears. Click **Next**.

If some prerequisites are missing, the installation wizard reports an error. See 3.9, “Troubleshooting the WebSphere Application Server 6.1 installation” on page 77 for more information.

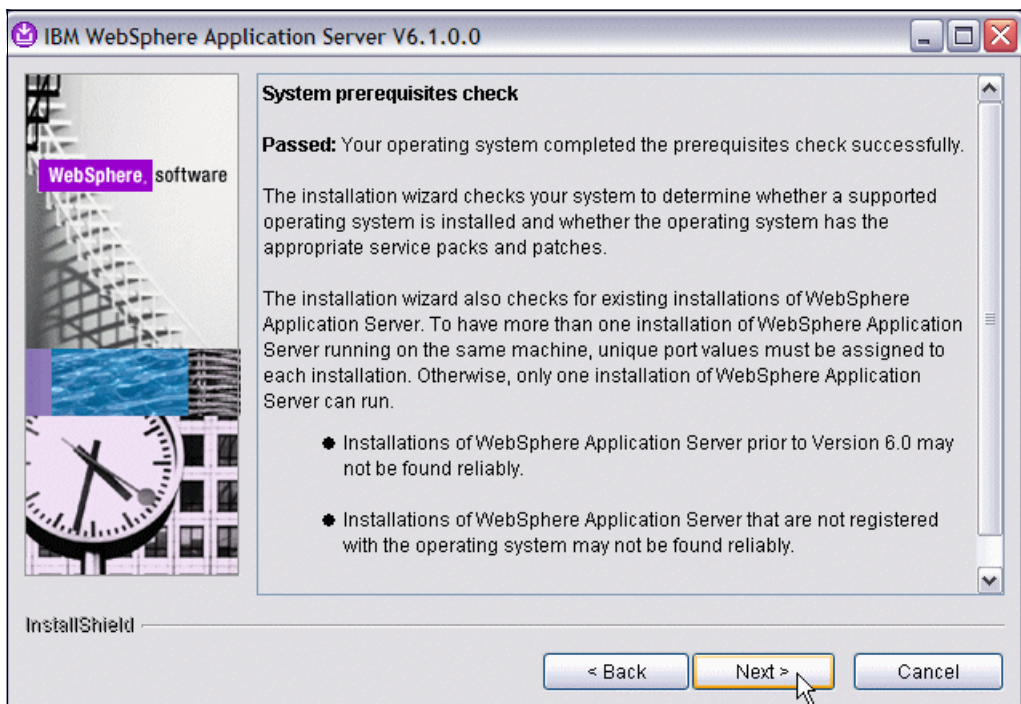

Figure 3-8 Prerequisites OK

9. Next, decide if you want to install the Sample Applications or not. The DefaultApplication (containing the snoop, hello, and hitcount samples) is always installed. If you decide not to install the application samples, you can always install them at a later time simply by running the install wizard again and choosing to update the existing installation.

Select the check box next to **Install the sample applications** (Figure 3-9), and click **Next**.

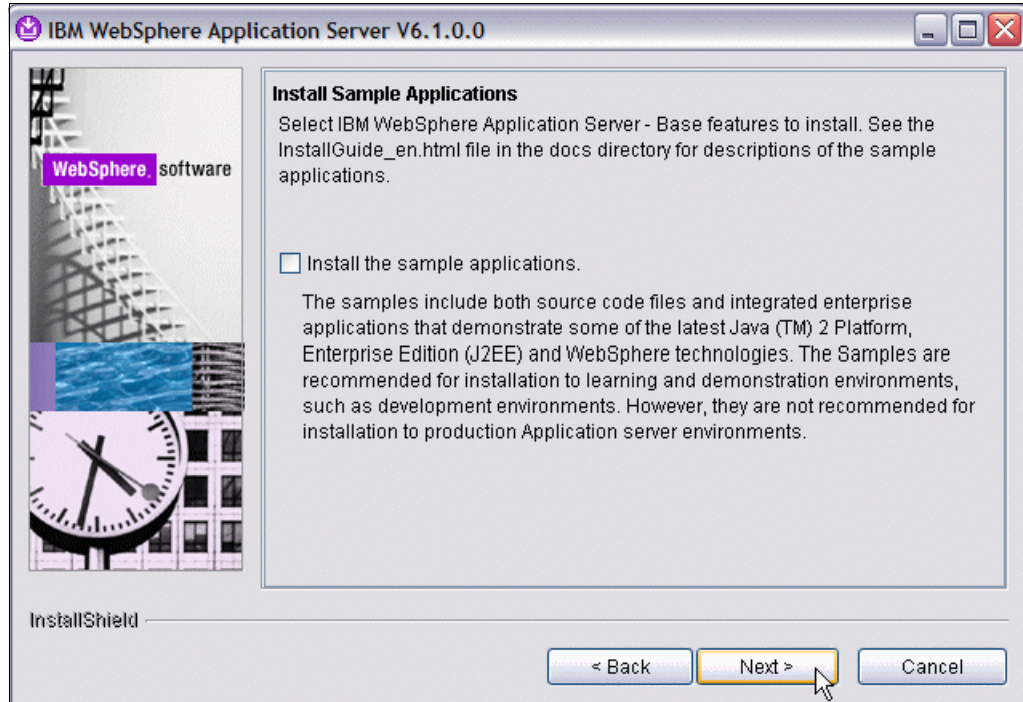

Figure 3-9 Choose if you wish to install sample applications

10. Figure 3-10 on page 43 shows one of the most important screens in the installation. Because WebSphere Application Server V6.1 supports multiple product installations, you can specify where to install your application server binaries and profiles. If you do not plan to install WebSphere Application Server several times, we recommend that you do not change the default product install values, which makes it easier for IBM Support to assist you, if you need assistance in the future.

There are several scenarios that influence your choice of installation location:

- If there is an existing installation in the default location, the install wizard presents an alternative location created by adding a number to the path, for example:

`/QIBM/ProdData/WebSphere/AppServer/V61/Base1`

**Note:** The install location must be empty or nonexistent to proceed.

- If WebSphere Application Server Express is already installed on the system, and you choose to install Base, the installer prompts you to upgrade the Express install to Base. You can choose to install a new copy of WebSphere Application Server instead of upgrading.

The product library for the install is determined by the system.

Click **Next**.

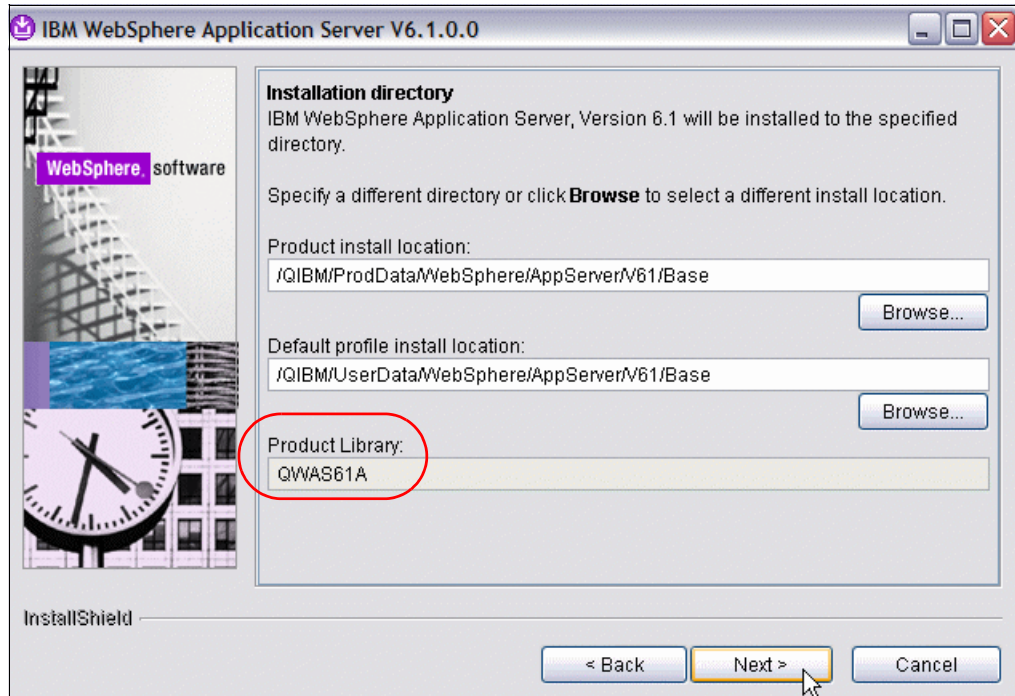

Figure 3-10 WebSphere Installation directory

11. You can now enable administrative security during installation (Figure 3-11 on page 44). The user name does *not* need to be a local user ID or an LDAP user. The user ID and password you enter are stored in a repository that is created automatically while administrative security is enabled.

**Note:** Enabling administrative security only applies to the default profile created at installation. It does not affect any subsequent profiles you create.

Choose one of two options:

- Type user name and password, if enabling administrative security.
- Clear the check box, if you do not want to enable administrative security at install time.

Click **Next**.

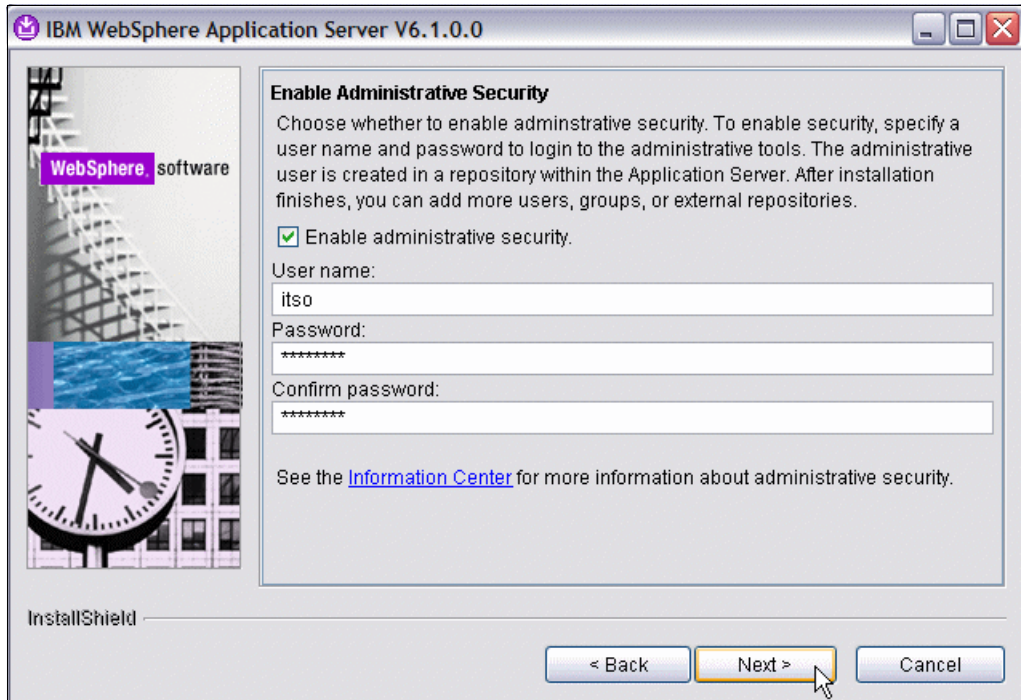

Figure 3-11 Enabling Administrative Security at install time

12. The Installation Summary window (Figure 3-12) shows the parameters you chose for the installation. You can change any parameter that is incorrect by pressing the **Back** button. If everything is correct, click **Next** to start the installation.

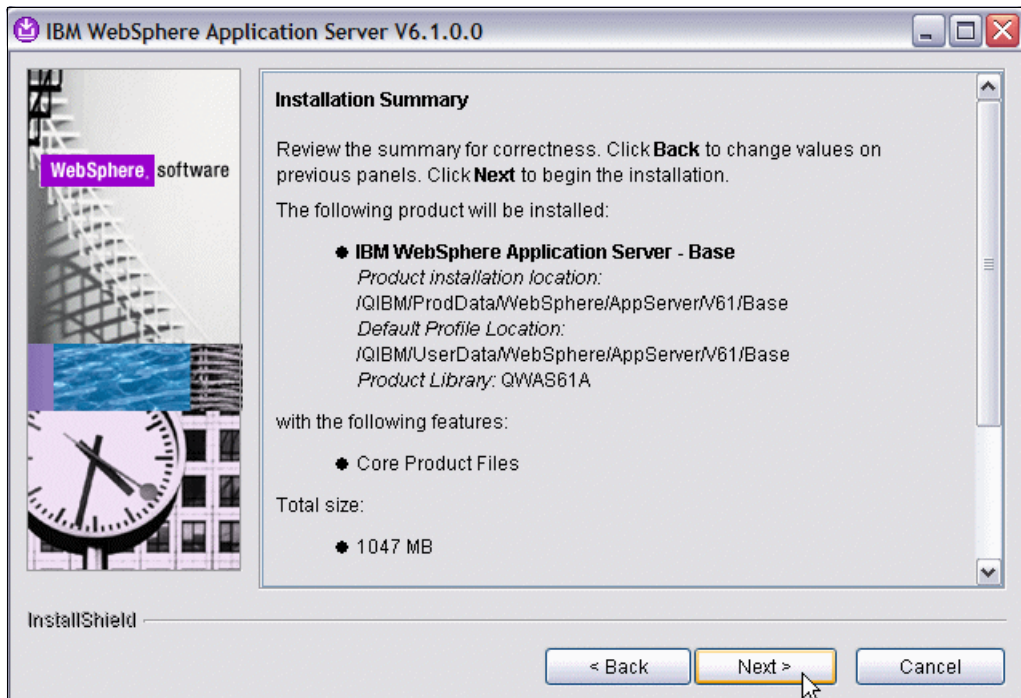

Figure 3-12 Installation Summary window

The installation starts, and you can see the progress window, Figure 3-13, which we show several different captures of:

- The uninstaller is created.
- Product files are laid down component by component.
- The installer runs the install configuration actions.

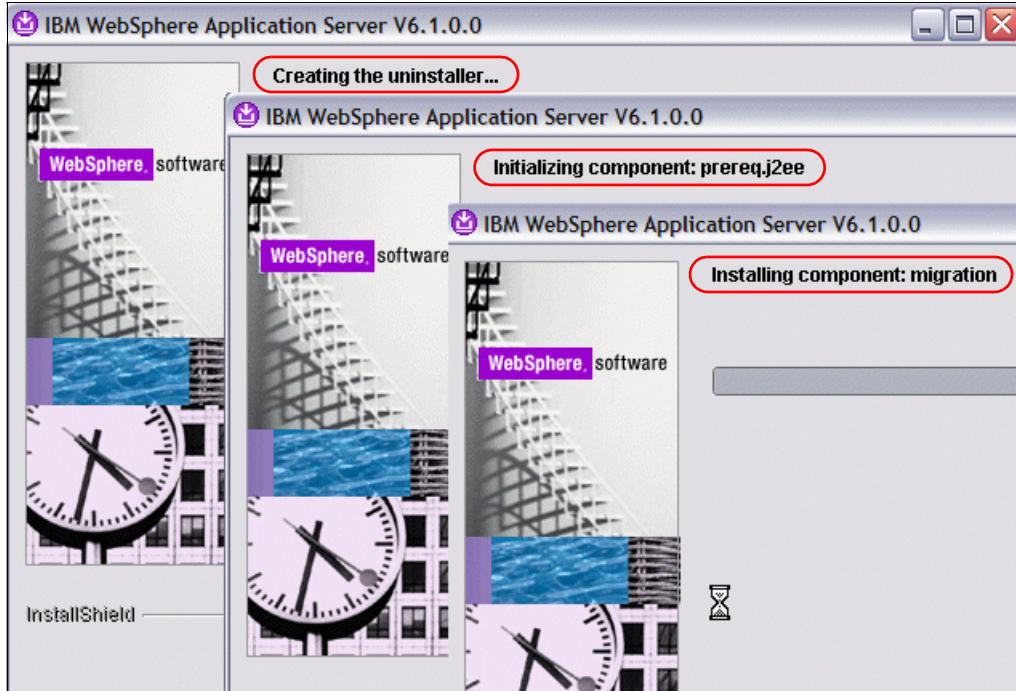

Figure 3-13 The WebSphere installation process

13. At the end of the process, the Installation Results panel (Figure 3-14 on page 46) is displayed, which shows if the installation was successful or not. It also shows the type of profile created.

Click **Finish** to exit the wizard.

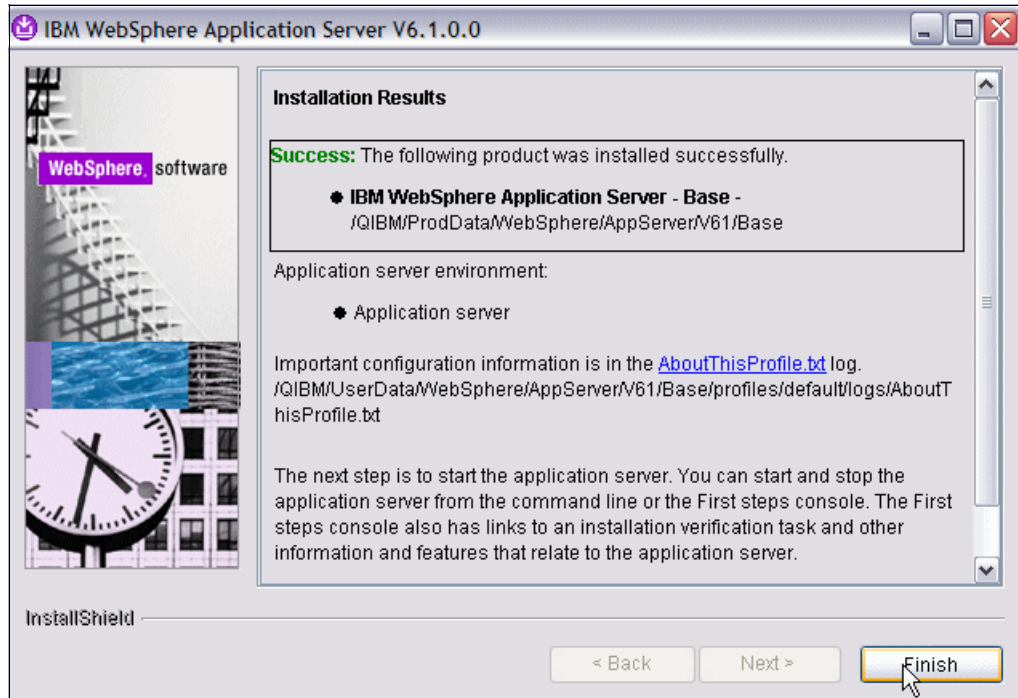

Figure 3-14 The Installation Results panel showing a successful installation

14. If the installation is successful, the system shows you the First steps window (Figure 3-15). Press **Installation verification** to confirm that the WebSphere Application Server installation was successful.

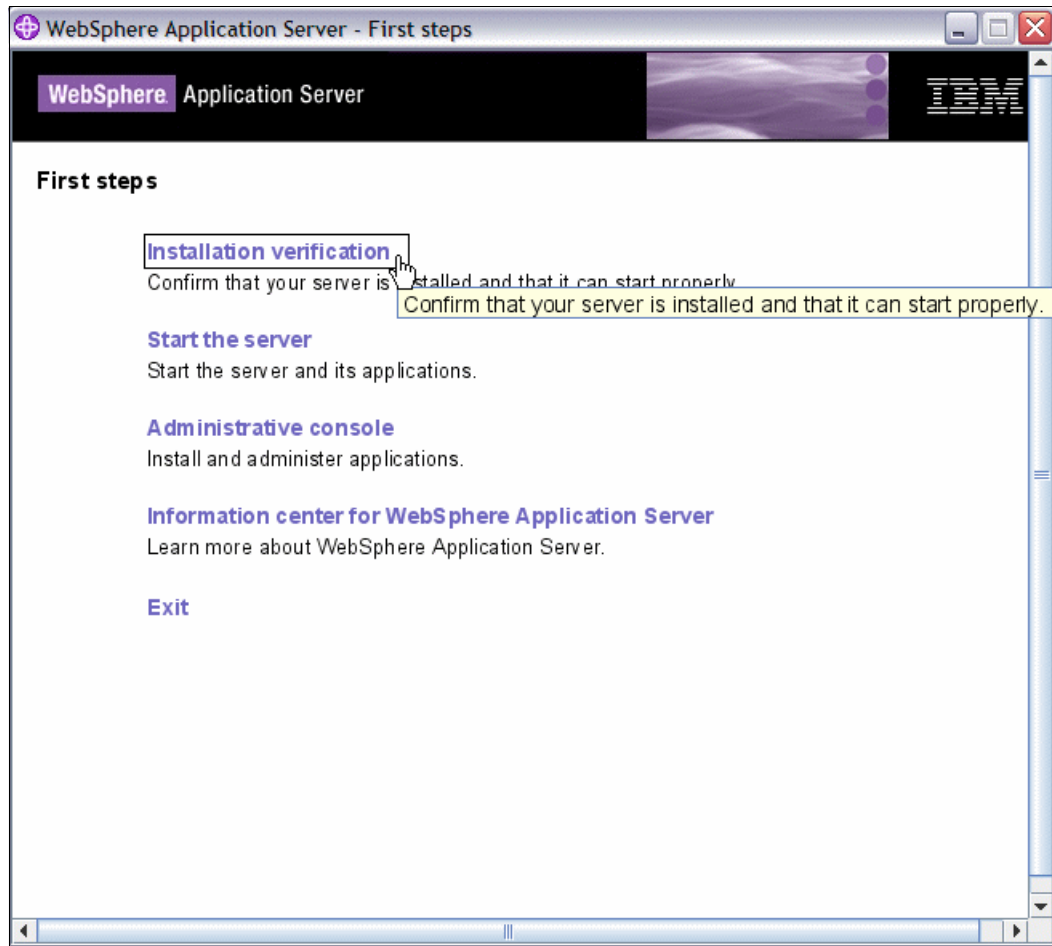
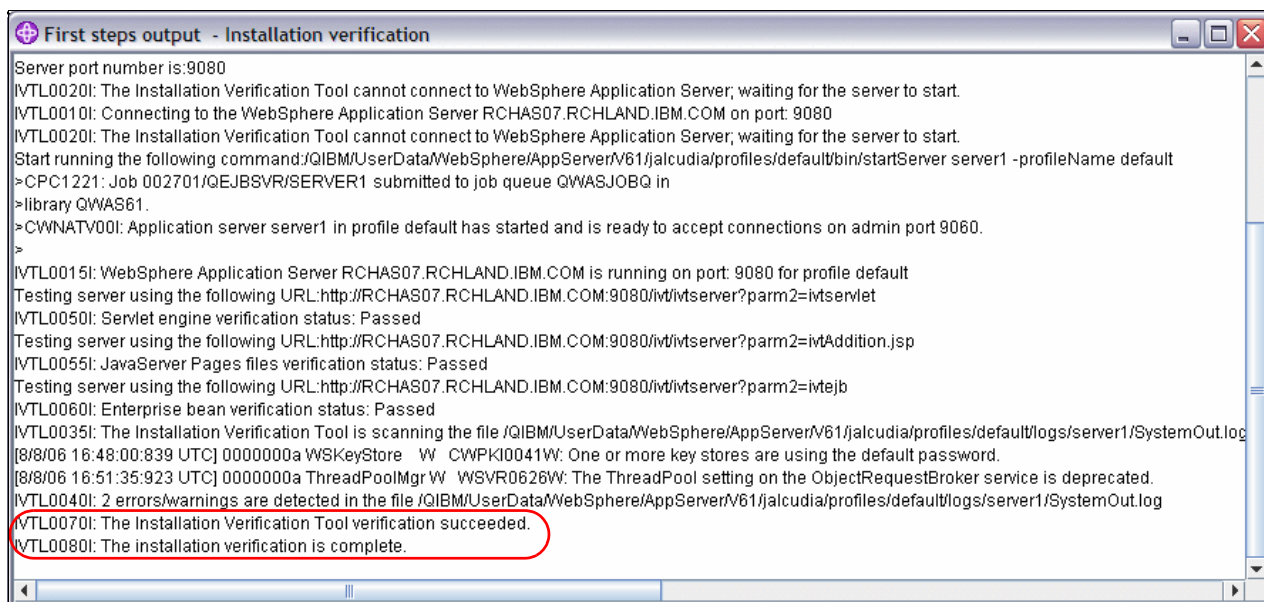

Figure 3-15 Firsts Step console

Installation verification starts the server for you and runs some simple verification tests.

Figure 3-16 shows the result of the installation verification procedure.



```
Server port number is:9080
IVTL0020: The Installation Verification Tool cannot connect to WebSphere Application Server; waiting for the server to start.
IVTL0010: Connecting to the WebSphere Application Server RCHAS07.RCHLAND.IBM.COM on port: 9080
IVTL0020: The Installation Verification Tool cannot connect to WebSphere Application Server; waiting for the server to start.
Start running the following command:/QIBM/UserData/WebSphere/AppServer/V61/jalcudia/profiles/default/bin/startServer server1 -profileName default
>CPC1221: Job 002701/QEJBSVR/SERVER1 submitted to job queue QWASJOBQ in
>library QWAS61.
>CWNATV00: Application server server1 in profile default has started and is ready to accept connections on admin port 9060.
>
IVTL0015: WebSphere Application Server RCHAS07.RCHLAND.IBM.COM is running on port: 9080 for profile default
Testing server using the following URL:http://RCHAS07.RCHLAND.IBM.COM:9080/ivt/ivtserver?parm2=ivtserverlet
IVTL0050: Servlet engine verification status: Passed
Testing server using the following URL:http://RCHAS07.RCHLAND.IBM.COM:9080/ivt/ivtserver?parm2=ivtAddition.jsp
IVTL0055: JavaServer Pages files verification status: Passed
Testing server using the following URL:http://RCHAS07.RCHLAND.IBM.COM:9080/ivt/ivtserver?parm2=ivtejb
IVTL0060: Enterprise bean verification status: Passed
IVTL0035: The Installation Verification Tool is scanning the file /QIBM/UserData/WebSphere/AppServer/V61/jalcudia/profiles/default/logs/server1/SystemOut.log
[8/8/06 16:48:00:839 UTC] 0000000a WSKKeyStore W CWPk10041W: One or more key stores are using the default password.
[8/8/06 16:51:35:923 UTC] 0000000a ThreadPooMgr W WSVR0626W: The ThreadPool setting on the ObjectRequestBroker service is deprecated.
IVTL0040: 2 errors/warnings are detected in the file /QIBM/UserData/WebSphere/AppServer/V61/jalcudia/profiles/default/logs/server1/SystemOut.log
IVTL0070: The Installation Verification Tool verification succeeded.
IVTL0080: The installation verification is complete.
```

Figure 3-16 Installation Verification results

15. Click the **Start the server** link to start the server if you created a profile during the install. You can also open the administration console and the Information Center pages from the First steps console.

**Restriction:** Unlike WebSphere Application Server for Multiplatforms, the installer does not copy the First Steps Console to a directory on the server. So you can only execute it at install time from the CD on your workstation.

### 3.4.2 Silent installation

Instead of using an interactive GUI-based installation, you can choose to install the product using a silent installation. Silent installation reads the required parameters from a *response file* that you populate beforehand. You can run the silent installation remotely (from a Windows workstation) or locally on the i5/OS server.

The silent installation can be useful when you need to perform installation on multiple systems by saving you time and effort interacting with the GUI. Use the local silent installation when there is a poor or no network connection between your Windows workstation and your System i server.

Both the local and remote silent installations use a response file. A sample response file is located under the WAS directory on the CD for your convenience. The file name is responsefile.<edition>.txt, for example the sample response file for WebSphere Application Server Base is responsefile.base.txt.

#### Remote silent install

To perform the remote silent install from your Windows workstation, follow these steps:

1. Start a 5250 emulator session and sign on.

2. Start hosts servers. On an i5/OS command line, type STRHOSTSVR SERVER(\*ALL), and press Enter.
3. Verify that your user profile has the \*ALLOBJ and \*SECADM special authorities.
4. Place the WebSphere Application Server for i5/OS CD in the disc drive of your Windows workstation. When the autorun feature brings up the GUI, click **Cancel** to exit the GUI.

**Important:** Do not use the WebSphere Application Server, Version 6.1 for Windows CD or any other operating system CD, other than the CD for i5/OS.

5. On your Windows workstation open Windows Explorer, and access the license information location in <disk\_drive>:\WAS\DOCS\lfiles. Make sure you agree with the license conditions.

**Note:** If you install from a DVD, the installation files on this DVD are grouped based on the targeted operating system; therefore, you need to switch to the directory that is specific to your operating system, in our example - i5/OS.

6. Open a command prompt on your Windows workstation.
7. Copy the response file from the disc directory to a directory on your Windows workstation, such as the C:\temp directory, for example:

```
copy <disk_drive>:\WAS\responsefile.base.txt C:\temp\RESPONSEFILE
```

8. Open the copied file with your favorite text editor, for example:

```
notepad C:\temp\RESPONSEFILE
```

9. Change the response file as required for your installation. We describe most of the parameters in this step. Modify only those parameters that you need:
  - Change the following parameter to true in order to accept the license:
 

```
-OPT silentInstallLicenseAcceptance="false"
```

 If you do not accept the license, the installation will fail.
 

```
-OPT PROF_adminUserName=
```
  - If you want to enable security for the created WebSphere profile, type your user name for administrative security. It can be any name, not necessarily an operating system or LDAP user ID.
 

```
-OPT PROF_adminPassword=
```

 Specify password for *adminUserName*.

**Attention:** Do not forget the user name and password because you need them to logon to your Administrative Console.

- Change the following parameter to false if you do not want to enable administrative security. You do not need to set the PROF\_adminUserName or PROF\_adminPassword in this case.
 

```
-OPT PROF_enableAdminSecurity="true".
```
- Remove the “#” to uncomment the line if you do not want to create a profile during installation, which saves a lot of time during the install.
 

```
#-OPT profileType="none".
```

- Change the following parameter to “Samples” if you want to install Sample Applications. The DefaultApplication (containing snoop, hello, and hitcount samples) is always installed:

```
-OPT feature="onFeature"
```

- You can override the check for correct PTF levels if you uncomment this line. We recommend not to override if you are unsure whether the product will work correctly without the prerequisites:

```
#-OPT disableOSPrereqChecking="true"
```

- If you install the product multiple times or do not wish to install the product in the default location, change the following value to a desired path in IFS

```
-OPT installLocation="defaultInstallLocation"
```

Example: /QIBM/ProdData/WebSphere/AppServer/V61/Base\_AVN

- You can change the following value, which is the install location for the user files (profile data):

```
-OPT defaultProfileLocation="defaultProfileLocation"
```

- The following value allows you to install the product to an existent, non-empty location. This situation is possible if your previous installation failed and you try to reuse the same directory.

```
-OPT allowOverrideProfileLocation="true"
```

- Change the value to “*upgrade*” to upgrade an Express install to a Base install.

Change the value to “*addFeature*” if you want to add features to an existing install (remember that only the Samples feature can be added for WebSphere Application Server and you must change the -OPT feature to “samplesSelected”)

For both cases ensure that installLocation and defaultProfileLocation specify the values for the original install.

```
-OPT installType=
```

10. Save your changes.

11. Change the directory to the WAS subdirectory of the CD, for example, if your CD drive letter is “D:”, run the following two commands:

```
D:
CD D:\WEBSHERE\WAS
```

12. Run install.exe, and point to your response file, for example:

```
install.exe <hostnameOrIP> userid password -options C:\temp\RESPONSEFILE
```

In the command above:

- hostnameOrIp: your System i platform host name or IP address
- userid: your i5/OS profile (with \*ALLOBJ and \*SECADM authority)
- password: your i5/OS user ID password

**Note:** Parameters are order dependent. If you do not specify all of the parameters, the GUI installation is invoked.

13. Periodically, check the <install\_root>/logs/install/log.txt log file in IFS to verify whether installation is complete.

## Local silent installation

To start the local silent installation:

1. Sign on to your server.
2. Start Hosts servers. On an i5/OS command line type STRHOSTSVR SERVER(\*ALL), and press Enter.
3. Verify that your user profile has the \*ALLOBJ and \*SECADM special authorities.
4. Place the WebSphere Application Server for i5/OS CD in the disc drive of your System i server.

**Important:** Do not use the WebSphere Application Server, Version 6.1 for Windows CD, or any other operating system CD, other than the CD for i5/OS.

5. Use the Copy (CPY) command to create a copy of the responsefile.<edition>.txt file from the disk, for example:

```
CPY OBJ('/QOPT/WEBSPPHERE/WAS/responsefile.base.txt') TODIR('/tmp')
```

**Note:** There is an additional prefix for the location of the installation files on DVD. It specifies the operating system.

In the example, *QOPT* is the disk mount point and *WEBSPPHERE* is the disk volume label.

6. If you have not already done so, read the IBM International Program License Agreement, which is located in the /QOPT/WEBSPPHERE/WAS/lafiles directory.
7. Edit the /tmp/responsefile.base.txt file using the EDTF command, for example:

```
EDTF STMF('/tmp/responsefile.base.txt')
```

See step 9 on page 49 for options descriptions.

8. Save the file by pressing F3 twice.
9. Open a Qshell session. On an i5/OS command line, type STRQSH.
10. Change the directory to the WAS subdirectory on the CD, for example:

```
CD /OPT/WEBSPPHERE/WAS
```

11. Invoke the install script, and point to your response file, for example:

```
install -options /tmp/responsefile.base.txt
```

If your system has little or no interactive features, use the following command:

```
SBMJOB CMD(STRQSH CMD('/QOPT/WEBSPPHERE/WAS/install -options  
/tmp/responsefile.base.txt')) JOB(INSTWAS) JOBQ(QSYSNOMAX) ALWMLTTHD(*YES)
```

12. After you invoke the installation script, messages are displayed that indicate the progress of the installation. When the setup program completes, check the last window. The last two messages should indicate the status of the installation: success, partial success, or failure, for example:

```
Process, com.ibm.ws.install.ni.ismp.actions.SetExitCodeAction, msg1,  
CWUPI0000I: EXIT-CODE=0  
Process, com.ibm.ws.install.ni.ismp.actions.ISMPLogSuccessMessageAction, msg1,  
INSTCONFSUCCESS
```

An exit code of 0 means successful installation.

13. You should also check the log file at:

```
<install_root>/logs/install/log.txt
```

## 3.5 Optional software components associated with WebSphere Application Server

There are additional software components that are supplied in the WebSphere Application Server package. These are some of the more important components:

▶ WebSphere plug-ins

Only required if you install your Web server on a different machine or partition from a WebSphere Application Server location. See 5.3, “Configuring a remote Web server with WebSphere Application Server” on page 171 for more information about installing the plug-in.

▶ Application Clients.

Tools that provide a stand alone client run-time environment to enable client applications to communicate with WebSphere Application Server.

▶ Application Server Toolkit

A development tool for creating and testing Web applications. It is supported on Windows or Linux®.

▶ IBM Update Installer

Installs updates to your WebSphere Application Server environment. See 3.6.2, “Installing the Update Installer” on page 54.

▶ IBM Installation Factory

This is a new tool to package WebSphere Application Server fixes, applications, and other components in a single installable pack. See 3.8, “IBM Installation Factory” on page 61.

▶ IBM Support Assistant

This tool centralizes access to help, support, and other tools in one interactive application. See Appendix C, “IBM Support Assistant” on page 421.

Installation of the additional software is out of the scope of this book. See the Information Center for more information:

<http://publib.boulder.ibm.com/infocenter/wasinfo/v6r1/index.jsp>

## 3.6 Installing the latest recommended WebSphere Application Server fixes

After you install WebSphere Application Server V6.1 from CD or DVD media, we recommend that you apply the latest available WebSphere Application Server fixes before you start WebSphere Application Server for the first time.

Fixes for WebSphere Application Server V6.1 for i5/OS are delivered through a fix pack that is included in the WebSphere Application Server for i5/OS group PTF. The group PTF numbers for all WebSphere Application Server V6.1 products for i5/OS releases V5R3M0/V5R3M5 and V5R4M0 are, SF99322 and SF99323 respectively.

In WebSphere Application Server V5.0 and earlier versions, the WebSphere Application Server fix packs were installed during the installation of the WebSphere Application Server group PTF without user intervention. However starting with V6, applying WebSphere Application Server fix packs is now a two-stage process:

1. Install the WebSphere Group PTF using the standard group PTF installation procedures.
2. Use the Update Installer software to apply the WebSphere Application Server fix pack. See 3.6.2, “Installing the Update Installer” on page 54 for information about Update Installer.

During the WebSphere group PTF installation in step 1, the WebSphere Application Server fix pack is automatically placed under the V6.1 Update Installer directory. You must then run the update script to actually install the fix pack, as described in 3.6.3, “Applying WebSphere Application Server fixes” on page 54.

### 3.6.1 Installing the WebSphere Group PTF

The WebSphere Application Server V6.1 group PTF includes the following group PTFs:

- ▶ WebSphere Application Server V6.1
- ▶ DB2 UDB for iSeries
- ▶ Java
- ▶ IBM HTTP Server for i5/OS

The WAS Group PTF numbers are as follows:

- ▶ SF99322 for V5R3M0 / V5R3M5
- ▶ SF99323 for V5R4M0

For details about the latest WebSphere Application Server group PTF level, check the Web site at:

[http://www-912.ibm.com/s\\_dir/sline003.nsf/GroupPTFs?OpenView&view=GroupPTFs](http://www-912.ibm.com/s_dir/sline003.nsf/GroupPTFs?OpenView&view=GroupPTFs)

Use the instructions that are shipped with your package to install the WebSphere Application Server group PTF.

For information about the release as well as descriptions of known problems and workarounds, see the WebSphere Application Server support Web site at:

<http://www-1.ibm.com/support/search.wss?rs=180&tc=SSEQTP&atrn=SWPlatform&atrv=i5/OS&q=V61RNotes>

## 3.6.2 Installing the Update Installer

The Update Installer is the tool that applies the WebSphere Application Server fixes. It is installed during Group PTF installation. However, you can download and install this tool separately from the following Web site, which also includes installation instructions:

<http://www-1.ibm.com/support/docview.wss?rs=180&uid=swg24012718>

**Note:** Only one Update Installer installation is allowed in i5/OS. All WebSphere Application Server installations share the same Update Installer binaries. You must uninstall Update Installer before you install a new one.

Update Installer is by default installed under the following directory:

```
/QIBM/ProdData/WebSphere/UpdateInstaller/V61/UPDI
```

You can change the default path during the installation process.

## 3.6.3 Applying WebSphere Application Server fixes

Starting from WebSphere Application Server V6.0, the WebSphere fixes are usually installed and applied in a two-step process:

- ▶ Install a WebSphere group PTF using i5/OS native PTF process.
- ▶ Apply WebSphere fixes using the Update Installer.

In addition to applying fixes that come in a WebSphere group PTF, you can search, download, and install individual fixes without waiting for the group PTF. See “Installing individual fixes” on page 414 for more information.

Perform the following instructions to apply WebSphere Application Server fixes:

1. Sign on to your System i server with a user ID that has \*ALLOBJ authority.
2. Stop all Java processes that use the WebSphere Application Server product you are updating. These processes include all application server processes, the node agent process, the deployment manager process, and any WebSphere Application Server client applications.
3. Start hosts servers. On an i5/OS command line, type STRHOSTSVR SERVER(\*ALL), and press Enter.
4. Open a QShell session by typing STRQSH.
5. Go to your Update Installer directory, for example:

```
cd /QIBM/ProdData/WebSphere/UpdateInstaller/V61/UPDI
```

After you install the Group PTF, the latest fixes are copied into the maintenance directory of your Update Installer folder. The default directory for the maintenance packages is:

```
/QIBM/ProdData/WebSphere/UpdateInstaller/V61/UPDI/maintenance
```

The fixes are packed as the .pak files.

**Attention:** Installing the Group PTF only updates the Update Installer folder. It does not apply the WAS fixes.

6. Execute the update script:

```
update -W product.location=<WAS_install_root>
```

Example:

```
update -W product.location=/QIBM/ProdData/WebSphere/AppServer/V61/Base/
```

The update script checks the maintenance folder and applies all new fixes that it finds in that folder. If you want to install a very specific fix, use an additional command line argument, for example (one line command):

```
update
  -W product.location=/QIBM/ProdData/WebSphere/AppServer/V61/Base/
  -W maintenance.package="maintenance/6.1.0-WS-WAS-i5osPPC-FP0000007.pak"
```

**Important:** If you have multiple installations, you have to run the update script for each installation by replacing <installRoot> with each installation's root directory.

7. Do not exit your QShell session until the update process ends. At the end of the script execution (Figure 3-17 on page 56) the following messages are displayed:

```
com.ibm.ws.install.ni.ismp.actions.ISMPLogSuccessMessageAction, msg1,
INSTCONFSUCCESS
Wizard.getExitCode(): called after WizardServices is shutdown.
Wizard.getExitCode(): called after WizardServices is shutdown.
```

Figure 3-17 on page 56 is an example of the update script.

**Attention:** WebSphere Application Server fix pack installation is a long procedure. It can take several hours on small systems or partitions.

```
QSH Command Entry

Current install/uninstall process is successful. Processtype is: maintenance
(Aug 11, 2006 3:17:19 PM), Install, com.ibm.ws.install.ni.ismp.actions.Settle
NIFRegistryAction, msg1, Current install/uninstall process is successful.
Process type is: maintenance
I      CWUPI0000I: EXITCODE=0
(Aug 11, 2006 3:17:19 PM), Install,
com.ibm.ws.install.ni.ismp.actions.SetExitCodeAction, msg1, CWUPI0000I: EXITCODE=0
I      INSTCONFSUCCESS
(Aug 11, 2006 3:17:19 PM), Install,
com.ibm.ws.install.ni.ismp.actions.ISMPLo
gSuccessMessageAction, msg1, INSTCONFSUCCESS
Wizard.getExitCode(): called after WizardServices is shutdown.
Wizard.getExitCode(): called after WizardServices is shutdown.
$

====>

F3=Exit   F6=Print F9=Retrieve F12=Disconnect
F13=Clear F17=Top  F18=Bottom F21=CL command entry
```

Figure 3-17 Fixpack installation

- 8. You can also check the log file under one of the directories under the *update* folder, for example:

<WAS\_install\_root>/logs/update/6.1.0-WAS-WAS-i5osPPC-FP0000007.install/

The name of the directory correlates with the name of the WebSphere Application Server fix pack that is being applied.

### 3.7 Performing post installation tasks

The following tasks must be completed before you start your WebSphere Application Server for the first time.

**Tip:** Before you perform the post-installation tasks that we describe in this section, we recommend that you first install the latest WebSphere Application Server V6.1 fix pack. See 3.6, “Installing the latest recommended WebSphere Application Server fixes” on page 53 for more information.

#### 3.7.1 Entering license information

This procedure only applies to Base and Network Deployment installations. You do not need to configure the license for the Express product:

1. Start a 5250 emulator session and sign on.
2. In a command line, type WRKLCINF.

3. Press **F11** to see the usage limit.
4. Enter option 2 next to your product entry:
  - WebSphere Application Server Base 5722W61 option 5102
  - WebSphere Application Server Network Deployment option 5103
5. Enter the appropriate value for the number of processors that are licensed according to your proof of entitlement.
6. Press F9 for additional parameters.
7. Specify \*USGLMT for the Threshold parameter. This must not be 0. If you skip this step, warning messages appear in the job log of the server.
8. Press Enter.

### 3.7.2 Verifying TCP/IP configuration

You can verify your TCP/IP configuration running the iptest script:

1. Start a 5250 emulator session and sign on.
2. Open a QShell session.  
STRQSH
3. Switch to the bin directory of the WebSphere installation root, for example:  
cd /QIBM/ProdData/WebSphere/AppServer/V61/Base/bin
4. Run the script iptest. Make sure that the script returns a valid IP address and host name. Figure 3-18 shows sample output.

```

                                QSH Command Entry

$
> cd /QIBM/ProdData/WebSphere/AppServer/V61/Base/bin
$
> iptest
Local Address: 192.168.9.2
Local Name: RCHAS07.JALCUDIA.COM
All addresses for RCHAS07.JALCUDIA.COM:
    192.168.9.2

$
===>

F3=Exit  F6=Print  F9=Retrieve  F12=Disconnect
F13=Clear  F17=Top  F18=Bottom  F21=CL command entry

```

Figure 3-18 iptest output

### 3.7.3 Verifying the installation directories

In WebSphere Application Server V6.1, you can perform multiple installations of the product. To view information about these installation, WebSphere Application Server V6.1 provides several QShell scripts that are located in the /QIBM/WAS/bin/ directory.

To get information about all of the installations on the system, run the following script from a QShell command line:

```
/QIBM/WAS/bin/querywasinstalls
```

In Figure 3-19, you can see an example of the command output. As you can see, this script displays information about different versions of WebSphere Application Server that are installed on the system. The script shows information about product and profiles installation directories, as well as the fix level of the installed product, for example:

```
Version:                6.1.0.7
```

This is one of the ways to check your WebSphere fix level.

```
QSH Command Entry

$
> /qibm/was/bin/querywasinstalls
-----
Offering ID:      Base
Version:         5.0
Installation Location: /QIBM/ProdData/WebAS5/Base
Installation Library: QEJBAS5
Default Profile Location: /QIBM/UserData/WebAS5/Base
-----
Offering ID:      BASE
Version:         6.1.0.7
Installation Location: /QIBM/ProdData/WebSphere/AppServer/V61/Base
Installation Library: QWAS61B
Default Profile Location: /QIBM/UserData/WebSphere/AppServer/V61/Base
-----
Total: 2 products installed.
$

===>

F3=Exit F6=Print F9=Retrieve F12=Disconnect
F13=Clear F17=Top F18=Bottom F21=CL command entry
```

Figure 3-19 querywasinstalls output

### 3.7.4 Configuring SQL jobs

Perform this configuration task after you install and start your production applications. If you are using a JDBC driver to access the i5/OS database from your applications, you might need to change the initial and maximum number of prestart jobs. Each JDBC connection object requires one SQL server job.

There are two main JDBC drivers supported for DB2 UDB for i5/OS:

- ▶ A JDBC driver in the IBM Developer Kit for Java, which is also known as the “native” driver. This driver uses the QSQSRVR SQL job to access the database.
- ▶ A JDBC driver in the IBM Toolbox for Java. This driver uses the QZDASOINIT SQL job to access the database.

Use the following steps to properly set the number of prestart jobs. The process is almost identical for both SQL jobs. We demonstrate how to do it for the QSQRVR job:

1. Start a 5250 emulator session and sign on.
2. During a period of peak load on the server, display the current active prestart jobs in your system with the Display Active Prestart Jobs (DSPACTPJ) command:

```
DSPACTPJ SBS(QSYSWRK) PGM(QSQRVR)
```

Figure 3-20 shows the output of the DSPACTPJ command.

```

                                Display Active Prestart Jobs                                RCHAS07
                                                                                   08/15/07 09:32:48
Subsystem . . . . . : QSYSWRK           Reset date . . . . . : 08/04/07
Program . . . . . : QSQRVR             Reset time . . . . . : 16:28:53
Library . . . . . : QSYS               Elapsed time . . . . . : 0257:03:55

Prestart jobs:
Current number . . . . . : 11
Average number . . . . . : 11.0
Peak number . . . . . : 11

Prestart jobs in use:
Current number . . . . . : 9
Average number . . . . . : 9.0
Peak number . . . . . : 9

                                                                                   More...

Press Enter to continue.

F3=Exit  F5=Refresh  F12=Cancel  F13=Reset statistics

```

Figure 3-20 Display Active Prestart Jobs

3. Calculate the recommended *initial* number of jobs. Add to the Average number 15% more jobs (*must* be an integer number). In this case:

$$9 * 1,15 = 10,35.$$

We round up to 11.

4. If appropriate, set the maximum number of prestarted jobs to \*NOMAX. Otherwise, set it to the number considerably above the number that you calculated in the previous step.

Use the Change Prestart Job Entry (CHGPJE) command to change the prestart job entry for the SQL server jobs.

```
CHGPJE SBS(QSYSWRK) PGM(QSQRVR) INLJOBS(11) MAXJOBS(*NOMAX)
```

5. After you run the command, the following message is displayed:

```

Program QSQRVR found in library QSYS.
Active subsystem description QSYSWRK in QSYS changed.

```

### 3.7.5 Verifying WebSphere Application Server installation

It is now time to start the server and verify that it works correctly. Execute the *ivt* script to verify your installation. The *ivt* script is placed under your <install directory> /bin directory, for example:

```
/QIBM/ProdData/WebSphere/AppServer/V61/Base/bin
```

To run the script, perform the following steps:

1. Start a 5250 emulator session and sign on.
2. Start QShell with the following command:

```
STRQSH
```

3. Go to the bin directory of your installation, for example:

```
cd /QIBM/ProdData/WebSphere/AppServer/V61/Base/bin
```

4. Execute the *ivt* script:

```
ivt <server> <profile>
```

Example: `ivt server1 default`

Figure 3-21 shows the output you should see. If it returns any error, investigate the problem. See 3.9, “Troubleshooting the WebSphere Application Server 6.1 installation” on page 77 for more information.

```
QSH Command Entry

t/ivtserver?parm2=ivtejb
IVTL0060I: Enterprise bean verification status: Passed
IVTL0035I: The Installation Verification Tool is scanning the file/QIBM/User
Data/WebSphere/AppServer/V61/jalculdia/profiles/default/logs/server1/SystemOut
.log for errors and warnings.
[8/8/06 16:48:00:839 UTC] 0000000a WSKeyStore W CWPKI0041W: One or more
key stores are using the default password.
[8/8/06 16:51:35:923 UTC] 0000000a ThreadPoolMgr W WSVR0626W: The
ThreadPoo
l setting on the ObjectRequestBroker service is deprecated.
IVTL0040I: 2 errors/warnings are detected in the file
/QIBM/UserData/WebSpher
e/AppServer/V61/jalculdia/profiles/default/logs/server1/SystemOut.log
IVTL0070I: The Installation Verification Tool verification succeeded.
IVTL0080I: The installation verification is complete.
$

===>

F3=Exit F6=Print F9=Retrieve F12=Disconnect
F13=Clear F17=Top F18=Bottom F21=CL command entry
```

Figure 3-21 Output of the *ivt* script

## 3.8 IBM Installation Factory

IBM Installation Factory enables you to create your own WebSphere Application Server installation image that can include one or more maintenance packages, a configuration archive from a stand-alone application server profile, one or more enterprise archive files (EAR) and scripts, and other files that help customize the resulting installation. The result of this operation is a Customized Installation Package (CIP).

You can also use the IBM Installation Factory to upgrade an existing installation of WebSphere Application Server. In the example in Figure 3-22, a CIP contains WebSphere Application Server V6.1, the V6.1.x.z maintenance package, an upgrade for the Java SDK, and two interim fixes 'A' and 'B'. When this custom install package is installed on the various systems shown on the right, they are upgraded to the same maintenance level as the custom install package. The chart illustrates that the custom installer only installs the missing software and fixes.

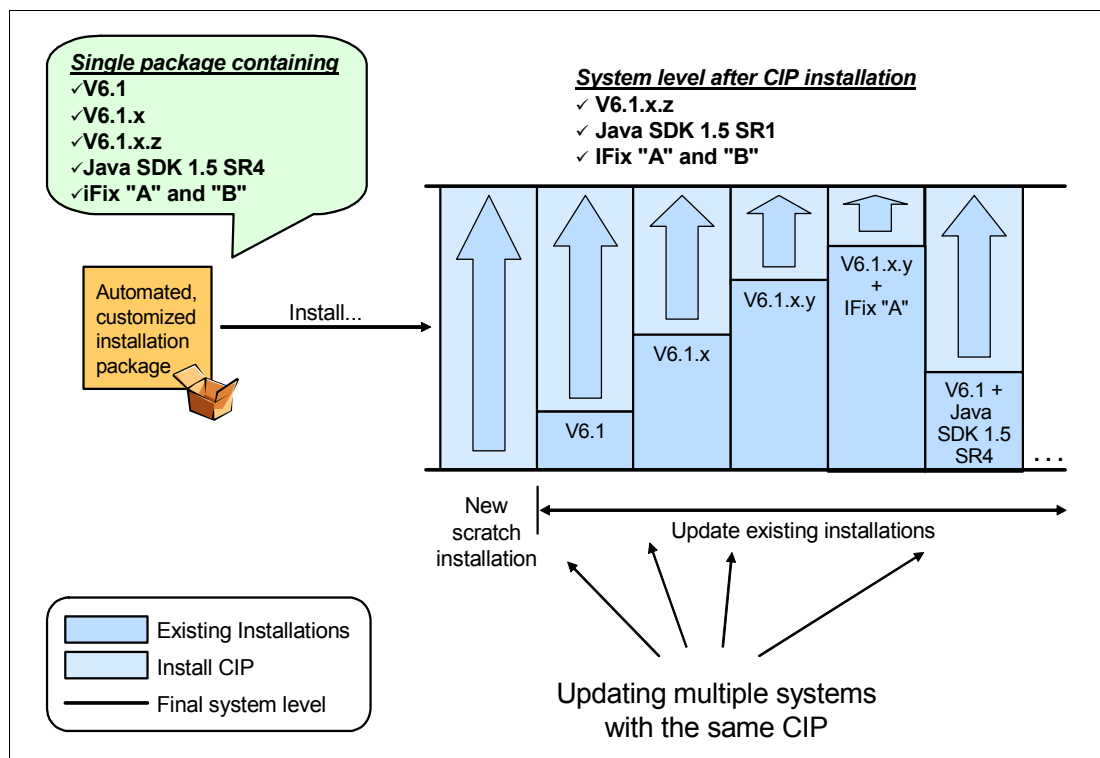

Figure 3-22 Using IBM Installation Factory to update existing WAS installations

**Restriction:** Remote installation from a Windows workstation using a CIP is only supported when you perform a scratch installation of a CIP with no interim fixes. In all other cases, you need to apply the CIP locally on the System i server.

### 3.8.1 Installing IBM Installation Factory

You can install Installation Factory from the Tools CD that shipped with WebSphere Application Server, or you can download it from the IBM Installation Factory page:

<http://www-1.ibm.com/support/docview.wss?rs=180&uid=swg24012817>

To install IBM Installation Factory from a CD:

1. Insert the Tools CD in to your workstation CD drive.
2. From a command prompt, change to the Installation Factory install directory of the CD by issuing the following two commands (assuming that your CD drive letter is D):

```
D:  
cd D:\InstallationFactory
```

3. Type the **setupif.batg** command, and press Enter:

This script copies Installation Factory and the Java Runtime Environment (JRE) from the CD to the workstation under the C:\InstallationFactory directory.

### 3.8.2 Using IBM Installation Factory

The first step in creating a CIP is to create a *build definition*. A build definition is an XML document that defines the parameters for the custom install you are creating.

1. The easiest way to create a CIP is to execute the **ifgui** command. You can find this command in the <install\_dir>\InstallationFactory\bin directory. When the window (Figure 3-23) displays, click **Create New Customized Installation Package** to create a new CIP.



Figure 3-23 IBM Installation Factory welcome panel

- In the next panel (Figure 3-24), choose the product that you want to install using IBM Installation Factory. Choose **IBM WebSphere Application Server 6.1.0.0, WebSphere Application Server** in the Product packages panel, and, for example, **Base**. Click **Finish**.

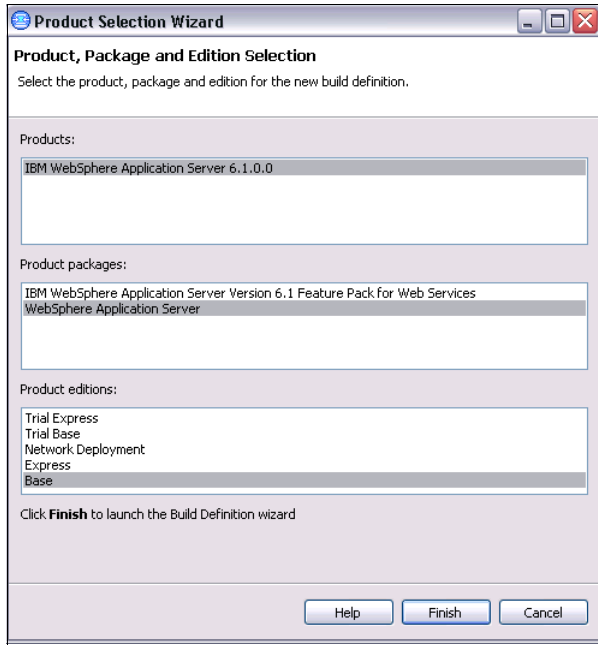

Figure 3-24 IBM Installation Factory-Product selection

- When the Mode Selection window (Figure 3-25) appears, choose the **Connected Mode** option and **i5/OS** to create the CIP in your workstation.

Use disconnected mode if you only want to create the build definition file (no binaries included). In this case, instead of choosing a local directory on your workstation, you choose the path that corresponds to the target platform. See explanation for the Disconnected mode in the panel.

Click **Next**.

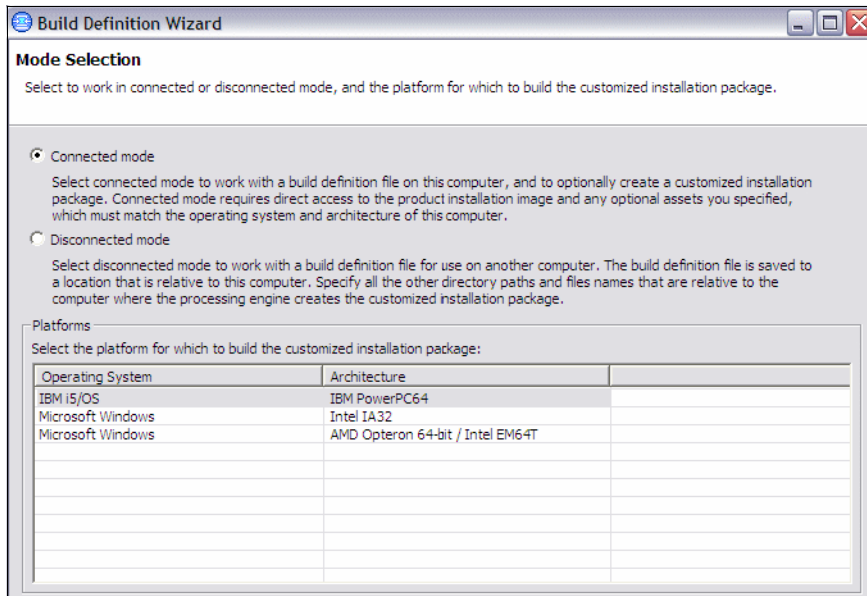

Figure 3-25 IBM Installation Factory-Mode selection

4. In the Package Information panel (Figure 3-26), enter a name to identify your CIP and a version number. The name and version creates a full package identifier that the install process uses later. The convention when choosing a name is to use a reverse domain naming schema followed by your company, division, and product name, for example, in our case it is com.ibm.itso.was61residency. Click **Next**.

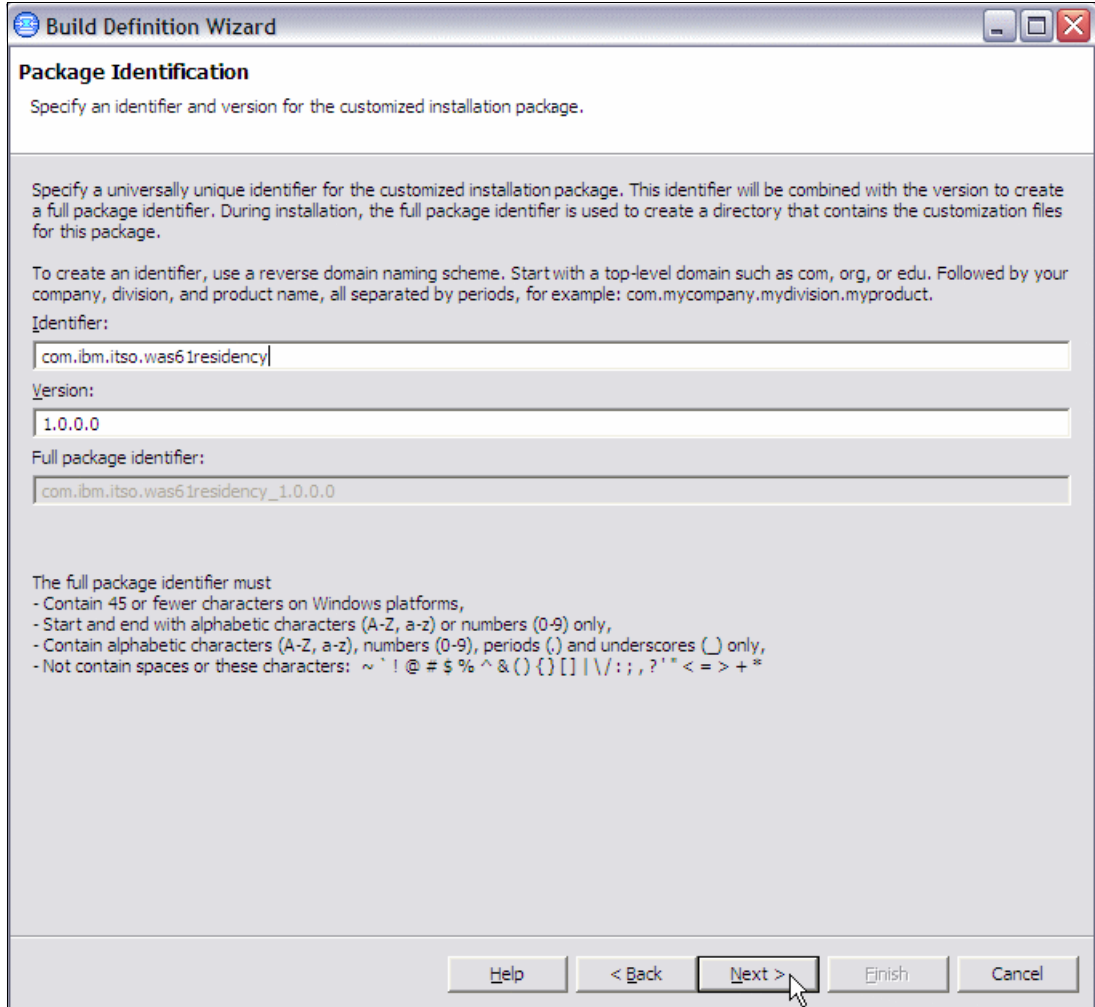

Figure 3-26 IBM Installation factory-Package identification

5. The Build Information (Figure 3-27) panel allows you to choose the path where the CIP and the build definition will be stored. Choose your preferred location, and click **Next**.

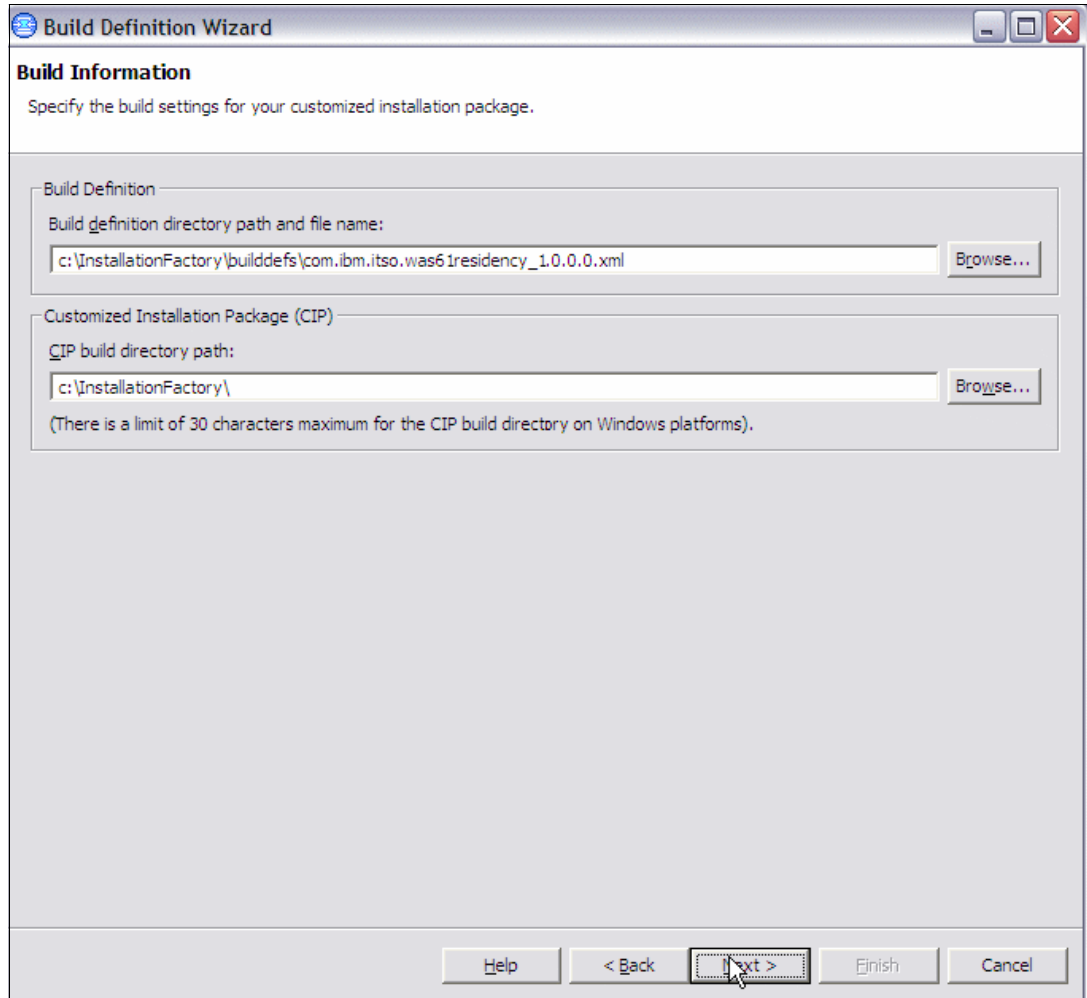

Figure 3-27 Installation Factory-Build information

6. In the Product Installation Image panel (Figure 3-28), you *must* select the source (WAS directory) of your installation. Usually it will be a directory of your CD drive, by default:

<driver letter>:\WAS

Remember that this must be the WAS directory that corresponds to the same edition that you selected in the Edition Selection panel, as shown in Figure 3-24 on page 63. Choose the path, and click **Next**.

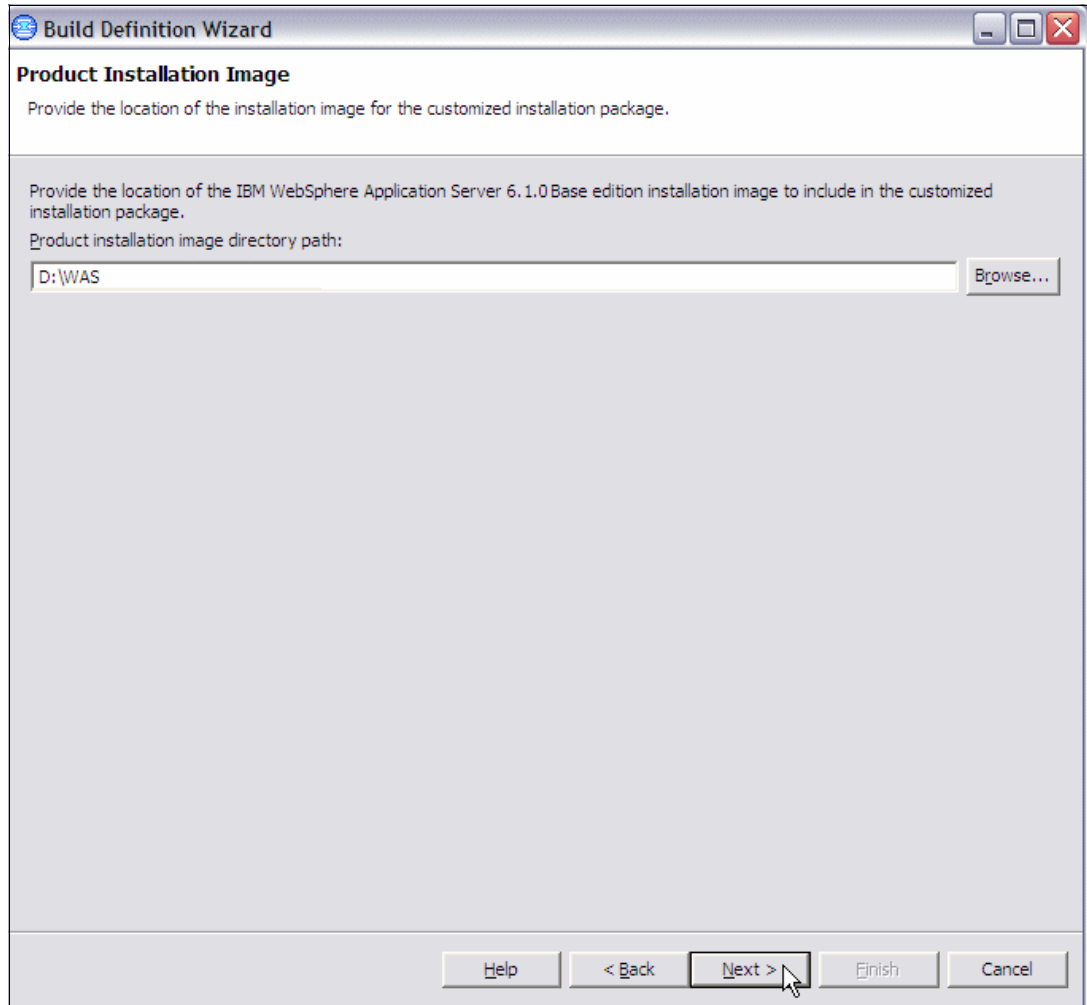

Figure 3-28 IBM Installation Factory-Product installation image

7. The Feature Selection panel (Figure 3-29) allows you to select the installation options for your WebSphere Application Server environment. The only option to select is if you want to install the samples or not. Make your selection, and click **Next**.

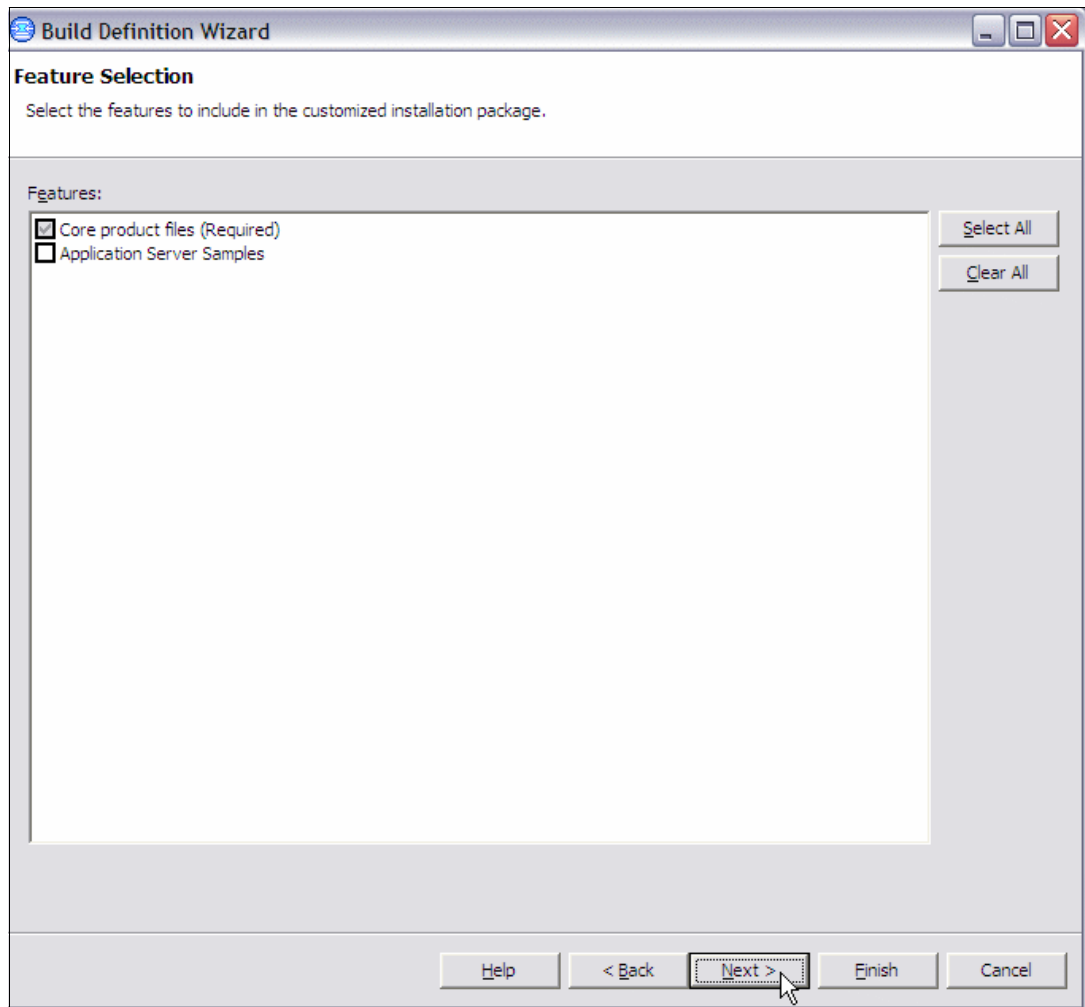

Figure 3-29 Installation Factory-Installation options

8. Figure 3-30 on page 68 shows the Maintenance Packages panel, where you perform the following steps:
  - a. Point to the location of a .pak file, if needed, for WebSphere Application Server fixes to be installed.
  - b. Select the fixes you need for your custom install. You can choose to install fix packs or individual fixes. See 3.6.3, “Applying WebSphere Application Server fixes” on page 54 for information about the different types of fixes.
  - c. Press **Verify Maintenance Packages** to be sure that the fix packs are not corrupt. When the *The verification is successful!* message appears at the top of the panel, press **Next**.

The *SDK fix pack* field installs the Java SDK fixes. For i5/OS, you install the Java SDK fixes by loading and applying the Java group or single PTFs using the native PTF installation process.

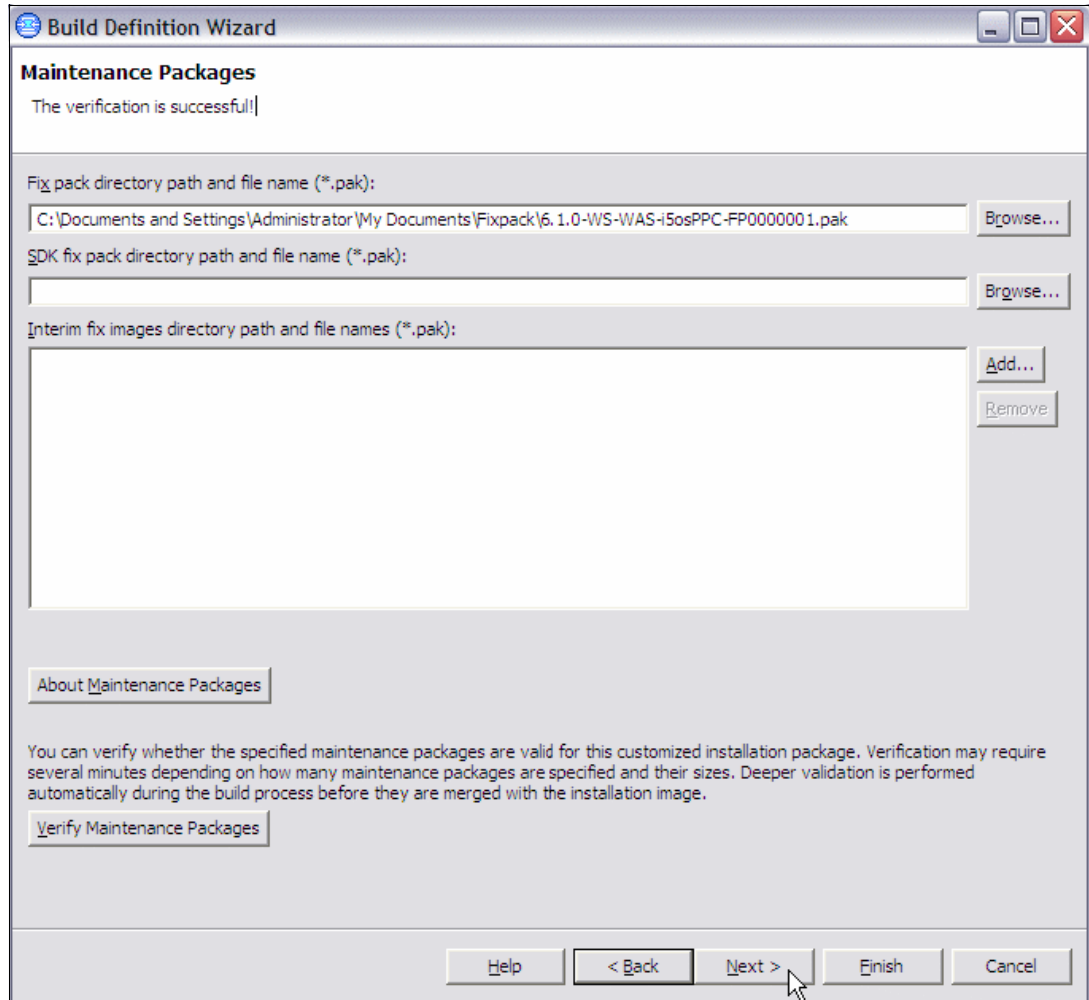

Figure 3-30 Installation Factory-Maintenance Packages panel



10. Use the Add Script panel (Figure 3-32) to locate the file that contains the script. You can configure the installer to stop if the script execution fails by selecting **Stop the operation if an error occurs while running this script**. Press **OK**.

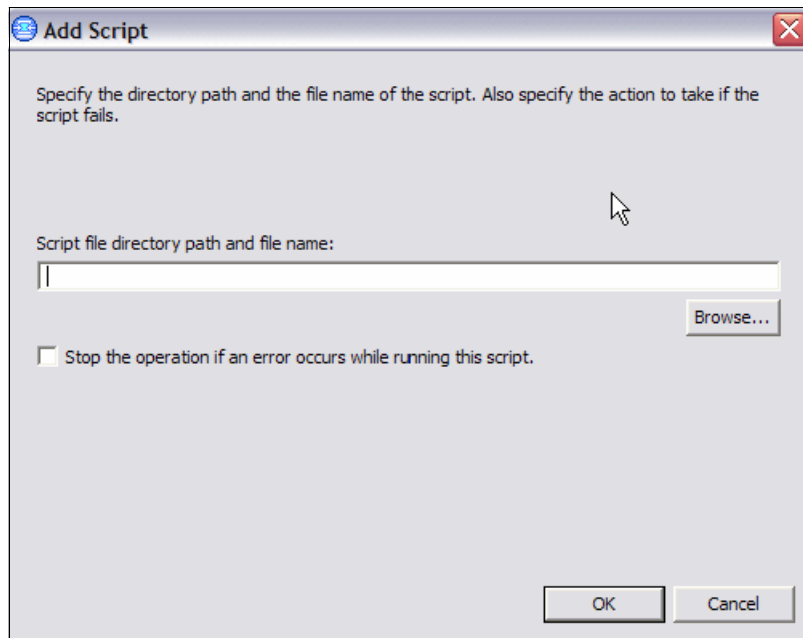

Figure 3-32 Installation Factory-Add script

11. Add more scripts if necessary.

**Note:** You can add scripts if your application needs further configuration after the install, for example, a database connection. These scripts only run if you are performing a new installation. If you use Installation Factory to update an existing installation, these scripts do not run.

12. Choose the order of your scripts using **Move Up** and **Move Down** in the Install and Uninstall panel (Figure 3-31 on page 69), and press **Next**.

13. In Figure 3-33, you see the Profile Customization Panel, where you can add profile creation scripts, enterprise archives, and configuration archives. In this case, we decide to add an enterprise archive to install a custom application. Press the **Add Enterprise Archive** button.

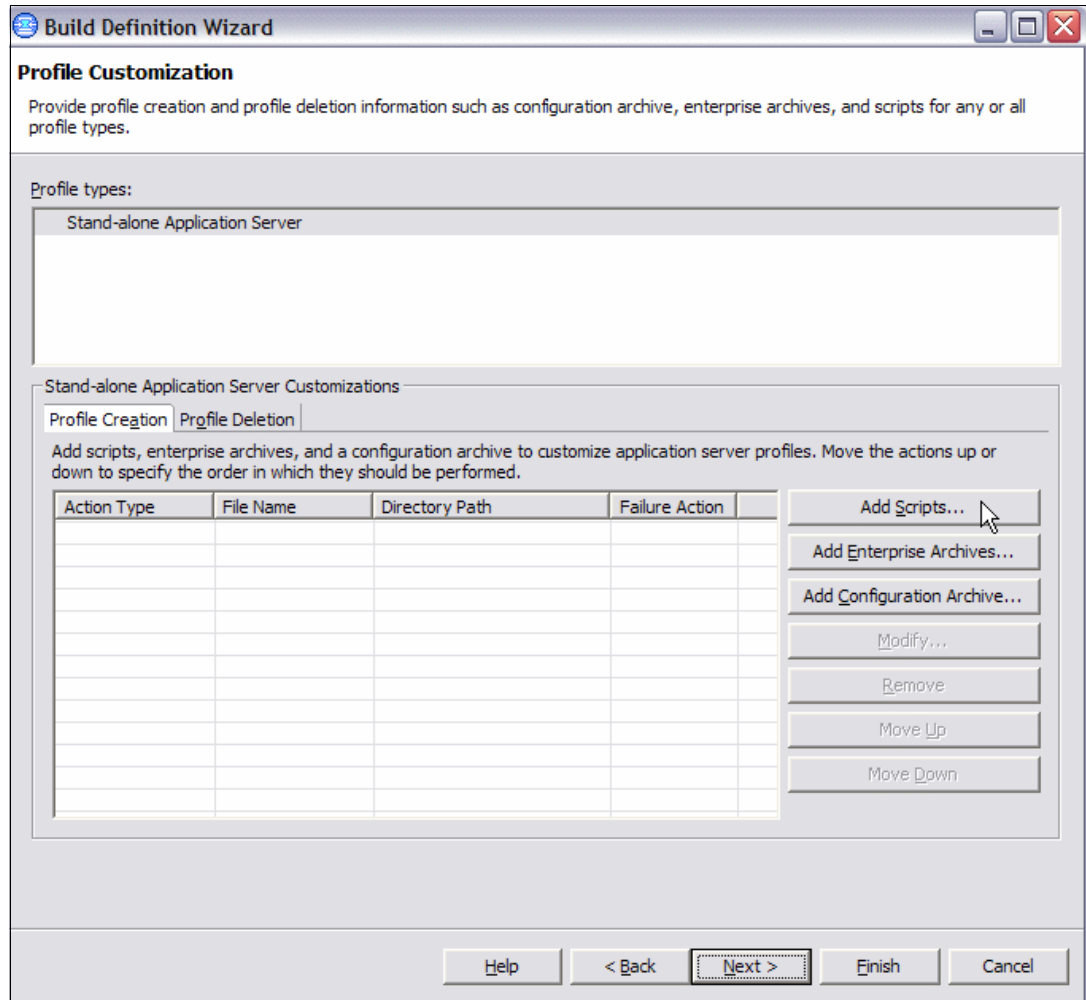

Figure 3-33 Installation Factory-Profile customization

14. Figure 3-34 shows the Add an Enterprise Archive (EAR) panel. Locate the EAR file, and press **OK** to return to the Profile Customization Panel.

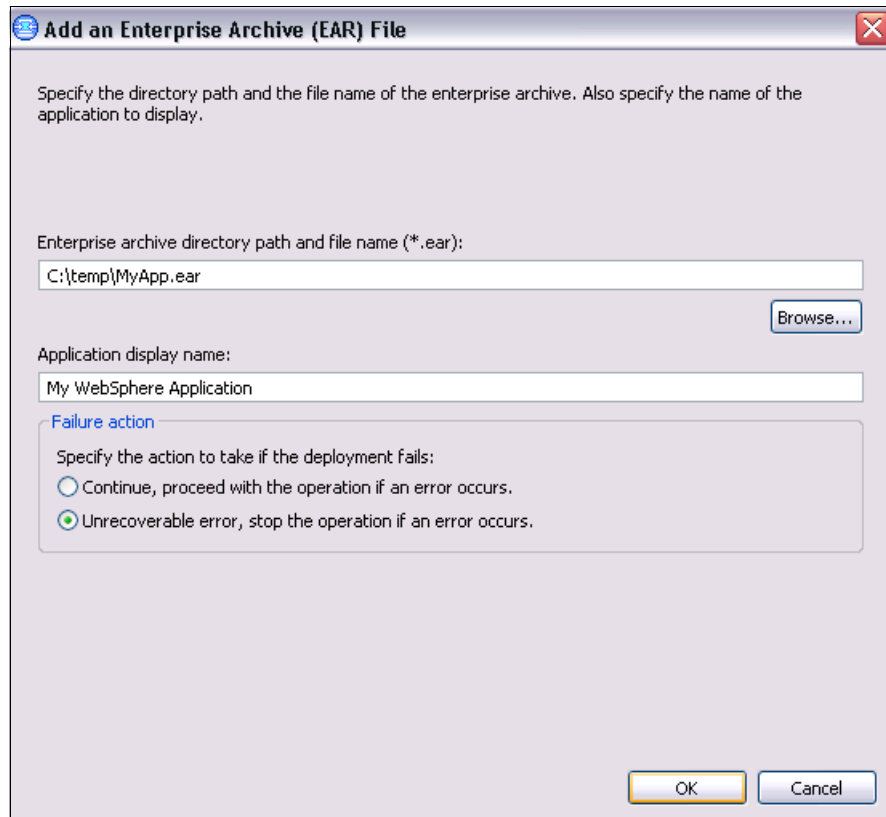

Figure 3-34 Installation Factory-Add an Enterprise Archive (EAR) file

**Tip:** Modify your Application Deployment Descriptor to configure resources needed, such as JDBC providers and datasources.

- The application you selected is added to the Profile Customization Screen (Figure 3-35). You can now add more EAR files, scripts to configure your profile, or configuration archives. Add the files you need, and press **Next**.

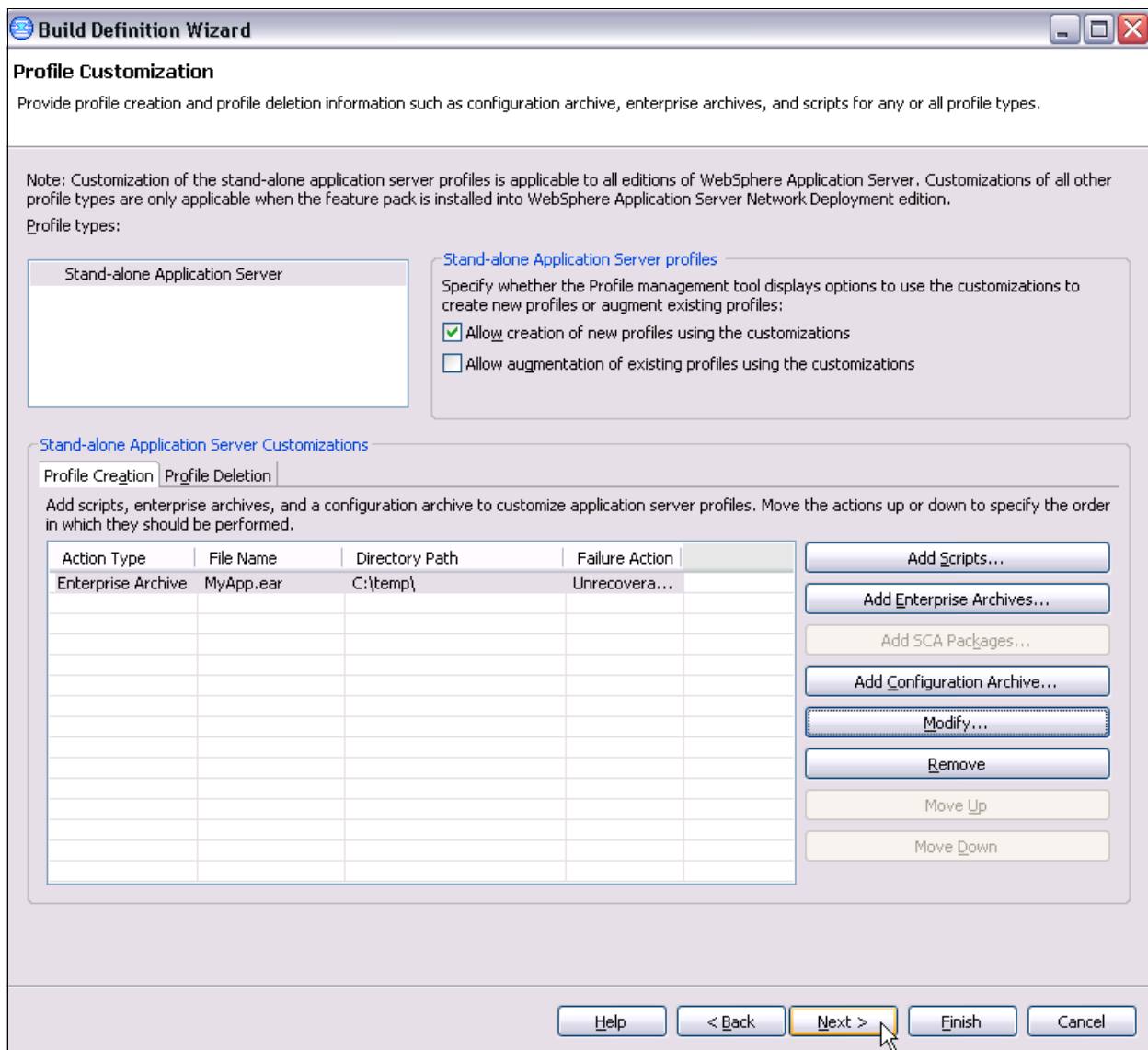

Figure 3-35 Installation Factory-Profile Customization with application selected

16. Figure 3-36 shows the Additional Files panel. In this panel, you can add additional files to the CIP, for example, a folder with pictures or an additional help system that you want to add to your HTTP server directory. Select files or directories as needed, and click **Next**.

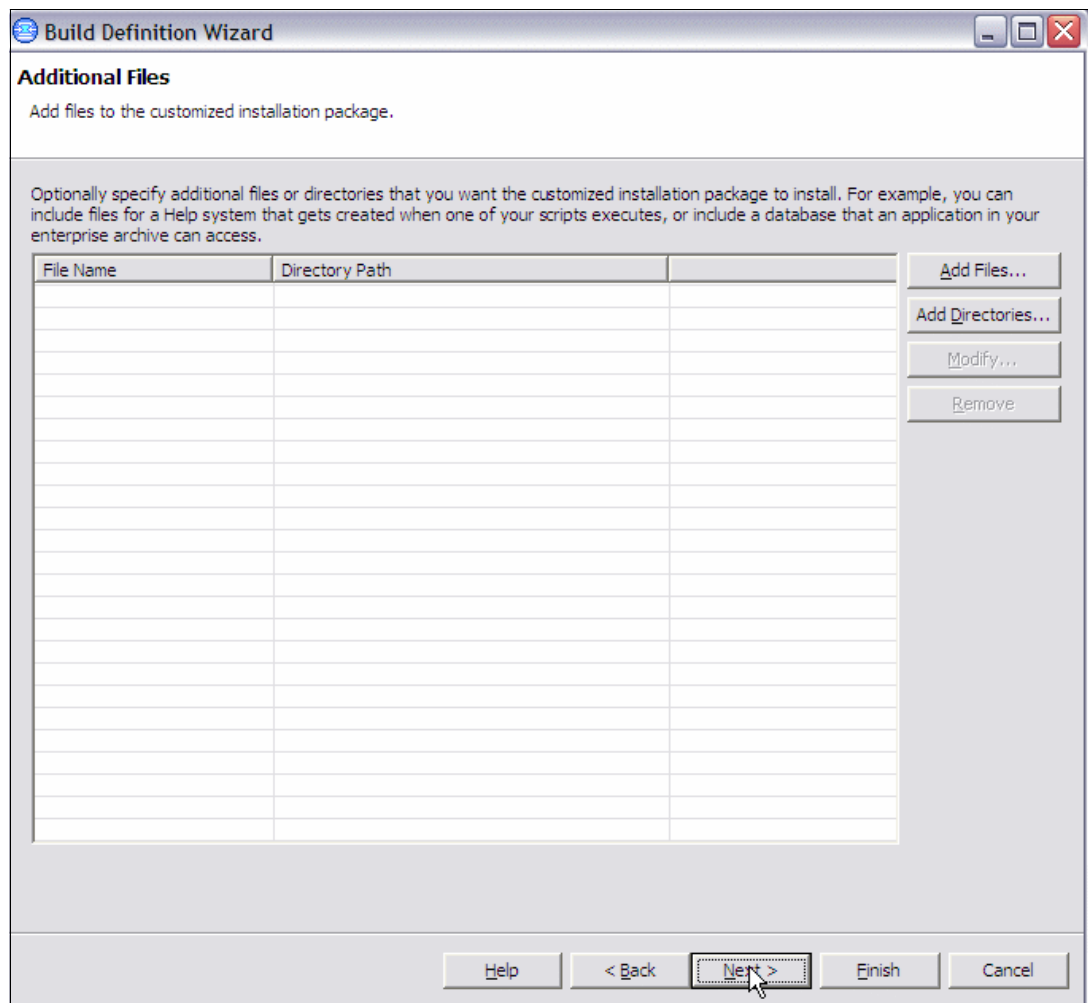

Figure 3-36 Installation Factory-Additional files

17. The last configuration step is to sign your work in the Authorship panel (Figure 3-37). The resulting panel is displayed when you press **About this customized installation** in the installation package. Enter your data, and click **Next**.

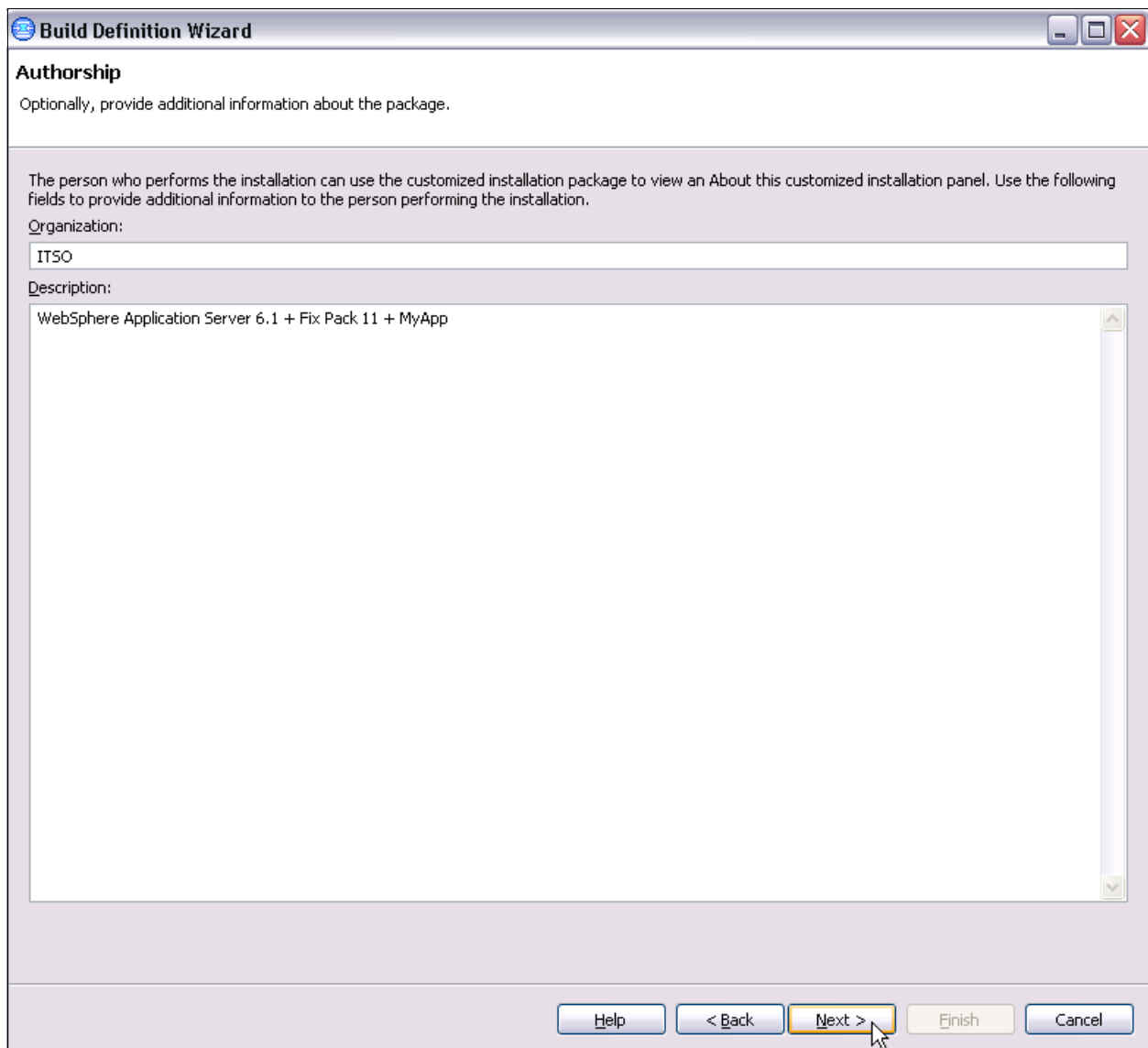

Figure 3-37 Installation Factory. Authorship.

18. In the Customized Installation Package Preview panel (Figure 3-38 on page 76), you can choose between generating only the definition file or generating the full customized installation package.

**Tip:** You can also select **Estimate Size and Available Space** to ensure that your hard drive has sufficient space for the package.

Select the option you want, and press **Finish**.

If you do not want to generate the customized installation package at this time, you can always execute the `ifgui` command again, and select **Create New Customized Installation Package**, as shown in the Welcome panel in Figure 3-23 on page 62.

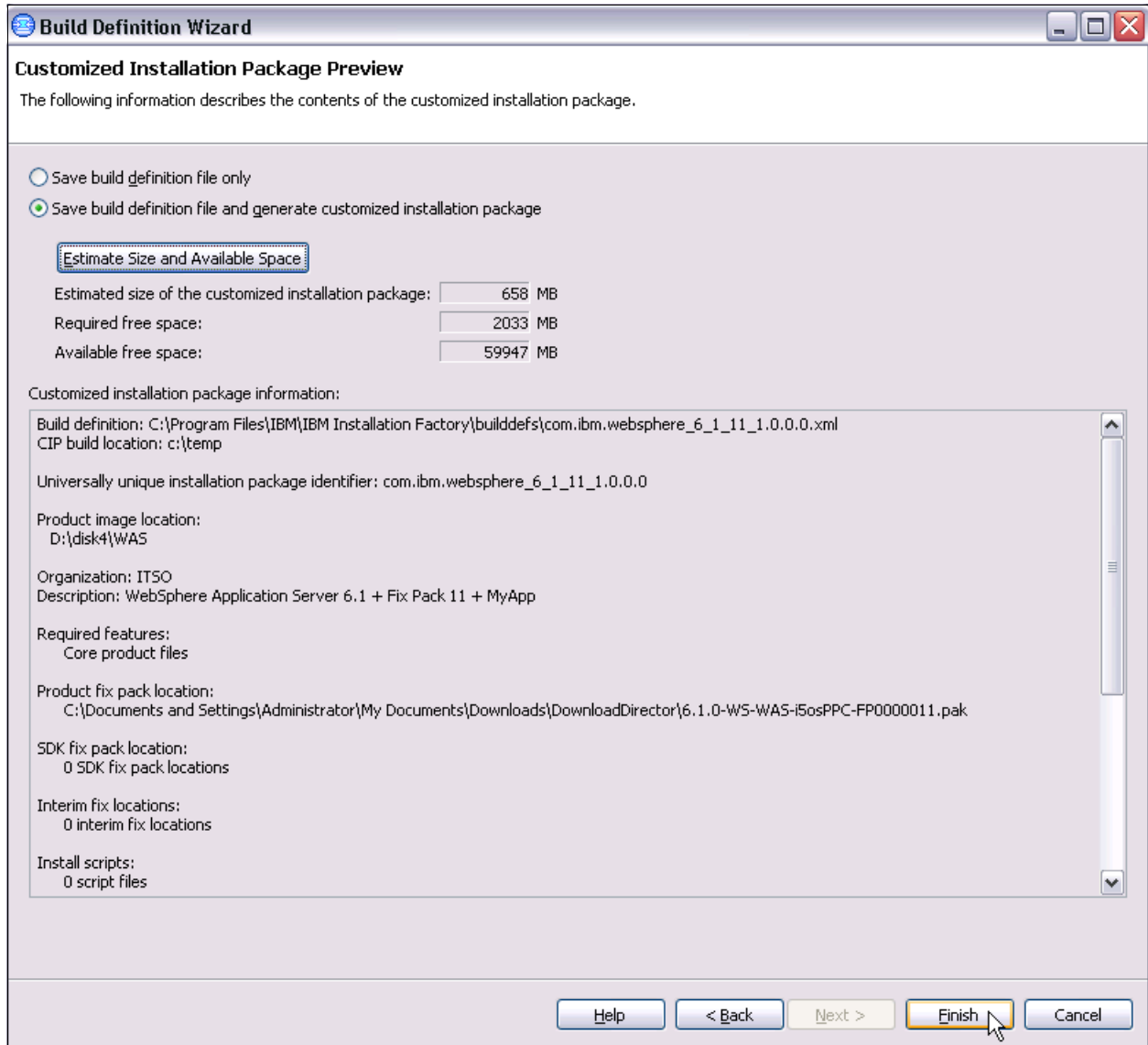

Figure 3-38 Installation Factory. Customized Installation Package preview.

### Generating the Customized Installation Package (CIP)

If you select to generate the customized installation package, the Installation wizard creates a directory with all of the components. Installation Factory generates the CIP under the Installation Factory directory on your workstation, in a directory called ifpackage. The default path is C:\InstallationFactory\ifpackage.

If the build definition file or the directory exists, you are prompted to change the path.

When Installation Factory ends, the successful build panel appears (Figure 3-39 on page 77). In this panel, you can see the path for the build definition file and the CIP. Press **OK** to exit the wizard.

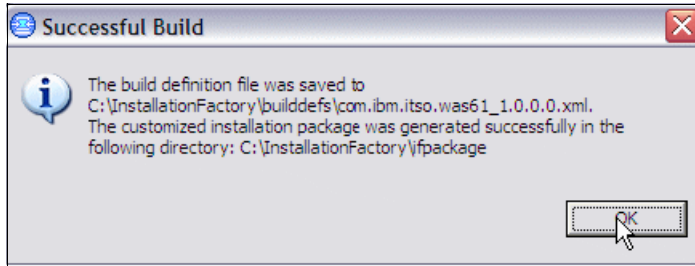

Figure 3-39 Installation factory-Successful build

You can now copy the content of the C:\InstallationFactory\ifpackage directory to a CD/DVD or IFS of your i5/OS server. You are ready to install your CIP.

### Installing a CIP in i5/OS

Installing a CIP is similar to the local silent installation that we described in “Local silent installation” on page 51. One additional thing that you have to keep in mind is that there are additional parameters in the response file that you might need to set specifically for the CIP installation, for example, if you install your CIP on top of the existing WebSphere Application Server installation, then you have to uncomment or set additional parameters. See comments for the parameters in the response file.

## 3.9 Troubleshooting the WebSphere Application Server 6.1 installation

In this section, we describe how to troubleshoot the most common problems you can encounter during your WebSphere Application Server V6.1 installation and the content of the install log files.

### 3.9.1 Connection failed

If the message in Figure 3-40 appears, check that your hosts servers are started.



Figure 3-40 Connection refused window

If the hosts servers are started, verify that you can ping the System i server from your workstation. Also, verify that a firewall or antivirus software is not blocking your installation process.

If you cannot turn off your firewall or your antivirus software, or if you have a slow connection to the System i server, we recommend that you use the local silent installation instead. See 3.4.2, “Silent installation” on page 48.

### 3.9.2 Security issues

Remember that the i5/OS user ID you use for the installation:

- ▶ Must have \*ALLOBJ and \*SECADM special authorities
- ▶ Must be enabled
- ▶ The password must not have expired

If your installation user does not have the special authorities assigned, the window in Figure 3-41 is displayed.

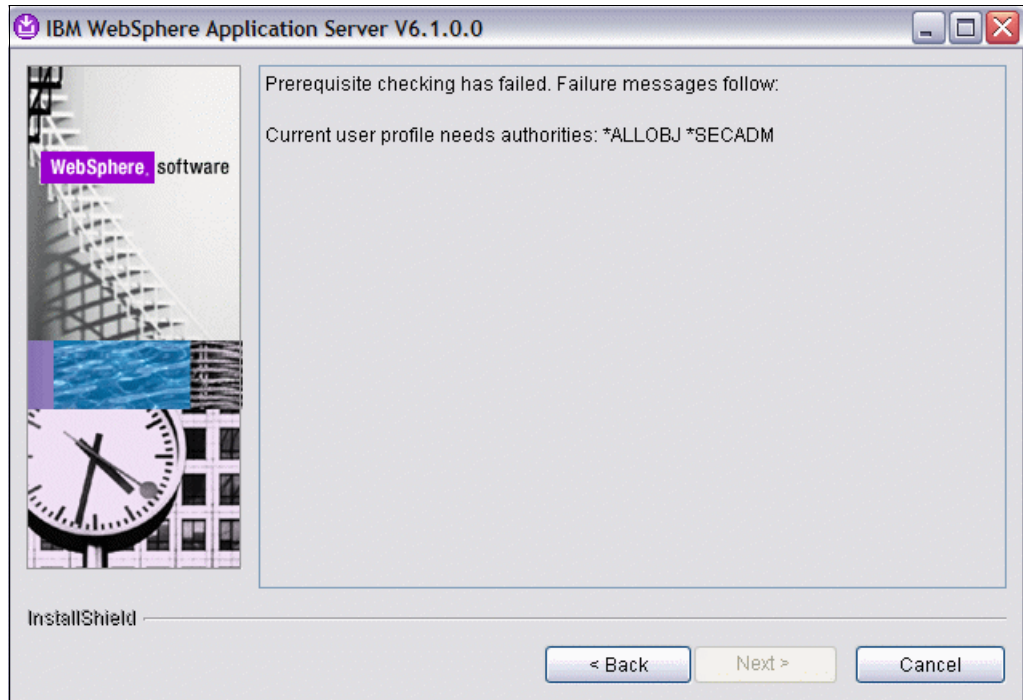

Figure 3-41 Special authorities not granted window

If the password for the user ID expired, the message in Figure 3-42 is displayed.

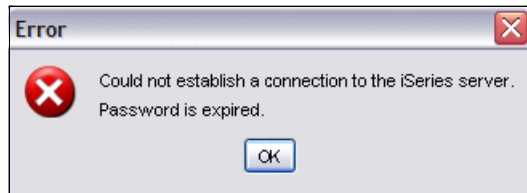

Figure 3-42 Password expired panel

If you specify an incorrect password, the installer shows a window that is similar to Figure 3-43.

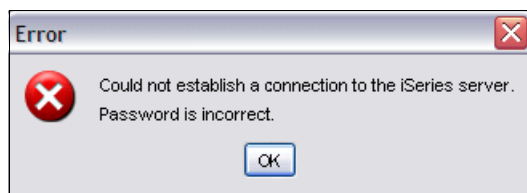

Figure 3-43 Password incorrect panel

### 3.9.3 Prerequisite check failed

During the installation process, the installer executes the system prerequisites check. In this part of the installation, PTF levels and required licensed programs are checked. If any prerequisites are not installed, an error message is displayed as shown in Figure 3-44, which shows missing PTFs.

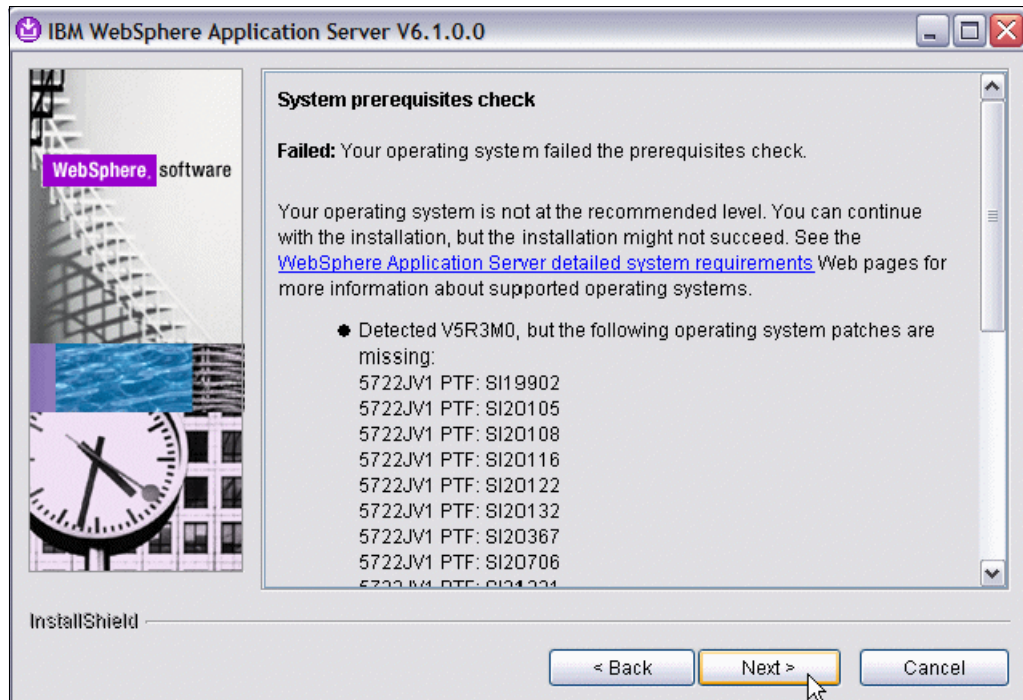

Figure 3-44 Prerequisites failed

Remember that you need IBM Developer Kit for Java Version 5 (5722-JV1 option 7) to install and run WebSphere Application Server.

In some cases (such as a missing PTF), the installer allows you to continue, but this results in a failed installation.

### 3.9.4 Silent install problems

Some of the most common problems when installing WebSphere Application Server V6.1 using the silent install mode are due to the following:

- ▶ You did not accept the license
- ▶ The system does not have prerequisite PTFs installed
- ▶ You did not specify user name and password when you chose to enable Administrative Security
- ▶ You did not specify the samplesPassword when you chose to install Sample Applications with Administrative Security enabled

The installation script shows you a message that describes any errors. See Figure 3-45 on page 80 for an example of a failed silent install.

```
QSH Command Entry

(Aug 22, 2006 10:57:44 AM), Process, com.installshield.wizardx.conditions.PlatformWizardBeanCondition, dbg.platform, condition platform: name="AIX" version="." arch="." (Aug 22, 2006 10:57:44 AM), Process,
com.ibm.ws.install.ni.ismp.actions.ISMPW
arningDialogAction, wrn, INSTCONFFAILED : LICENSE_NOT_ACCEPTED : Accept the
license agreement in the response file before installing. Correct the
specification to proceed. (Aug 22, 2006 10:57:44 AM), Process,
com.ibm.ws.install.ni.ismp.actions.SetExitCodeAction, msg1, CWUPI0000I:
EXITCODE=1 (Aug 22, 2006 10:57:44 AM), Process,
com.ibm.ws.install.ni.ismp.actions.ISMPLogSuccessMessageAction, msg1,
INSTCONFFAILED
    Wizard.getExitCode(): called after WizardServices is shutdown.
    Wizard.getExitCode(): called after WizardServices is shutdown.
    $

====>
F3=Exit F6=Print F9=Retrieve F12=Disconnect
F13=Clear F17=Top F18=Bottom F21=CL command entry
```

Figure 3-45 Silent Install error due to not accepting the product license

### 3.9.5 Miscellaneous problems

The following list contains some common problems for all types of installations:

- ▶ Qshell not properly installed. Missing /usr/bin links to utilities or not in PATH
- ▶ Unusual settings in the RSTOBJ command. The installation uses this command to restore the native code for the product, for example:  
OBJTYPE not equal \*ALL

### 3.9.6 Where to find the logs

After installation completes, you can find logs in the following directory:

```
<was_install_root>/logs/install
```

The installer shows you the path of the logs after an installation failed (see Figure 3-46 on page 81). In our example, we use the standard path installation for WebSphere Application Server V6.1 Base.

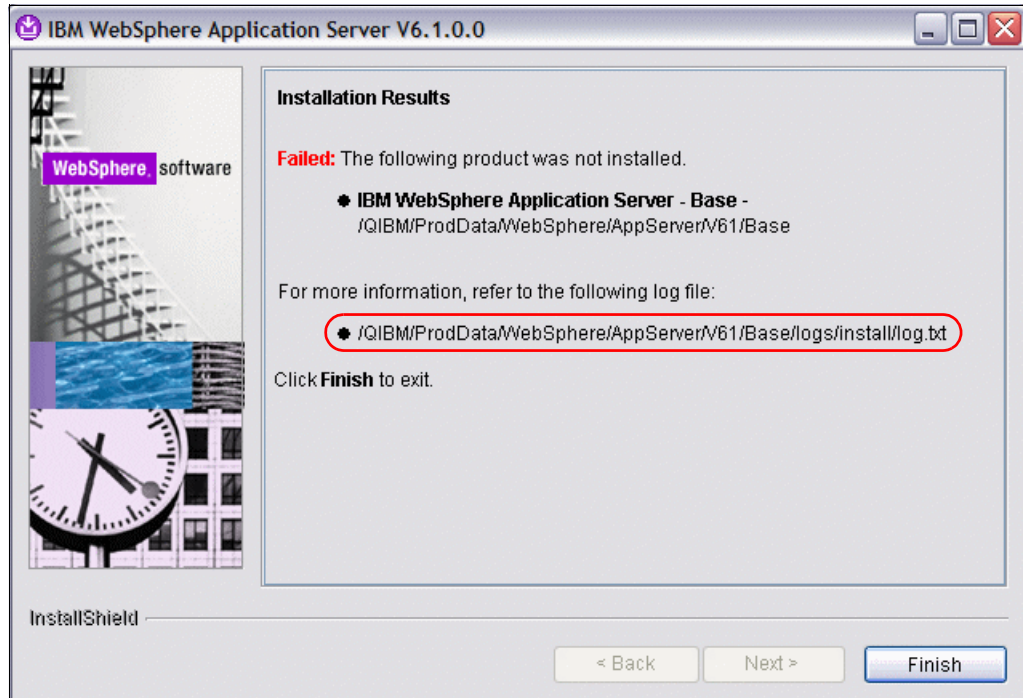

Figure 3-46 Installation failed

## What is in the logs

There are several install-related log files that are in the <was\_install\_root>/logs/install/ directory:

- |                          |   |
|--------------------------|---|
| <b>log.txt</b>           | The main installer log, which contains information about the type of install, the user who is doing the install, the options specified, and the progress of the install.                            |
| <b>trace.txt</b>         | A more readable form of the log.txt file with less details (see example in Figure 3-47 on page 82). However, you can adjust the level of details for a silent installation using the response file. |
| <b>trace.xml</b>         | The XML version of trace.txt, which you can view with third-party tools like Chainsaw.  |
| <b>installconfig.log</b> | Contains the executions log of the configuration actions for the installation.  |

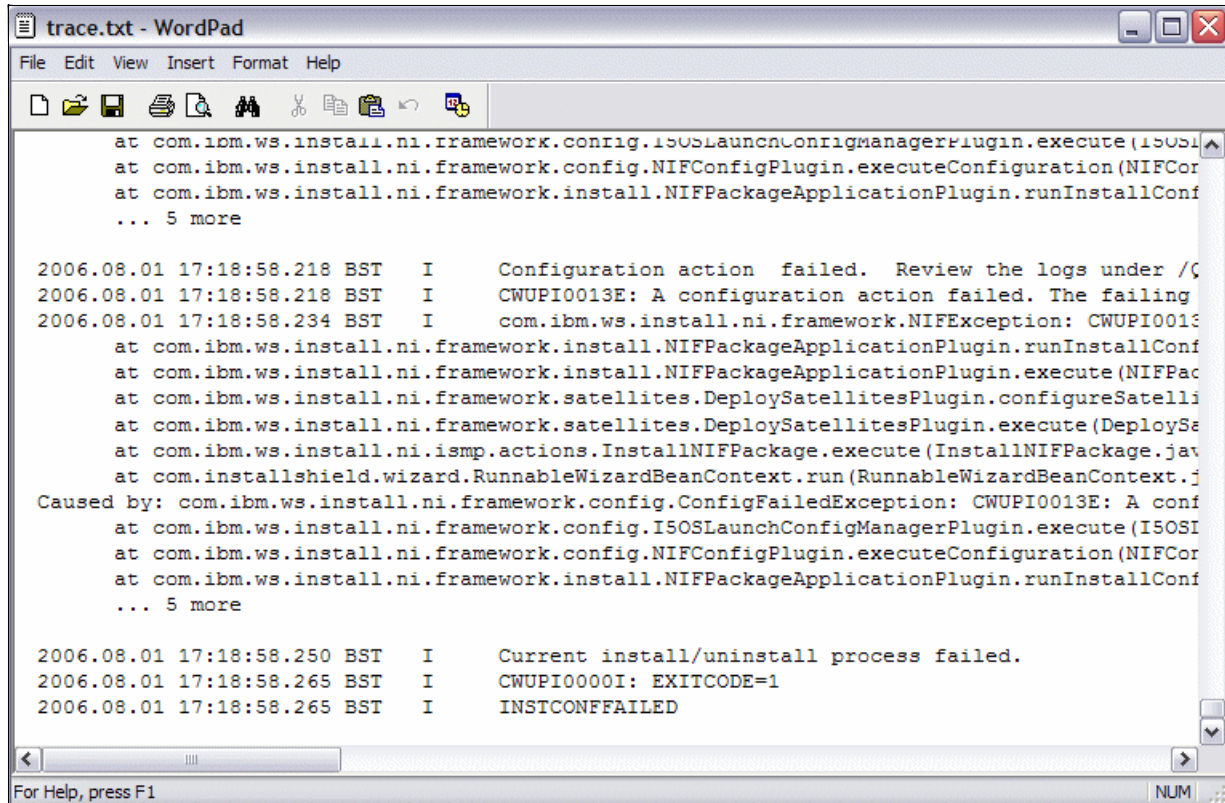

Figure 3-47 Reviewing the trace.txt with Notepad

### 3.9.7 Recovering from a failed install

If your installation fails, and you need to reinstall the product, perform the following procedures:

1. Try to run the uninstall command (see 3.10, “Uninstalling WebSphere Application Server” on page 82). In almost all situations you should have the uninstaller: the installation process lays down the uninstaller files first.
2. If the file /tmp/Installshield/cielInstall.lock exists, delete this file; otherwise, subsequent installs will fail and indicate that an install is already in progress. Remember that only one installation will run at a given time.
3. Delete the directories that are specified for installLocation and defaultProfileLocation
  - rm -R <installLocation>
  - rm -R <defaultProfileLocation>
4. Do not delete entries from the vpd.registry file.

## 3.10 Uninstalling WebSphere Application Server

In this section, we describe how to properly uninstall WebSphere Application Server V6.1 from your i5/OS system. You must use the `uninstall` script to remove the product from your system:

1. Start a 5250 emulator session and sign on.
2. Start QShell with the STRQSH command.

3. Go to the bin directory for your installation:

```
cd <install_directory>/bin/
```

Example:

```
cd /QIBM/ProdData/WebSphere/AppServer/V61/Base/bin/
```

4. Execute the **uninstall** script. Figure 3-48 shows the result of a successfully uninstall.

```
QSH Command Entry

 11NIFPackage, msg1, Uninstalling component: legal, percent complete: 99%
   (Aug 15, 2006 10:48:16 AM), Process,
com.ibm.ws.install.ni.ismp.actions.InstallNIFPackage, msg1, Uninstalling
component: nif.componentmap.primary, percent complete: 100% (Aug 15, 2006
10:48:17 AM), Process,
com.ibm.ws.install.ni.ismp.actions.SettleNIFRegistryAction, msg1, Current
install/uninstall process is successful. Process type is: uninstall
   (Aug 15, 2006 10:48:17 AM), Process,
com.ibm.ws.install.ni.ismp.actions.SetExitCodeAction, msg1, CWUPI0000I:
EXITCODE=0
   (Aug 15, 2006 10:48:17 AM), Process,com.ibm.ws.install.ni.ismp.actions.ISMPL
ogSuccessMessageAction, msg1, INSTCONFSUCCESS
Wizard.getExitCode(): called after WizardServices is shutdown.
Wizard.getExitCode(): called after WizardServices is shutdown.
$

====>

F3=Exit   F6=Print F9=Retrieve F12=Disconnect
F13=Clear F17=Top  F18=Bottom F21=CL command entry
```

Figure 3-48 Uninstall of WebSphere Application Server is complete

5. Unlike multiplatform installations, profiles are not deleted by default. If you want to delete all profiles, you must specify the **removeProfilesOnUninstall** parameter when you uninstall, for example:

```
uninstall -OPT removeProfilesOnUninstall="true"
```

**Restriction:** The i5/OS command DLTLICPGM is no longer supported for WebSphere Application Server V6.1.

6. Uninstall does not completely delete the product install directory; instead, it leaves the log files in place. If you want to reuse the same location for a new installation, you must delete the product directory using the **rm -R <install\_directory>** command, for example:

```
rm -R /QIBM/ProdData/WebSphere/AppServer/V61/Base/
```

7. If you do not use the profile removal option, you can use the **rm -R <defaultProfileLocation>** command to remove the user data directory after uninstall, for example:

```
rm -R /QIBM/UserData/WebSphere/AppServer/V61/Base/profiles/
```





## Day-to-day operations

In this chapter, we describe typical day-to-day operations that a WebSphere Application Server administrator may expect to perform. We expand this topic in the following three chapters where we cover Web server management, application management, and scripting.

The following list contains the day-to-day operations that we cover in this chapter:

- ▶ 4.2.1, “Starting IBM Web Administration for i5/OS” on page 89
- ▶ 4.2.6, “Accessing the WebSphere Administrative Console” on page 121
- ▶ 4.2.2, “Creating an application server profile” on page 92
- ▶ 4.2.7, “Listing the existing WebSphere profiles” on page 126
- ▶ 4.2.8, “Deleting an application server profile” on page 127
- ▶ 4.2.5, “Running QShell scripts from the profile’s home directory” on page 120
- ▶ 4.2.9, “Creating an application server cell” on page 134
- ▶ 4.2.3, “Starting an application server” on page 107
- ▶ 4.2.4, “Stopping an application server” on page 113
- ▶ 4.2.10, “Working with application server log files” on page 143
- ▶ 4.2.11, “Discovering TCP/IP ports assigned to the profile” on page 151
- ▶ 4.2.13, “Auto-starting WebSphere Application Server” on page 159

## 4.1 Overview of the WebSphere profiles

A WebSphere profile is a set of files that define the runtime environment. A profile includes configuration, application, log, and other files that in concert define how an application server is configured and what applications are available on that server.

Starting from WebSphere Application Server V6.0, the profiles are created based on one of the predefined templates. A template includes a specific set of configuration options that are used during profile creation. Based on your goals, you select one of the templates during profile creation.

Template definitions are located in the <WebSphere\_install\_root>/profileTemplates directory, where <WebSphere\_install\_root> relates to the application server root catalog, specified during the installation process. Each template is represented with a separate folder that, in its turn, contains several subfolders. The number of templates depends on the WebSphere Application Server edition.

You can create a WebSphere profile in i5/OS in several ways: some of them work across all supported platforms, and some, like using IBM Web Administration for i5/OS, are unique to i5/OS. The manageprofiles script is supported on all platforms and is used to create and manage a WebSphere profile. One of the script parameters, called **-templatePath**, is a path to the location of the profile template directory. By changing this parameter, you control the type of a WebSphere profile that is created. In the following sections, we provide more information about all supported templates.

### 4.1.1 Types of profiles

In this section, we provide a description for each profile template that is shipped with WebSphere Application Server. The product includes a variety of pre-configured templates, although it is possible to create your own.

**Attention:** Some of the profile templates that we list in this section can only be created in WebSphere Application Server Network Deployment Edition and are marked as such.

#### Default profile

A *default* profile template is shipped with the product. A profile is a set of configuration files and installed applications that make up your WebSphere Application Server environment.

The default WebSphere Application Server profile template provides the necessary configuration files for creating and managing a stand-alone application server. This profile provides the services and resources that are required to deploy and run enterprise applications on a single application server.

The name of the default WebSphere profile template is `default`. Specify `default` for the **-templatePath** parameter to create this type of profile.

**Tip:** If you are new to WebSphere Application Server, we recommend that you start with the default profile.

#### HTTP server profile template

The HTTP server profile template does not contain an application server, but rather contains configuration and log files to configure a remote HTTP server topology. You can use an HTTP server profile to facilitate the creation of Web server definitions in WebSphere Application

Server. See 5.3, “Configuring a remote Web server with WebSphere Application Server” on page 171 for creating a remote HTTP server environment.

Specify **http** for the **-templatePath** parameter to create this type of profile.

### **Deployment manager profile template (WebSphere Application Server Network Deployment only)**

The basic functions of the deployment manager are to manage a collection of the distributed application servers for high availability, fail-over support, and distributed application deployment. This profile contains the Network Deployment administrative console application and the Network Deployment file transfer application. These applications enable the distributed management of one or more WebSphere Application Server profiles, or nodes.

Specify **dmgr** for the **-templatePath** parameter to create this type of profile.

### **Custom profile template (WebSphere Application Server Network Deployment only)**

The basic function of this profile template, which belongs to a deployment manager cell, is to act as a deployment manager proxy on every physical system that is part of the cell. A custom profile does not have its own administrative console; instead, it is there to support distributed deployment of multiple application servers. As a result, a custom profile does not run any user application. It just enables the deployment manager to control a set of the servers (part of the deployment manager cell) that run on that physical system. You may create more than one custom profile on a system. Unless you have some special requirements, we recommend that you use one custom profile per machine or partition.

Specify **managed** for the **-templatePath** parameter to create this type of profile.

### **Cell profile template (WebSphere Application Server Network Deployment only)**

The basic function of the cell profile is to create a complete deployment manager cell. As such, the cell profile requires to perform multiple steps to create the entire cell configuration: deployment manager, managed node (customer profile template), and application servers. Later, you can create more application servers and managed nodes and add them to the cell.

## **4.1.2 Profile directory structure**

The directory structure for the product has two major sets of files in the installation root directory, as shown in Figure 4-1 on page 88.

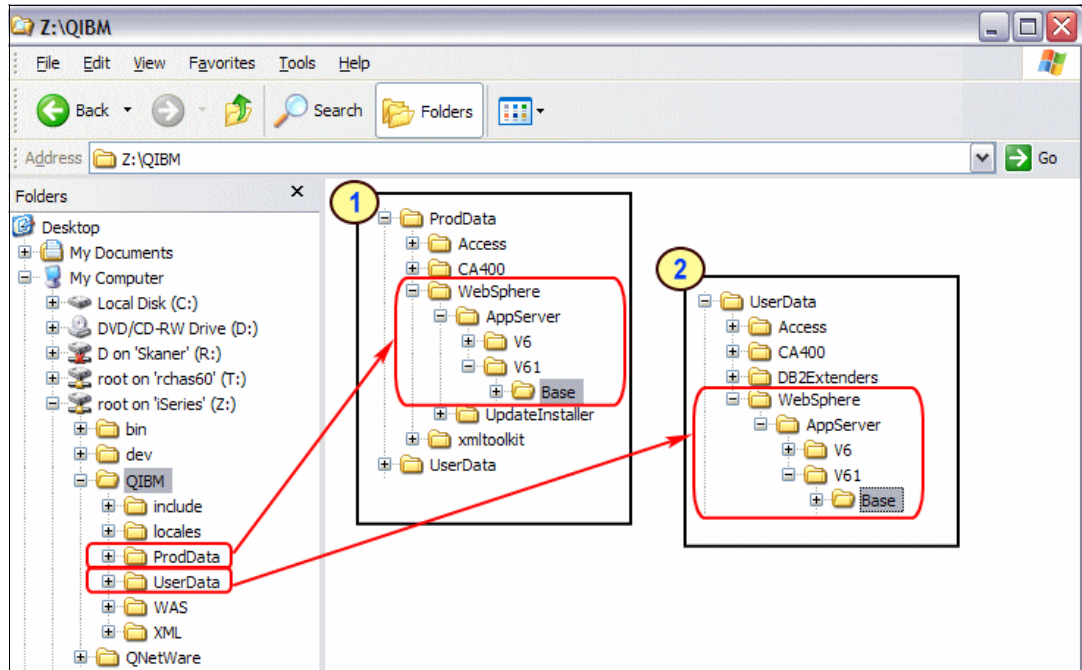

Figure 4-1 WebSphere Application Server directory structure-files associated with a profile are under UserData

The core product files are shared product binary files that do not change unless you install a refresh pack, a fix pack, or an interim fix. They are located in the ProdData subdirectory. We use <WebSphere\_install\_root> to represent this directory. The default installation location for the WebSphere Application Server Base product files is:

```
/QIBM/ProdData/WebSphere/AppServer/V61/Base/
```

The <user\_data\_root> represents the location of all profiles configuration files. These files are located under the UserData subtree. The default location for the WebSphere Application Server Base user files is:

```
/QIBM/UserData/WebSphere/AppServer/V61/Base/profiles/
```

## 4.2 Day-to-day administration

Performing day-to-day WebSphere Application Server administration tasks is the main topic of this chapter. We use start-to-finish examples that show you exactly how to perform the most common administration tasks.

Some of the tasks are presented from two different perspectives: by using the IBM Web Administration for i5/OS tool and also through using Qshell scripts. The method you choose depends on your level of familiarity with WebSphere Application Server and your confidence with using command-line tools versus interacting with a GUI. Its also worth pointing out that most scripts that are used in Qshell are available across all WebSphere Application Server platforms, whereas IBM Web Administration for i5/OS is unique to the System i platform.

## 4.2.1 Starting IBM Web Administration for i5/OS

IBM Web Administration for i5/OS combines forms, tools, and wizards to create a simplified environment to set up and manage many different servers and server types on your System i5™ server. IBM Web Administration for i5/OS is a Web-based tool that allows you to work with HTTP server instances, IBM WebSphere Application Server profiles, WebSphere Portal instances, and so on.

In this section, we describe how to start IBM Web Administration for i5/OS, which by default does not necessarily have to be started.

You can start IBM Web Administration for i5/OS by using one of the following two methods. One method uses the i5/OS command line, where you can type the following command:

```
STRTCPSVR SERVER(*HTTP) HTTPSVR(*ADMIN)
```

The other method is to use iSeries Navigator as explained in the following steps:

1. Start iSeries Navigator.
2. In the iSeries Navigator left panel, expand **My Connections** → *<your i5 host>* → **Network** → **Servers**, and click **TCP/IP**.
3. From the list of servers that is displayed in the right panel, right-click **HTTP Administration**, and select **Start**, as we show in Figure 4-2.

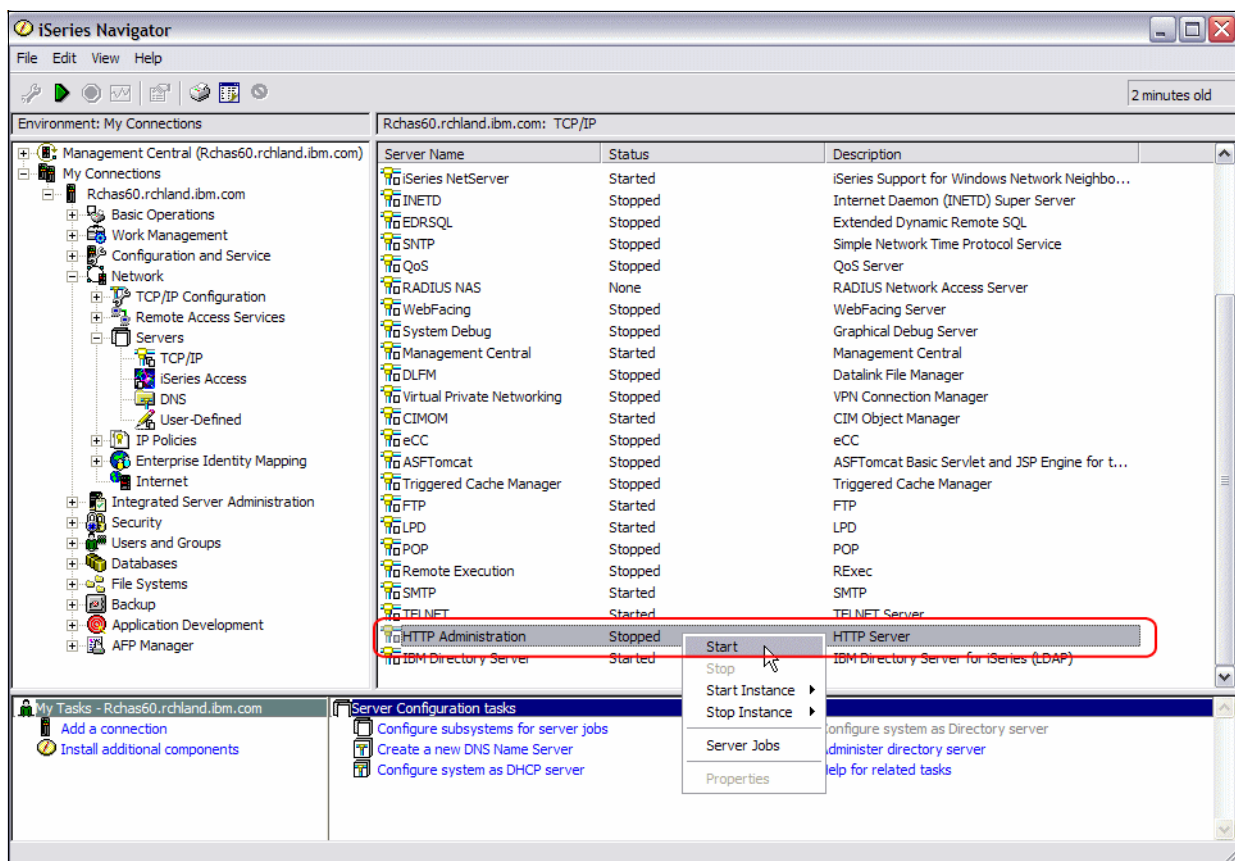

Figure 4-2 iSeries Navigator - HTTP Administration TCP/IP job

After HTTP Administration is started, the QHTTSPVR subsystem is active. Figure 4-3 shows the jobs that are running in this subsystem.

Job Name	Detailed Status	Current User	Type	CPU %	Run Priority	Thread Count
Qhtpsvr	Waiting for dequeue	Qsys	Subsystem	0.0	0	2
Admin	Waiting for signal	Qtmhhttp	Batch - Server	0.0	25	1
Admin	Waiting for signal	Qtmhhttp	Batch immediate - Server	0.0	25	1
Admin	Waiting for Java program	Qtmhhttp	Batch - Server	5.5	25	34
Admin	Waiting for signal	Qtmhhttp	Batch immediate - Server	0.0	25	24
Admin	Waiting for time interval	Rafja	Batch immediate - Server	0.0	25	1

Figure 4-3 QHTTSPVR jobs

The next step is to open the IBM Web Administration for i5/OS GUI:

1. Navigate to the following Web address:

`http://hostname:2001/`

In the Web address, *hostname* is the host name or IP address of the i5/OS server where the HTTP server was started. Port 2001 is the default port for accessing IBM Web Administration for i5/OS. To view what port is assigned to this interface on your system, use the WRKSRVTBLE command and find the `as-admin-http` entry in the table.

2. The login window opens as shown in Figure 4-4. Type a valid i5/OS user profile name and password, and click **OK**.

**Important:** To be authorized to log into IBM Web Administration for i5/OS application, the i5/OS user profile must have \*IOSYSCFG special authority.

Connect to rchas60

HTTP Admin

User name:

Password:

Remember my password

OK Cancel

Figure 4-4 IBM Web Administration for i5/OS login panel

3. After a successful login, the i5/OS Tasks page is displayed, as shown in Figure 4-5. To work with HTTP Server (powered by Apache) and the IBM WebSphere Application Server profiles, click **IBM Web Administration for i5/OS**.



Figure 4-5 i5/OS Tasks page

**Important:** We recommend that you install the latest HTTP Server for i5/OS PTFs on your system, prior to using IBM Web Administration for i5/OS. See the following Web site for more information:

<http://www-03.ibm.com/servers/eserver/series/software/http/services/service.html#PTF>

The IBM Web Administration for i5/OS start page displays, as shown in Figure 4-6 on page 92.

**Note:** After you use IBM Web Administration for i5/OS for the first time, the state is retained so you are not necessarily returned to the same window when you next use IBM Web Administration for i5/OS.

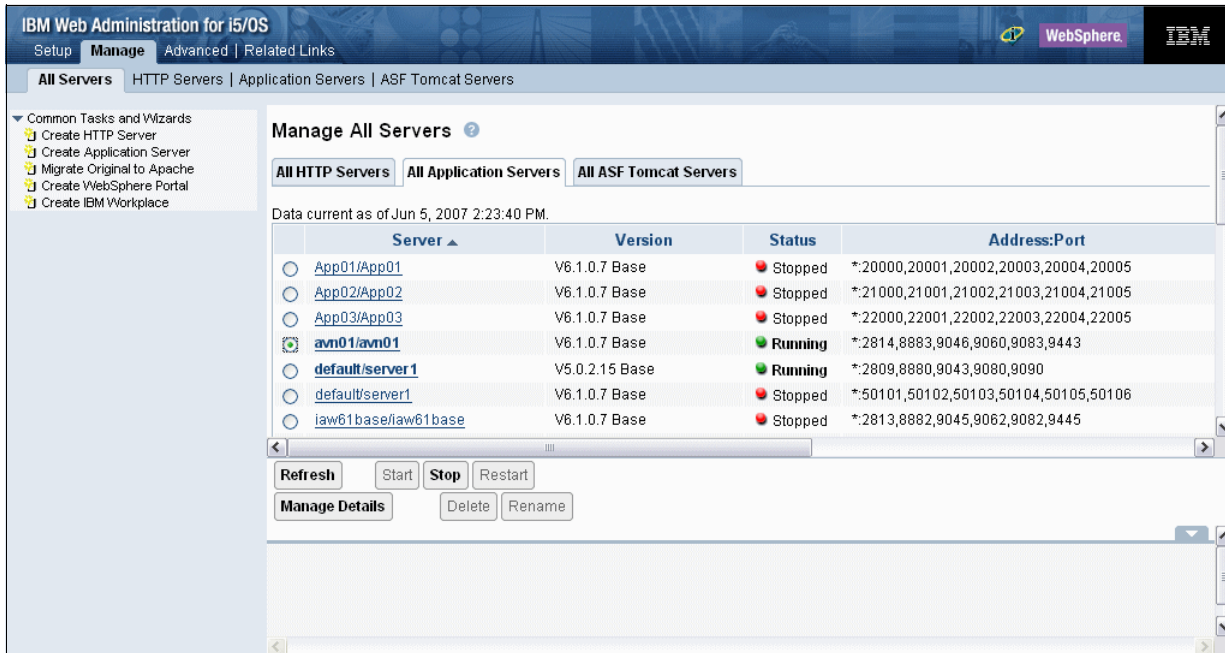

Figure 4-6 IBM Web Administration for i5/OS start page

## 4.2.2 Creating an application server profile

The following example describes the process of creating an application server profile using both Qshell (through the manageprofiles script) and IBM Web Administration for i5/OS.

### Creating an application server profile using the manageprofiles script

In this example, we describe a way to create an application server profile from a Qshell environment using the manageprofiles script.

Table 4-1, “The manageprofiles parameters” on page 92 lists the parameters, along with a brief description, and the values that we used when we invoke the manageprofiles script.

Table 4-1 The manageprofiles parameters

Parameter name	Sample value	Description
-profileName	WASSvr01	Specifies the name of the profile. Use a unique value when you create a profile. Each profile that shares the same set of product binaries must have a unique name. The value for this parameter must not contain spaces or characters that are not valid, such as *, ?, <, >, ,, /, \,  , and so on. The profile name that you choose must not be in use.

Parameter name	Sample value	Description
-templatePath	default	Specifies the directory path to the template files. Within the profileTemplates directory, there are various directories that correspond to different profile types and that vary with the type of product that is installed. The profile directories are the paths that you indicate while using the -templatePath option. You can specify profile templates that lie outside of the installation root, if you happen to have any.  For the predefined templates in i5/OS, you need to specify the directory name only. You do not need to specify the entire path. See 4.1.1, "Types of profiles" on page 86 for more information.
-startingPort	53001	Specifies the starting port number for generating all ports for the profile. Port values are assigned sequentially from the -startingPort value.

Complete the following steps to create the application server profile:

1. Start a QShell session with the STRQSH command.
2. Change to the core binary product files location:

```
cd /QIBM/ProdData/WebSphere/AppServer/V61/Base/bin
```

**Note:** The default location of the core binary product files can change depending on the application server edition, type, or custom settings. In our examples, we assume WebSphere Application Server V6.1 Base is installed in the default location.

3. Run the manageprofiles script with the parameters specified in Table 4-1, "The manageprofiles parameters" on page 92.

```
manageprofiles -create -profileName WASSvr01 -templatePath default
-startingPort 53001
```

**Note:** On i5/OS, you do not need to specify the -templatePath parameter if you are creating a standalone application server profile, because -templatePath uses the default profile template if no template is specified.

Example 4-1 shows the manageprofiles output messages.

*Example 4-1 Creating of an application server profile*

---

```
> manageprofiles -create -profileName WASSvr01 -templatePath default -startingPort
53001
INSTCONFSUCCESS: Success: Profile WASSvr01 now exists. Please consult
/QIBM/UserData/WebSphere/AppServer/V61/Base/profiles/WASSvr01/logs/AboutThisProfil
e.txt for more information about this profile.
$
===>
```

---

The command completed successfully and the profile was created based on the parameters sent to the manageprofiles script. As the output of the manageprofiles script indicates, more information about a profile can be found in the AboutThisProfile.txt file located in the <app\_server\_name>/profiles/profile\_name/logs directory.

Example 4-2 is an example of the AboutThisProfile.txt file.

*Example 4-2 AboutThisProfile.txt file content*

---

```
*****Beginning of data*****
Application server environment to create: Application server
Location: /QIBM/UserData/WebSphere/AppServer/V61/Base/profiles/WASSvr01
Disk space required: 200 MB
Profile name: WASSvr01
Make this profile the default: False
Node name: RCHAS60_WASSvr01
Host name: RCHAS60.ITS0.IBM.COM
Enable administrative security (recommended): False
Administrative console port: 53002
Administrative console secure port: 53004
HTTP transport port: 53001
HTTPS transport port: 53003
Bootstrap port: 53005
SOAP connector port: 53006
Run application server as a service: False
Create a Web server definition: False
*****End of Data*****
```

---

After your application server profile is created successfully, it is ready to start and service user requests.

## Creating an application server profile using IBM Web Administration for i5/OS

In this section, we describe how to create an application server profile using IBM Web Administration for i5/OS. We recommend this method for users who want to create their WebSphere Application Server environment quickly and for those who do not feel comfortable using Qshell commands.

IBM Web Administration for i5/OS uses a wizard to obtain the required settings from you. It is a good idea to be prepared for the questions in the wizard; therefore, Table 4-2 contains some of the questions and typical responses you might enter.

*Table 4-2 IBM Web Administration for i5/OS - wizard parameters*

Parameter name	Sample value	Description
Application server type and location	V6.1 Base Default location	Depends on the WebSphere Application Server types and version you have installed. You can choose any of them.
HTTP server type	A new instance	You can: <ul style="list-style-type: none"> <li>▶ Create a new HTTP server instance that is associated with WAS</li> <li>▶ Use any of the existing HTTP servers</li> <li>▶ Not define any HTTP server for this WebSphere profile</li> </ul>
Application server name	WASSvr01	The application server name.
HTTP server name	HTTPSvr01	The HTTP server name.
HTTP server port	53000	HTTP server port - in a production environment this is usually port 80.

Parameter name	Sample value	Description
Application server ports range	53001	The range of the application server ports used.
Application to install	Stay with defaults	Business application to install that is delivered with the WebSphere Application Server product.
SSO identity tokens	Do not configure	There is a way to configure an identity token to support SSL access for the applications that are installed in this application server.

Complete the following steps to create an application server profile using IBM Web Administration for i5/OS:

1. Open and login to IBM Web Administration for i5/OS, as described in 4.2.1, “Starting IBM Web Administration for i5/OS” on page 89.
2. Click the **IBM Web Administration for i5/OS** link. A window similar to Figure 4-7 is displayed.
3. Click the **Create Application Server** link to start the wizard that allows you to create an application server profile, as shown in Figure 4-7.

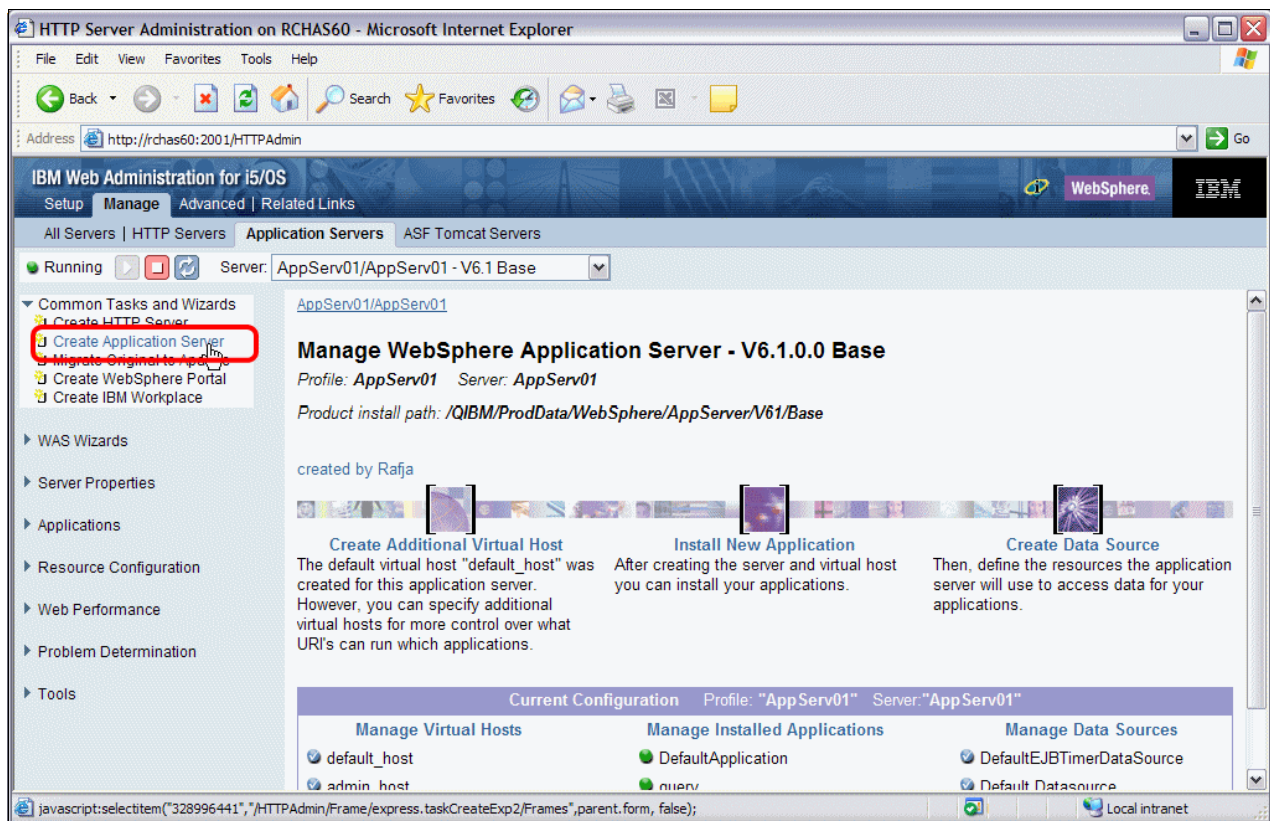

Figure 4-7 IBM Web Administration for i5/OS - Common Tasks and Wizards

4. Review the welcome panel (Figure 4-8), and click **Next**.

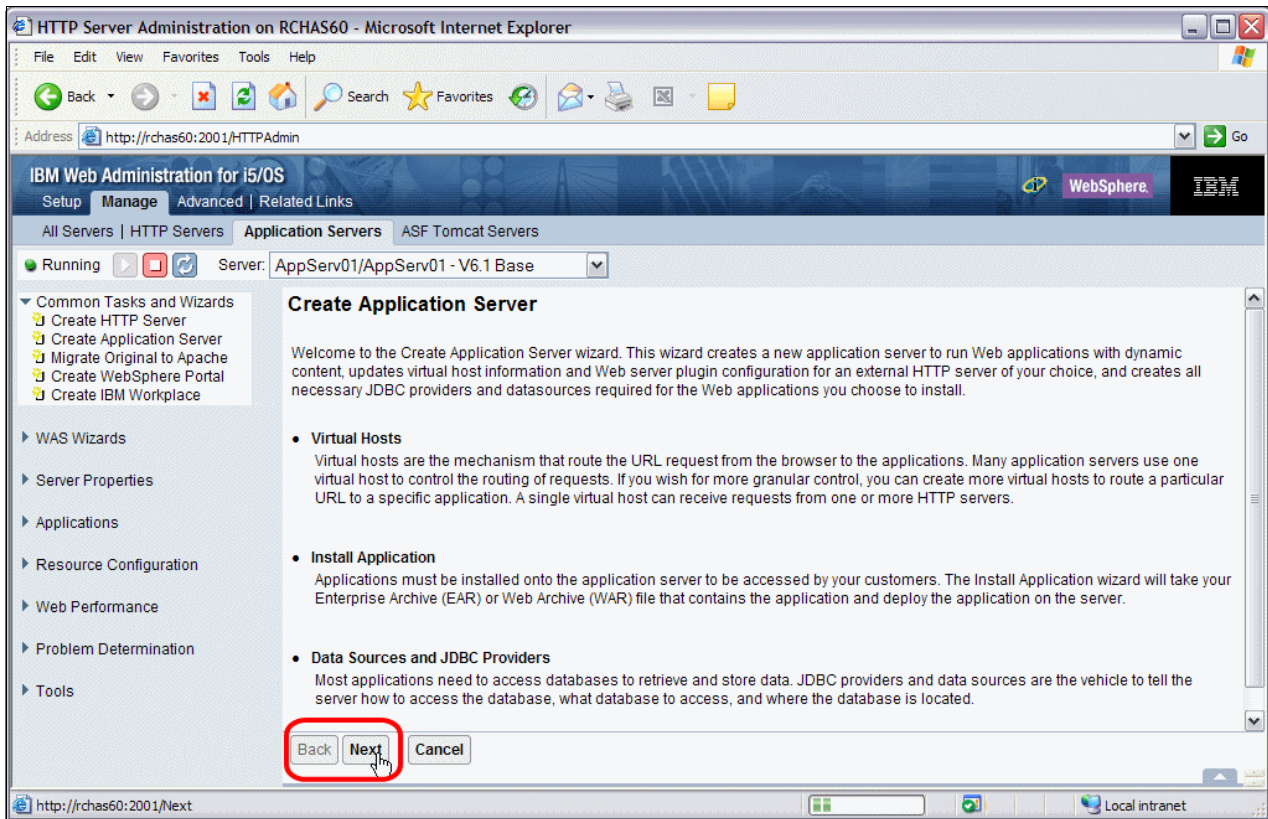

Figure 4-8 IBM Web Administration for i5/OS - Create the Application Server wizard

i5/OS allows for coexistence between different versions and editions of WebSphere Application Server. The wizard detects all of the versions and editions you have installed on your machine and shows them in the next page.

5. Choose the appropriate WebSphere Application Server version, edition, and location, and click **Next** (Figure 4-9).

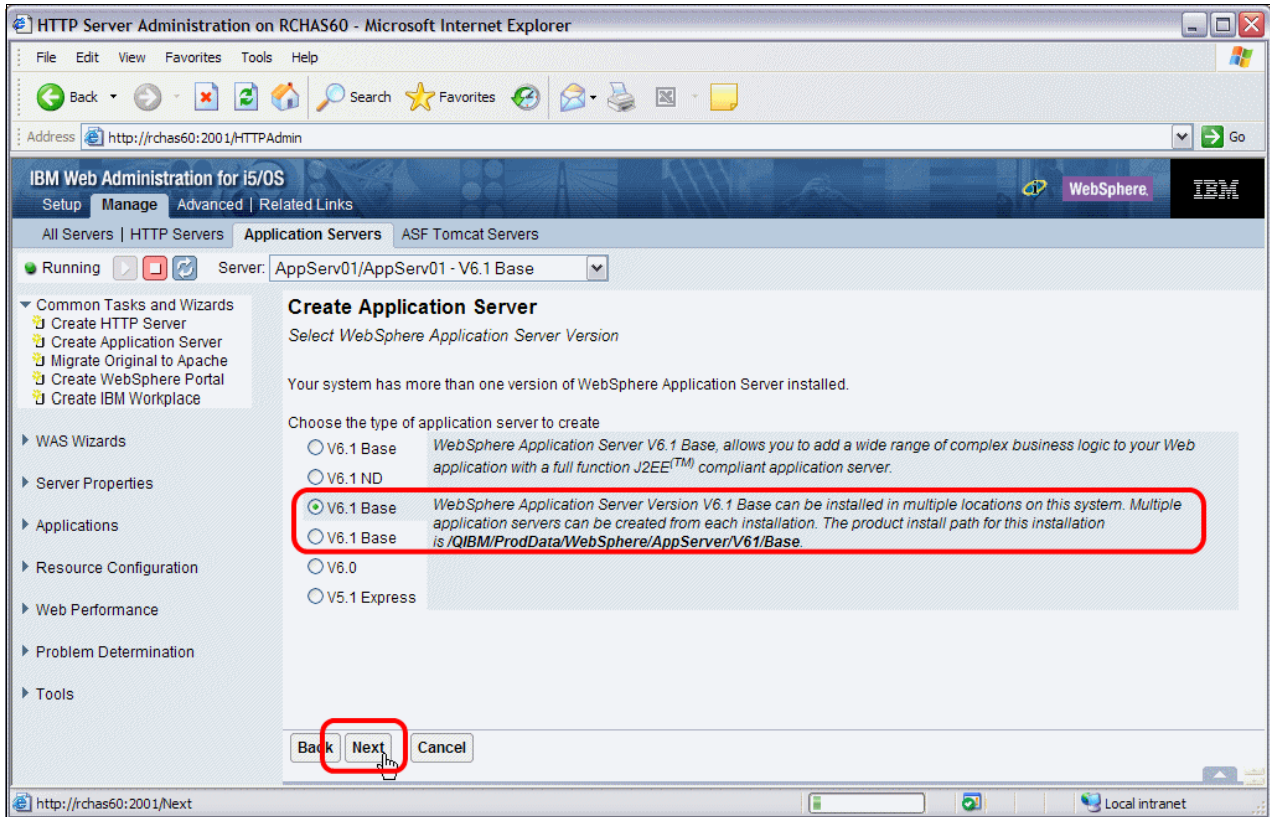

Figure 4-9 IBM Web Administration for i5/OS - Choosing a type of application server

6. Type the name of the application server profile in the Application server name field. You can also type a description in the Server description field. Click **Next**, as shown in Figure 4-10.

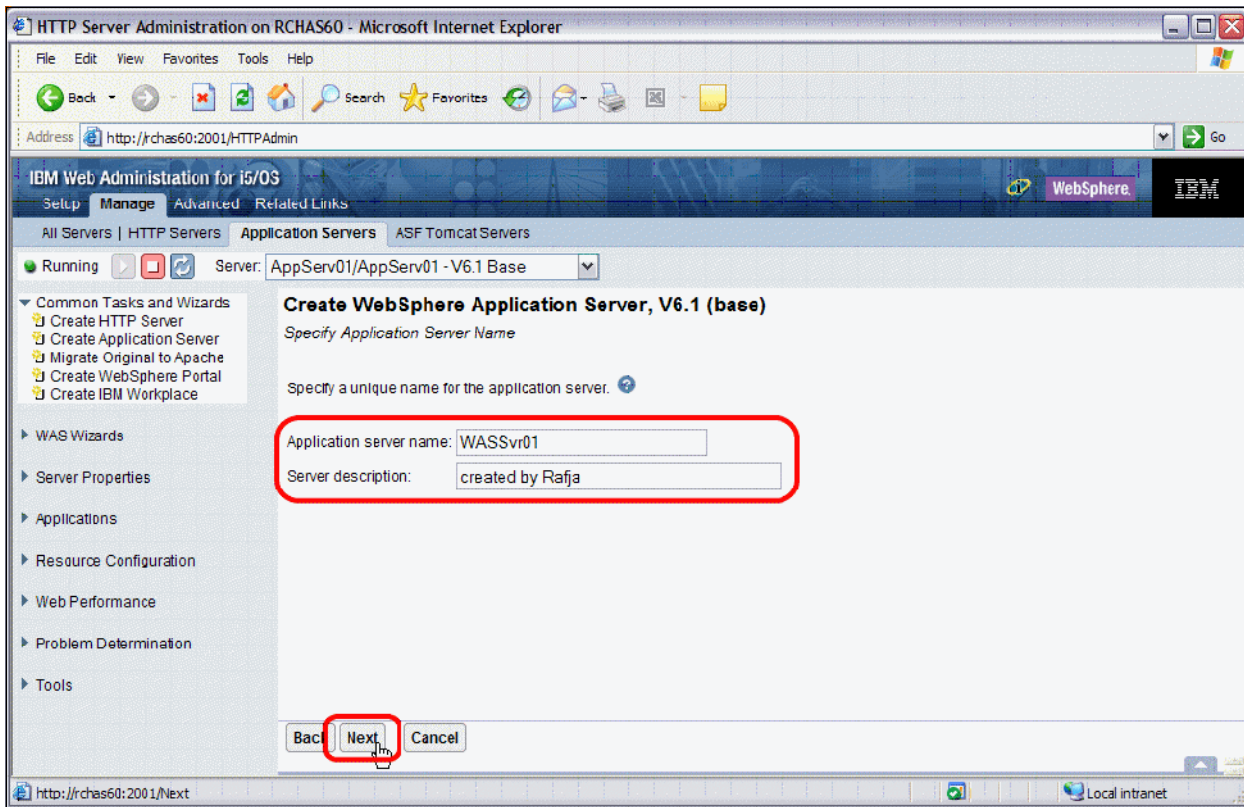

Figure 4-10 IBM Web Administration for i5/OS - Specifying the application server name

7. Figure 4-11 on page 99 allows you to make a decision about the HTTP Server you want to associate with the new application server profile. Your choices are to:
  - Create a new HTTP server instance
  - Select an existing HTTP server instance
  - Do not associate an external HTTP server with this application server

Leave the default selection that instructs the wizard to create a dedicated HTTP server instance, and click **Next** as shown on Figure 4-11 on page 99.

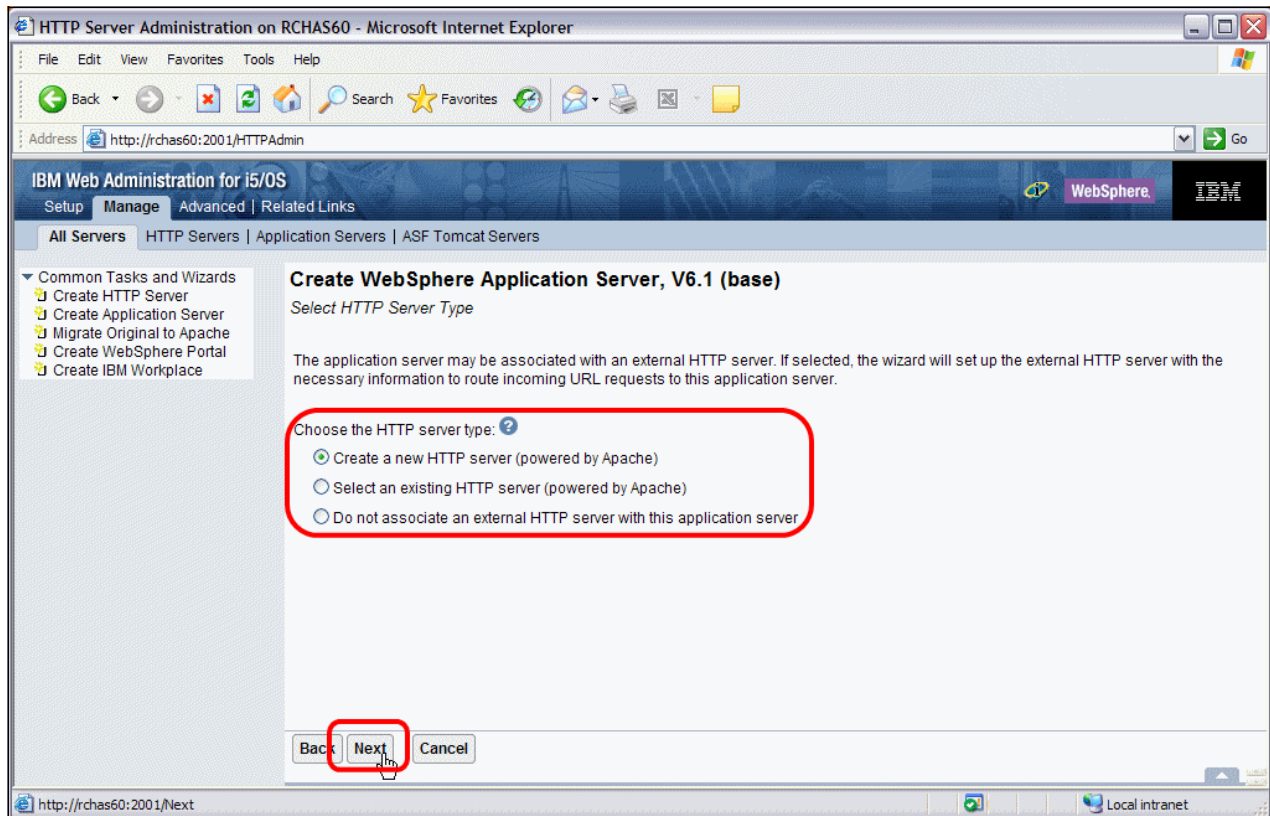

Figure 4-11 IBM Web Administration for i5/OS - Choosing the HTTP server type

8. Next, specify the HTTP server instance parameters (see Figure 4-12 on page 100). Type your HTTP server name in the HTTP Server name field. You can also specify a description. In the bottom part of the window, you are asked to choose the IP address on which your HTTP server instance will listen on. Consider this parameter, especially if your i5/OS partition has multiple Ethernet lines or TCP/IP interfaces.

Choose an IP address or keep the default setting that allows the HTTP server instance to listen on all of the IP addresses that are defined. The next parameter that you have to provide is the port for the HTTP server instance, which is typically set to port 80 in production environments.

Click **Next**, as shown on Figure 4-12 on page 100.

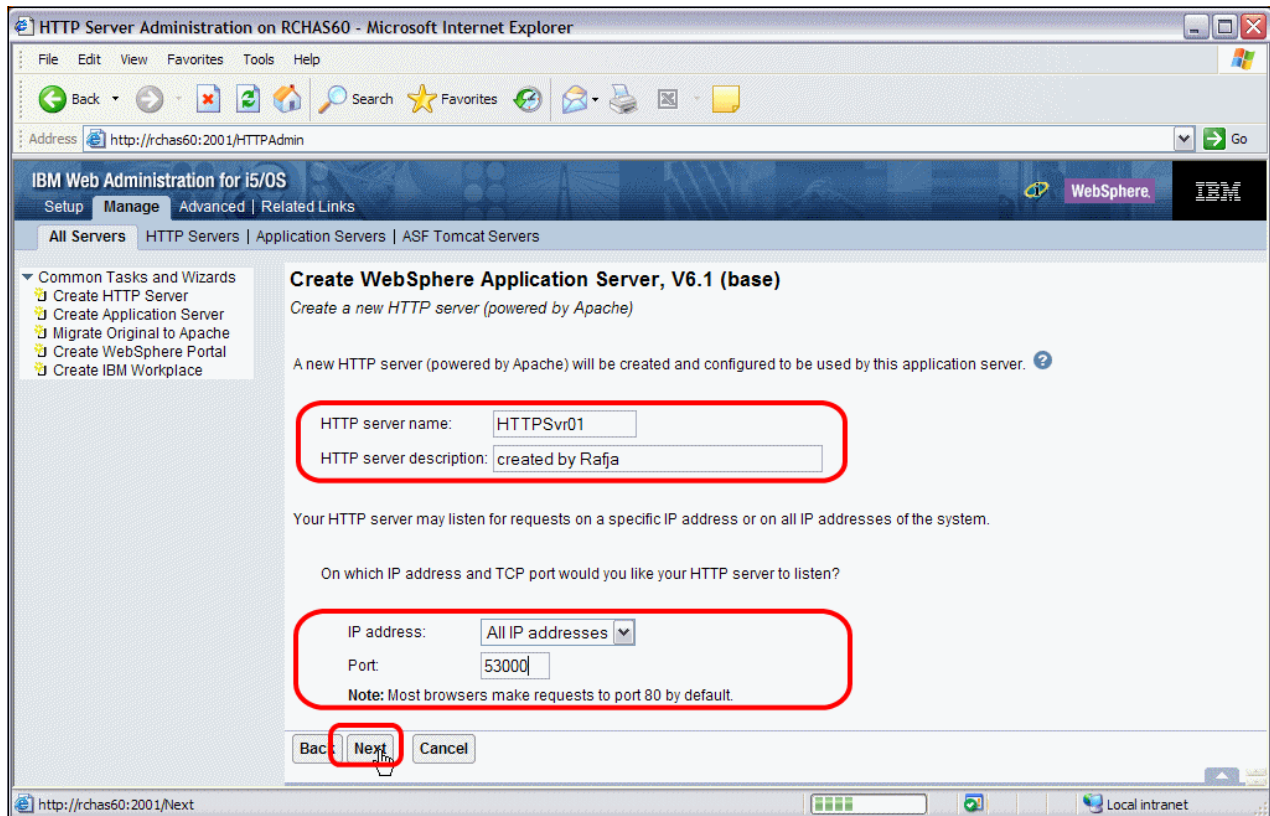

Figure 4-12 IBM Web Administration for i5/OS - Choosing the HTTP server name and port

9. On Figure 4-13 on page 101, specify the first port in the range that the application server profile uses. By default, each application server profile requires 17 consecutive ports. Specify the port value, and click **Next**.

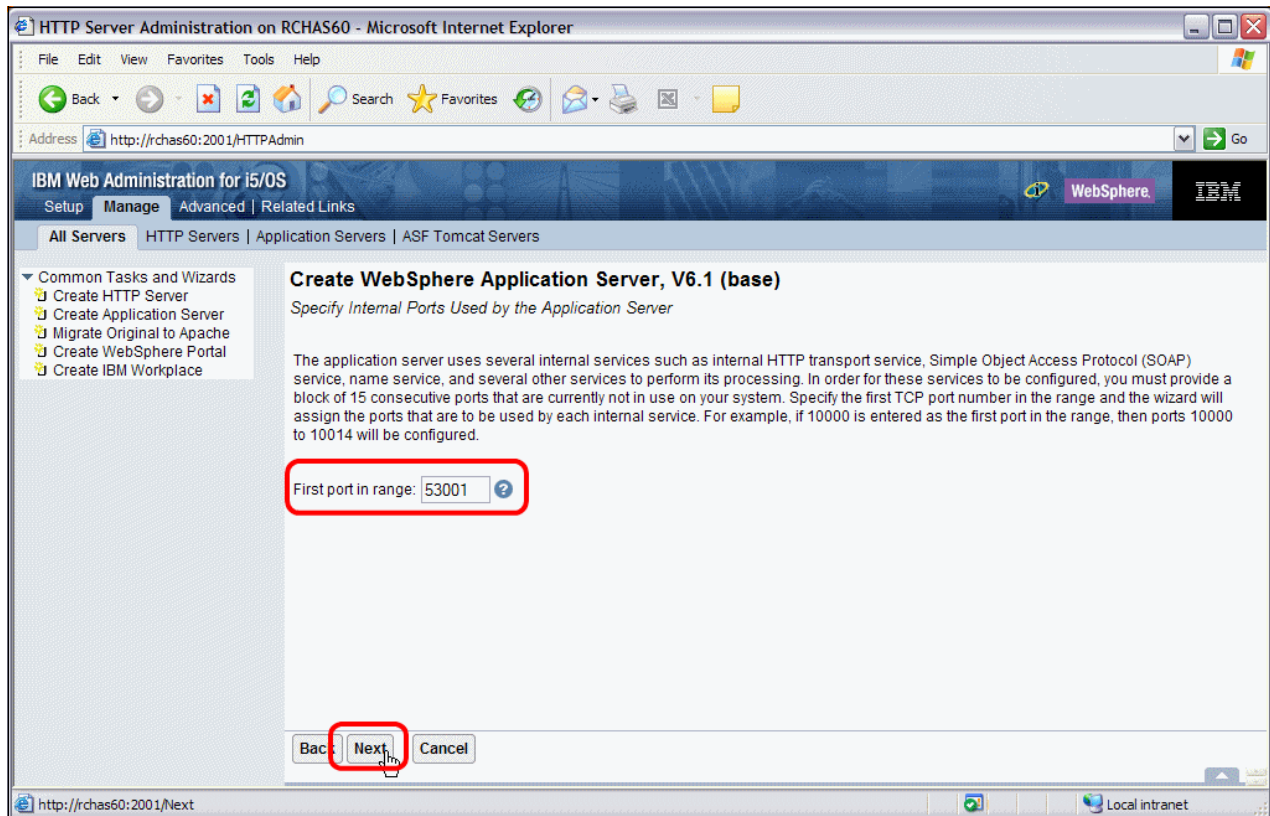

Figure 4-13 IBM Web Administration for i5/OS - Choosing application server's ports range

10. In Figure 4-14 on page 102, choose any of the additional applications that are shipped with the product that you want installed on your application server profile. By default, the Query and Default Applications are installed. Stay with the default settings, and click **Next**.

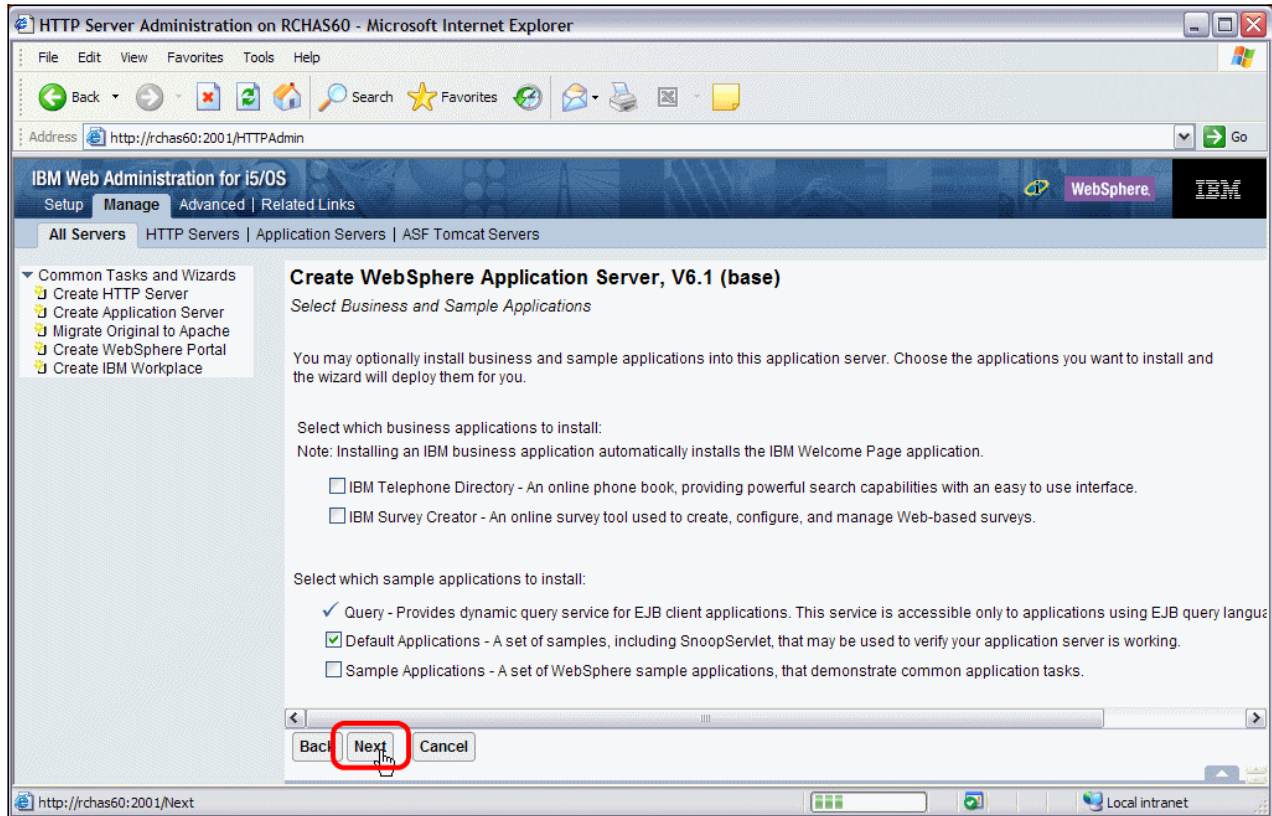

Figure 4-14 IBM Web Administration for i5/OS - Choosing applications to install

11. When the wizard asks you to configure SSO Identity Tokens (Figure 4-15 on page 103), which allow you to set up a Single Sign-On environment, do not configure SSO Identity Tokens at this time. Click **Next**.

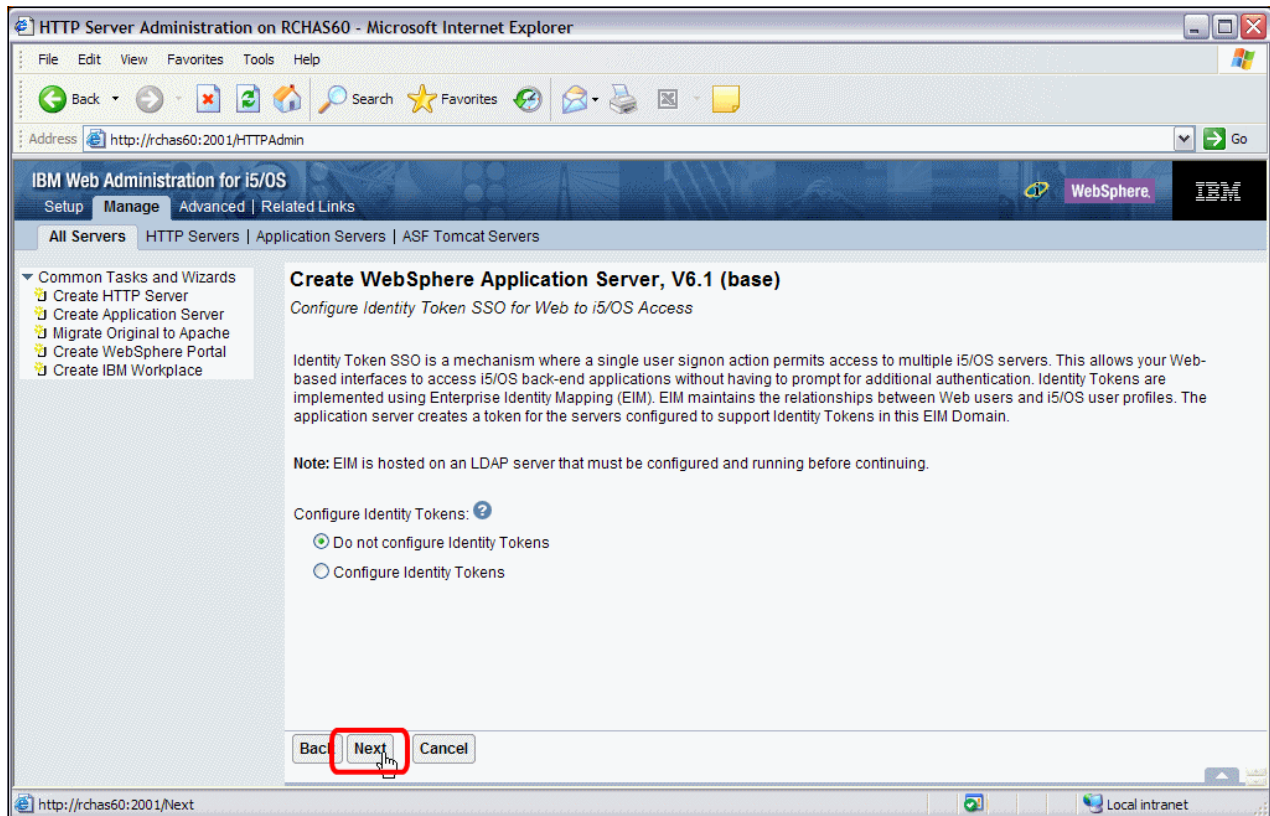

Figure 4-15 IBM Web Administration for i5/OS- Setting up SSO identity tokens

In Figure 4-16 on page 104, the wizard asks you to review all the parameters of the application server profile and HTTP server instance. The Application Server tab summarizes the WebSphere Application Server profile parameters.

12. Click the **HTTP Server** tab.

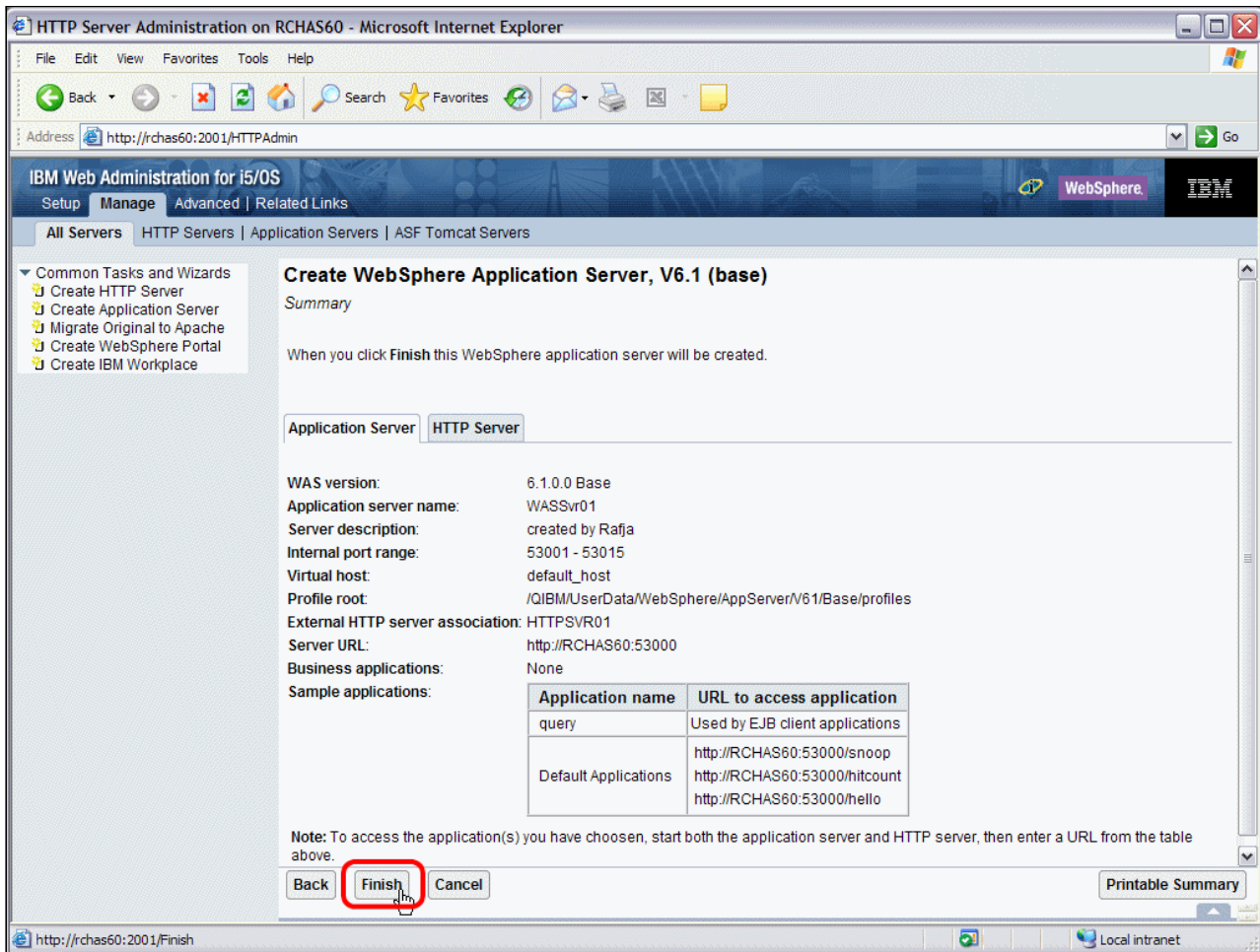

Figure 4-16 IBM Web Administration for i5/OS - Application Server summary

13. The HTTP Server tab in Figure 4-17 on page 105 summarizes the HTTP server instance parameters. After you confirm that all of the parameters are correct, click **Finish**.

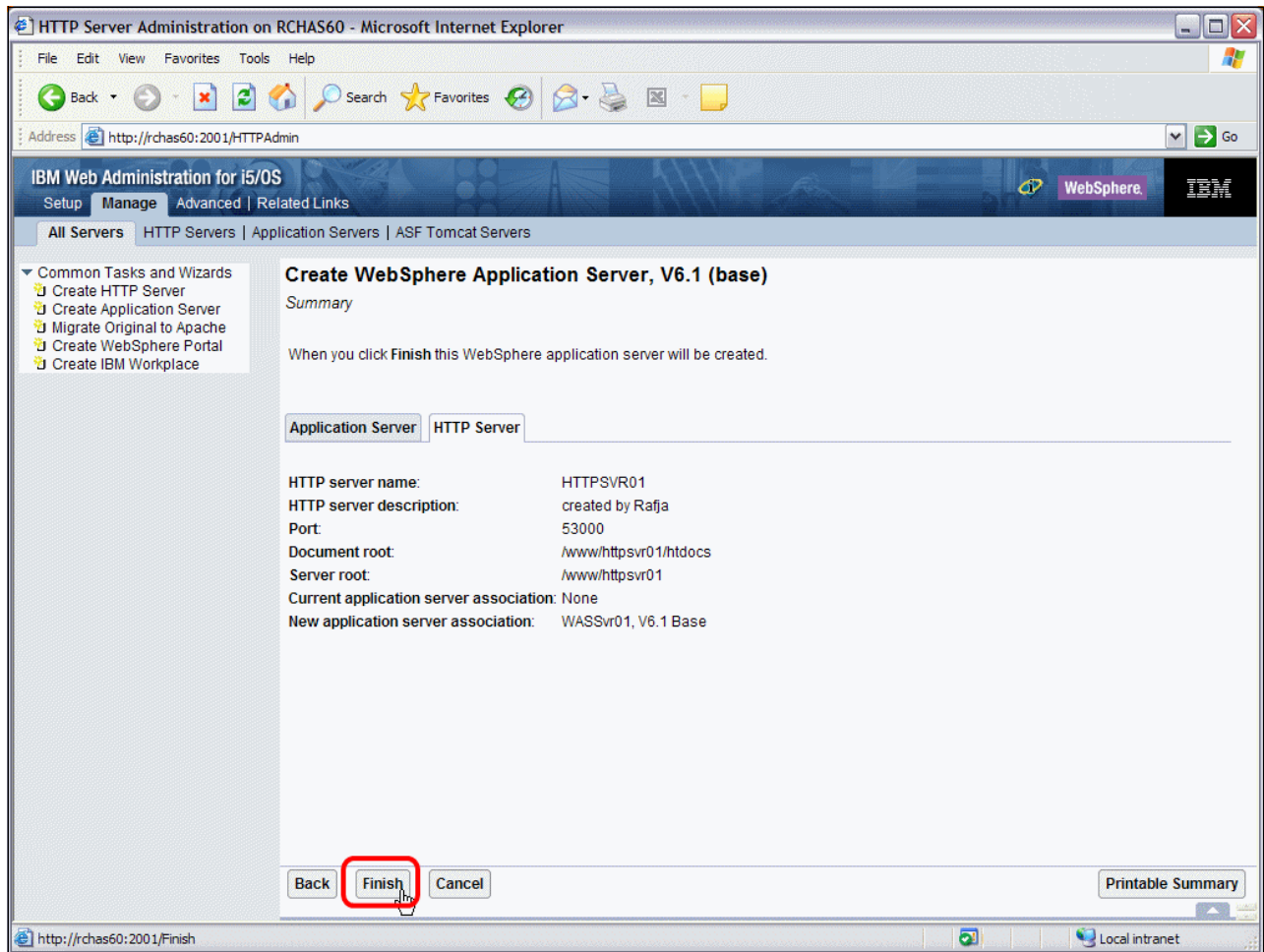

Figure 4-17 IBM Web Administration for i5/OS - HTTP Server summary

The process of creating the application server profile can take up to approximately 15 minutes, depending on the current load on your server as well as the configuration of your hardware. Remember that from the i5/OS perspective the process is very IFS intensive.

Figure 4-18 shows the stage where the application server profile is still being created.

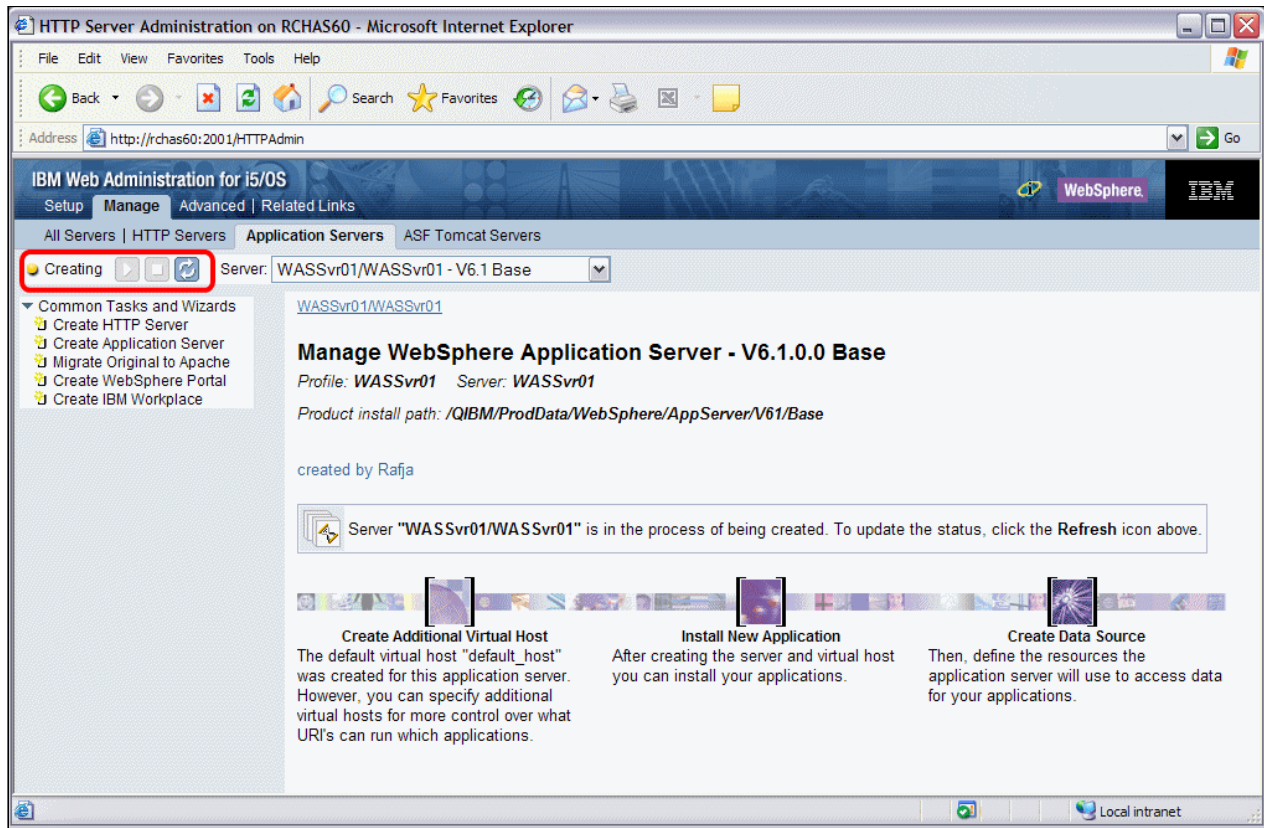

Figure 4-18 IBM Web Administration for i5/OS - Creating the application server profile

After the application server status is stopped (Figure 4-19 on page 107) it means that the profile was created.

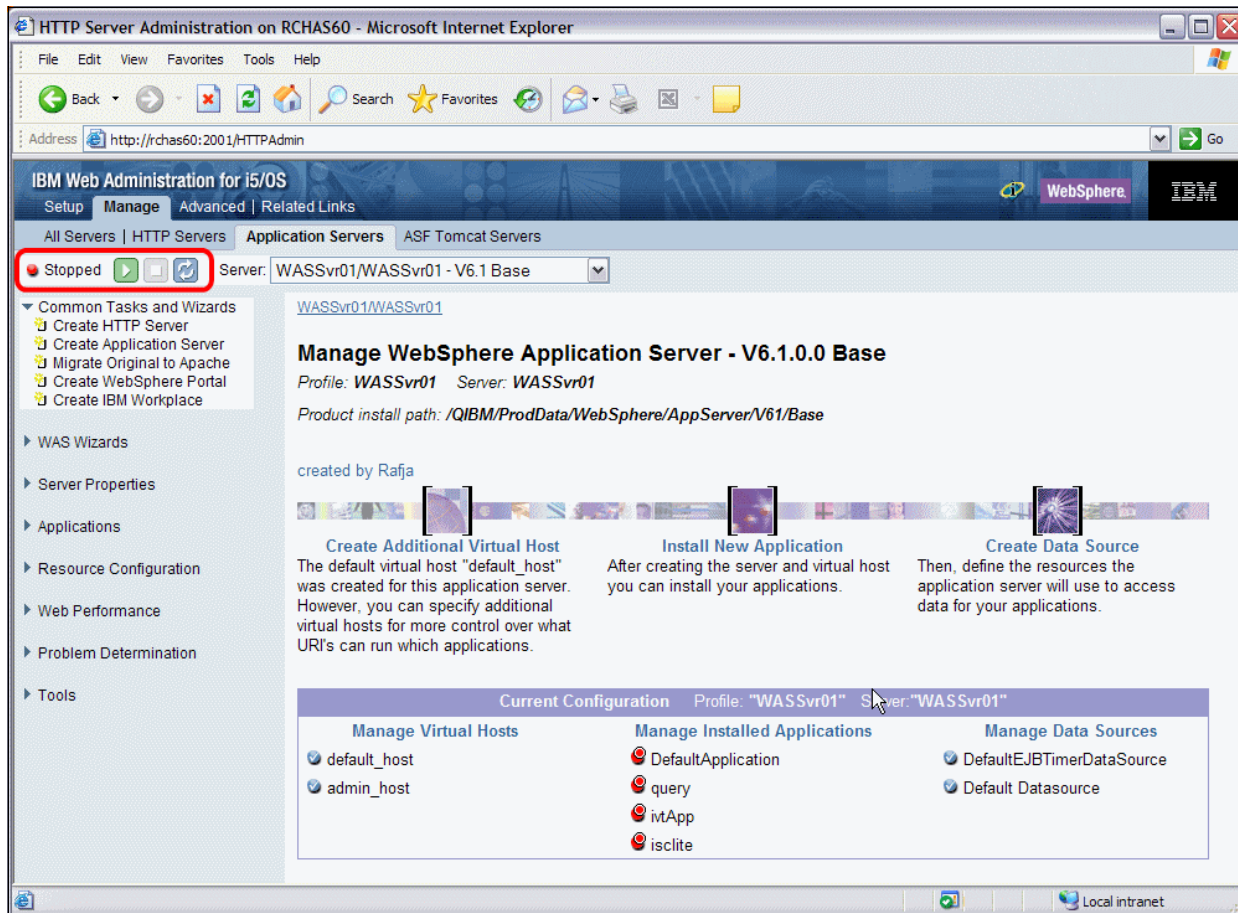

Figure 4-19 IBM Web Administration for i5/OS - WebSphere Application Server profile created

In this section, we walked you through the complete process of creating the WebSphere Application Server profile and creating the HTTP Server instance. Both servers were also associated by the wizard to allow the HTTP Server to serve static Web content and redirect dynamic requests to the application server.

### 4.2.3 Starting an application server

In this section, we describe two ways that you can start a WebSphere Application Server profile.

#### Starting an application server using the Qshell environment

In this example, we describe how to start the application server from the Qshell command line. The `startServer` command reads the configuration file for the specified application server and starts the server.

Table 4-3 lists the parameter that is usually required to start the application server.

Table 4-3 The `startServer` parameters

Parameter name	Sample value	Description
-profileName	WASSvr01	Specifies the name of the profile to start and defines the profile of the application server process in a multi-profile installation.

Complete the following steps to start the application server:

1. Start a 5250 emulator session and sign on.
2. Start a QShell session with the STRQSH command.
3. Change to the core binary product files location:

```
cd /QIBM/ProdData/WebSphere/AppServer/V61/Base/bin
```

**Note:** The default location of the core binary product files can change depending on the application server edition, type, or custom settings. In our examples, we assume that WebSphere Application Server V6.1 Base is installed in the default location.

4. Run the startServer script with the parameters that we specified in Table 4-3 on page 107.

```
startServer -profileName WASSvr01
```

After the application server is started, you can see output messages in the Qshell session as shown in Example 4-3.

*Example 4-3 Starting the application server*

---

```
> startServer -profileName WASSvr01
CPC1221: Job 068195/QEJBSVR/WASSVR01 submitted to job queue QWASJOBQ in
library QWAS61.
CWNATV00I: Application server WASSvr01 in profile WASSvr01 has started and is
ready to accept connections on admin port 53002.
$
===>
```

---

The command finished successfully, and the application server is ready to serve deployed applications.

The important message in Example 4-3 is the port on which the administration console is listening. In this case, the administration console is ready to accept connections on port 53002.

## Starting an application server using IBM Web Administration for i5/OS

In this section, we describe how to start the application server profile using IBM Web Administration for i5/OS. We suggest this method for users who do not feel comfortable with using Qshell commands.

Complete the following steps to start an application server profile using IBM Web Administration for i5/OS:

1. Open and login to IBM Web Administration for i5/OS as described in 4.2.1, “Starting IBM Web Administration for i5/OS” on page 89.
2. Click the **IBM Web Administration for i5/OS** link.

3. IBM Web Administration for i5/OS contains a set of tabs that allow you to work with different subsets of information. Click the **Manage** tab, as shown in Figure 4-20, to manage the servers that are running on your system.

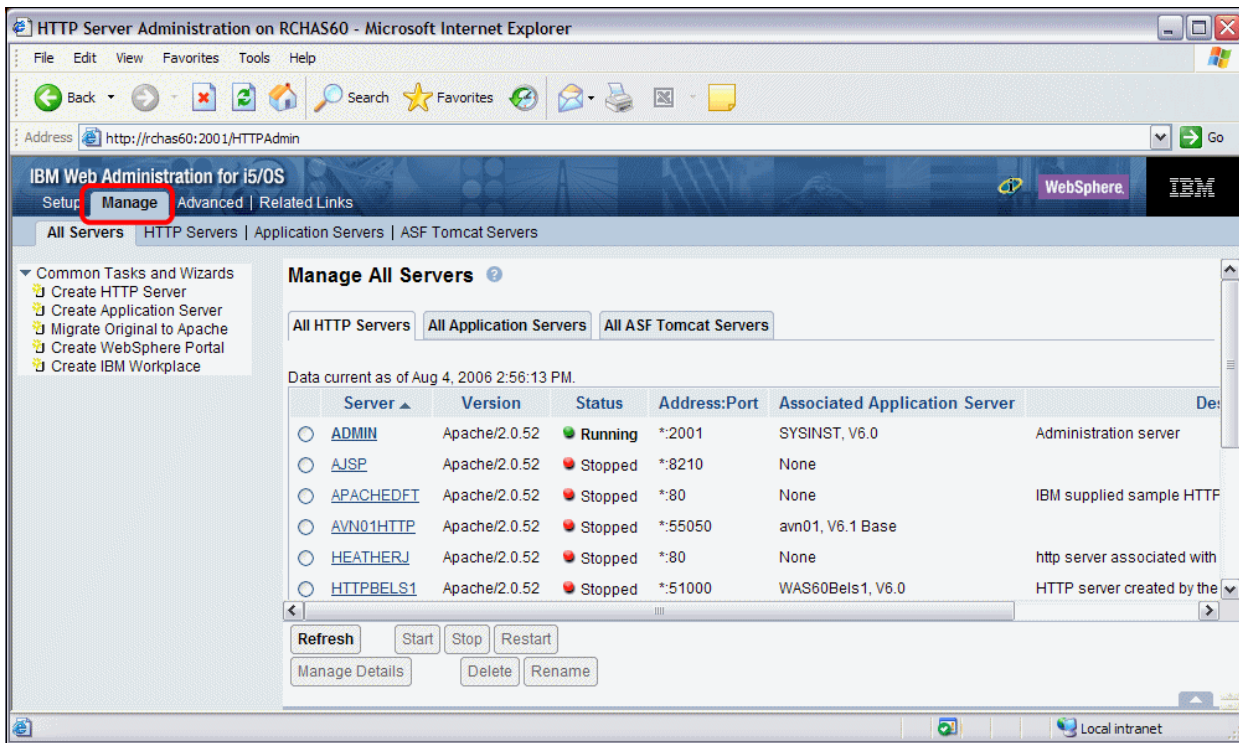

Figure 4-20 IBM Web Administration for i5/OS - Common Tasks and Wizards

4. Click the **All Application Servers** tab, as shown in Figure 4-21 on page 110.

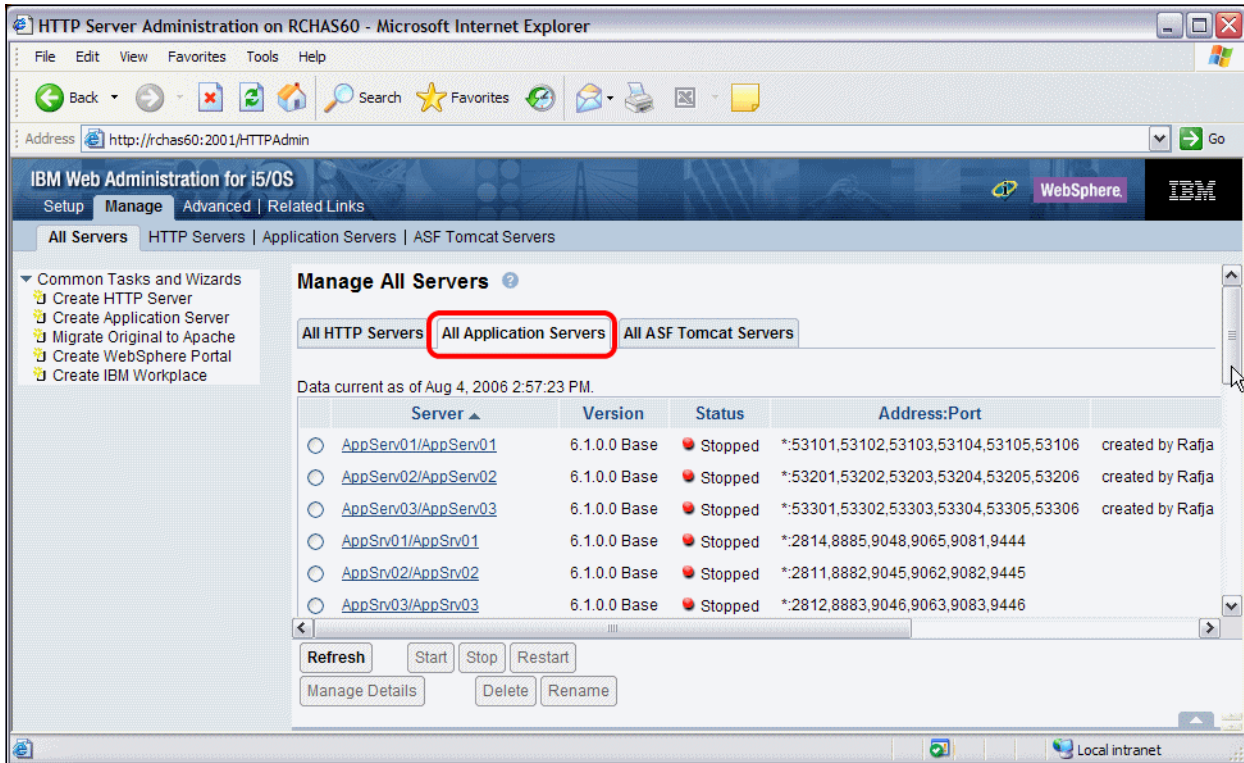

Figure 4-21 IBM Web Administration for i5/OS - List of application servers defined

5. Select the profile you want to work with, as shown in Figure 4-22. Click **Start** to start the application server profile.

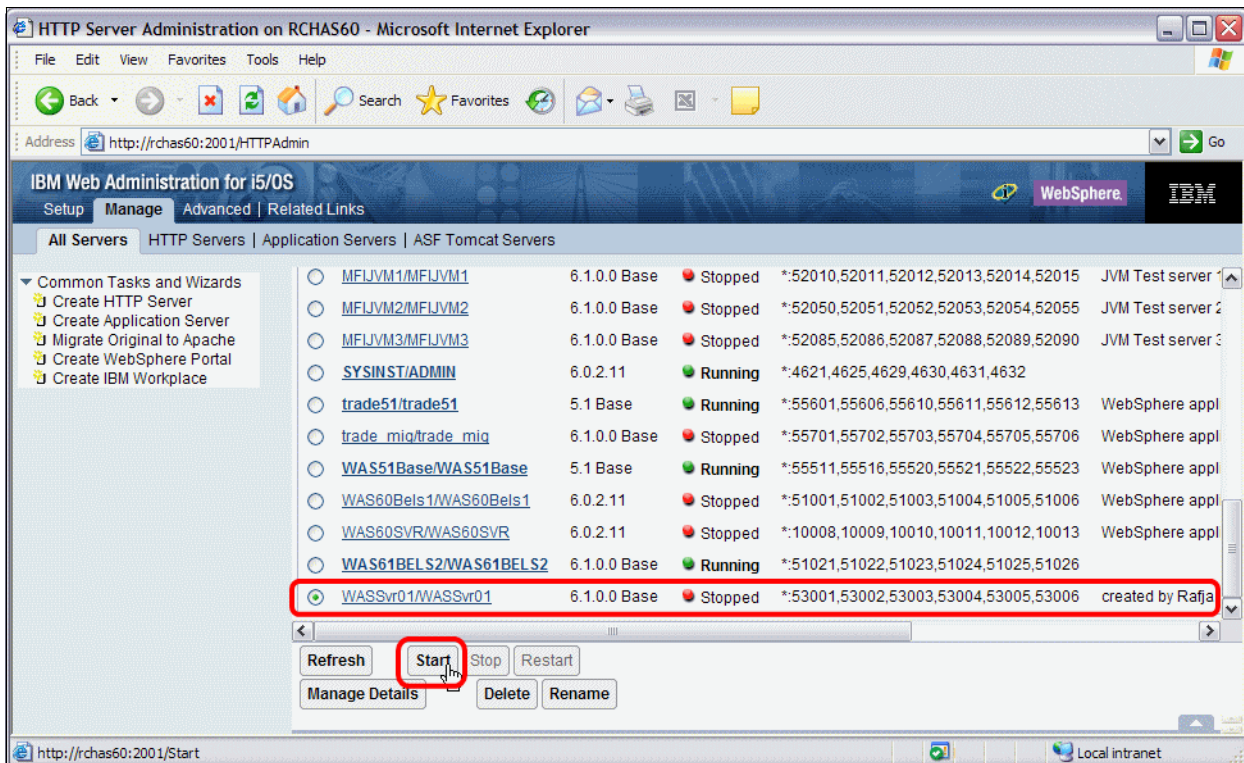

Figure 4-22 IBM Web Administration for i5/OS - Starting the application server profile

- Before you start the application server profile, the wizard asks if you also want to start the HTTP server instance associated with this application server profile.  
Leave the default selection because the wizard starts both the application server profile and the HTTP Server instance. Click **Start** as shown in Figure 4-23.

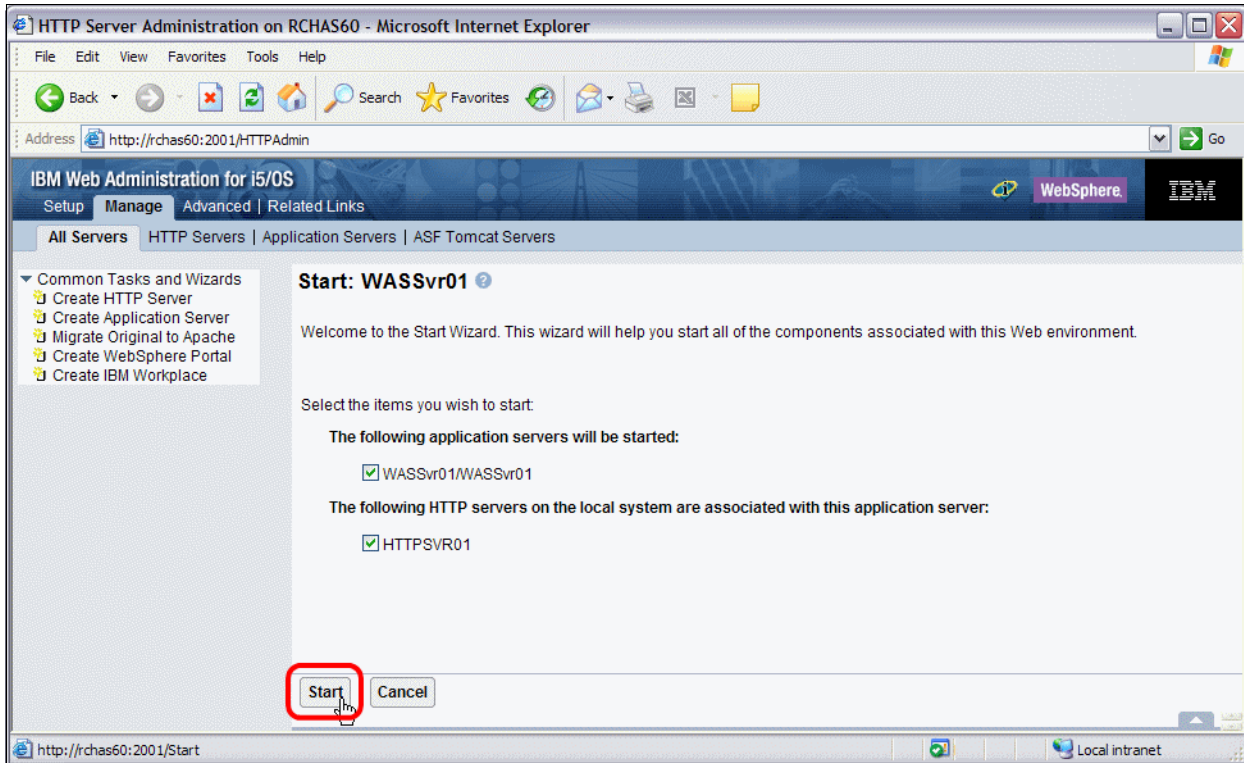

Figure 4-23 IBM Web Administration for i5/OS - Choosing profiles to start

- The amount of time that the application server profile takes to start depends on server load, configuration, and so on. The current status of the process is visible in the application server profile entry shown in Figure 4-24 on page 112. Click the **Refresh** button periodically to check the current status of the startup process.

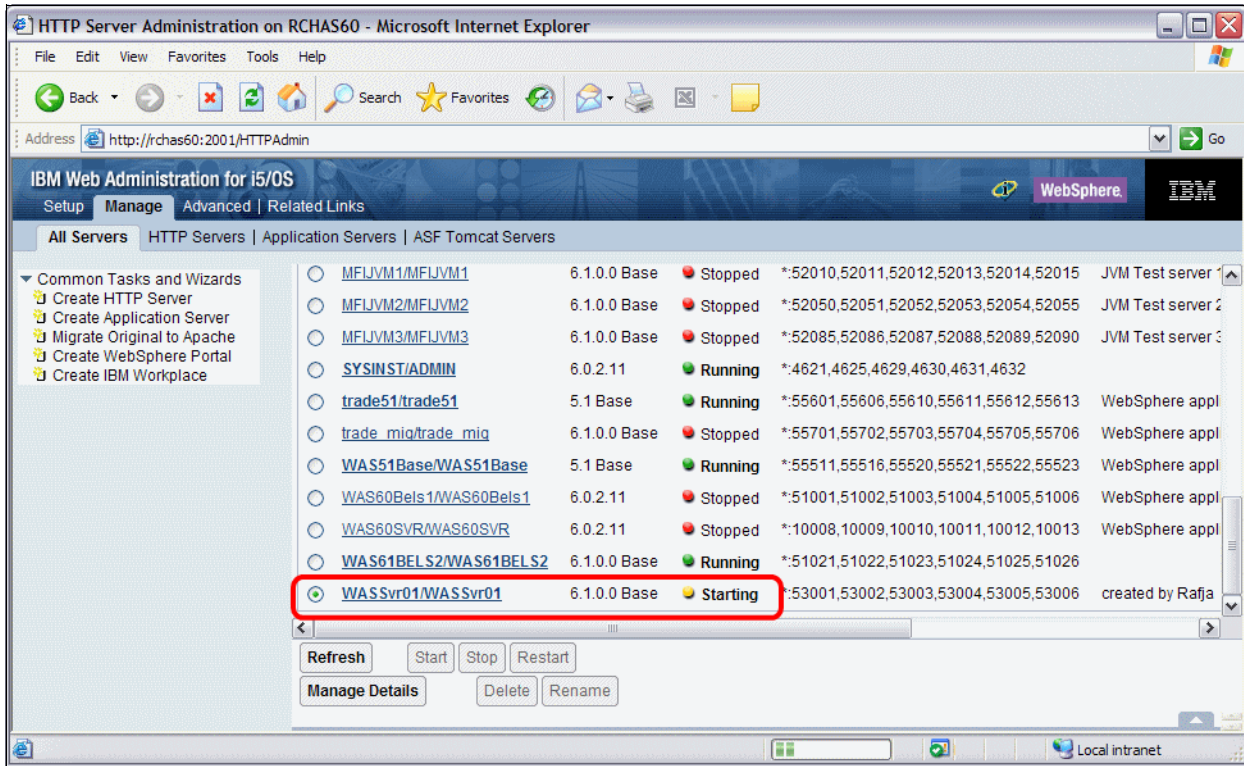

Figure 4-24 IBM Web Administration for i5/OS - application server profile starting up

8. After the status is *Running*, click the application server's name as shown in Figure 4-25.

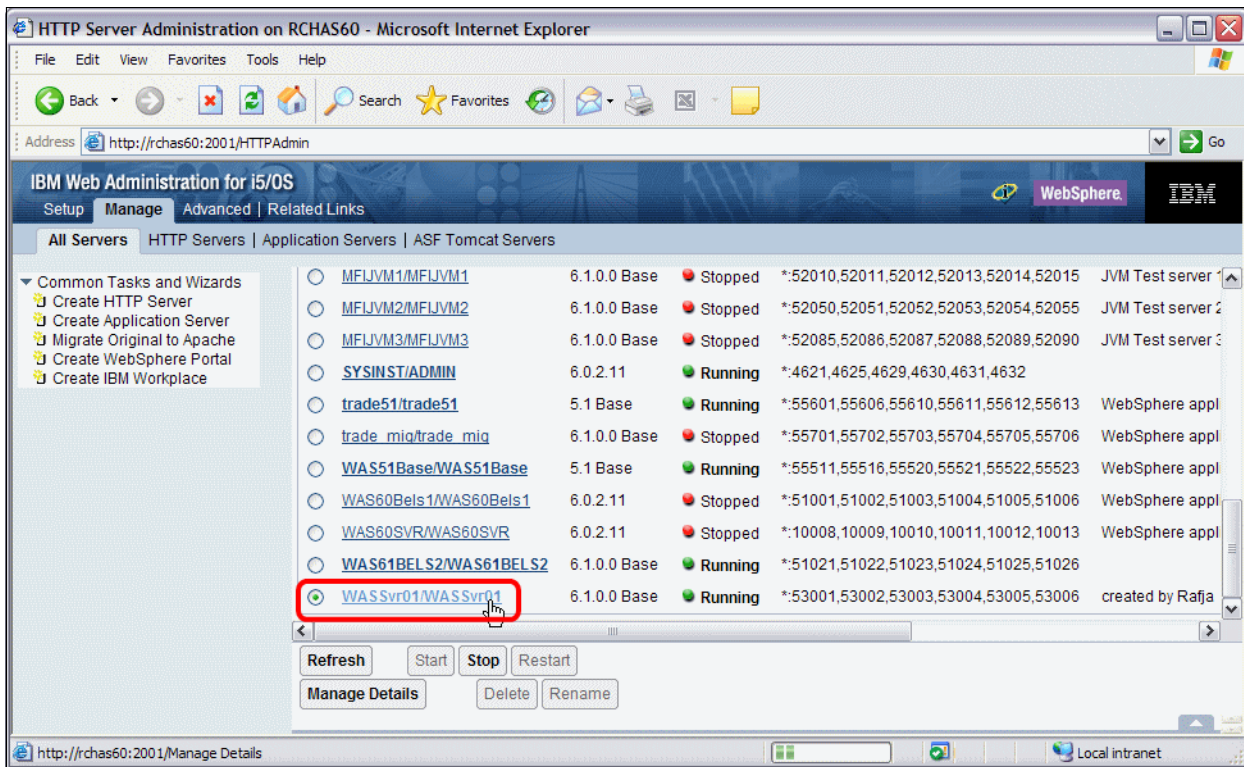

Figure 4-25 IBM Web Administration for i5/OS - Application server profile link

- Figure 4-26 shows the WebSphere profile's home page, which is a unique feature of the implementation on the i5/OS operating system. Within this interface, you can perform the most common administrative tasks, such as starting and stopping the profile, installing applications, working with logs, and so on. We strongly encourage you to start with this simplified console first.

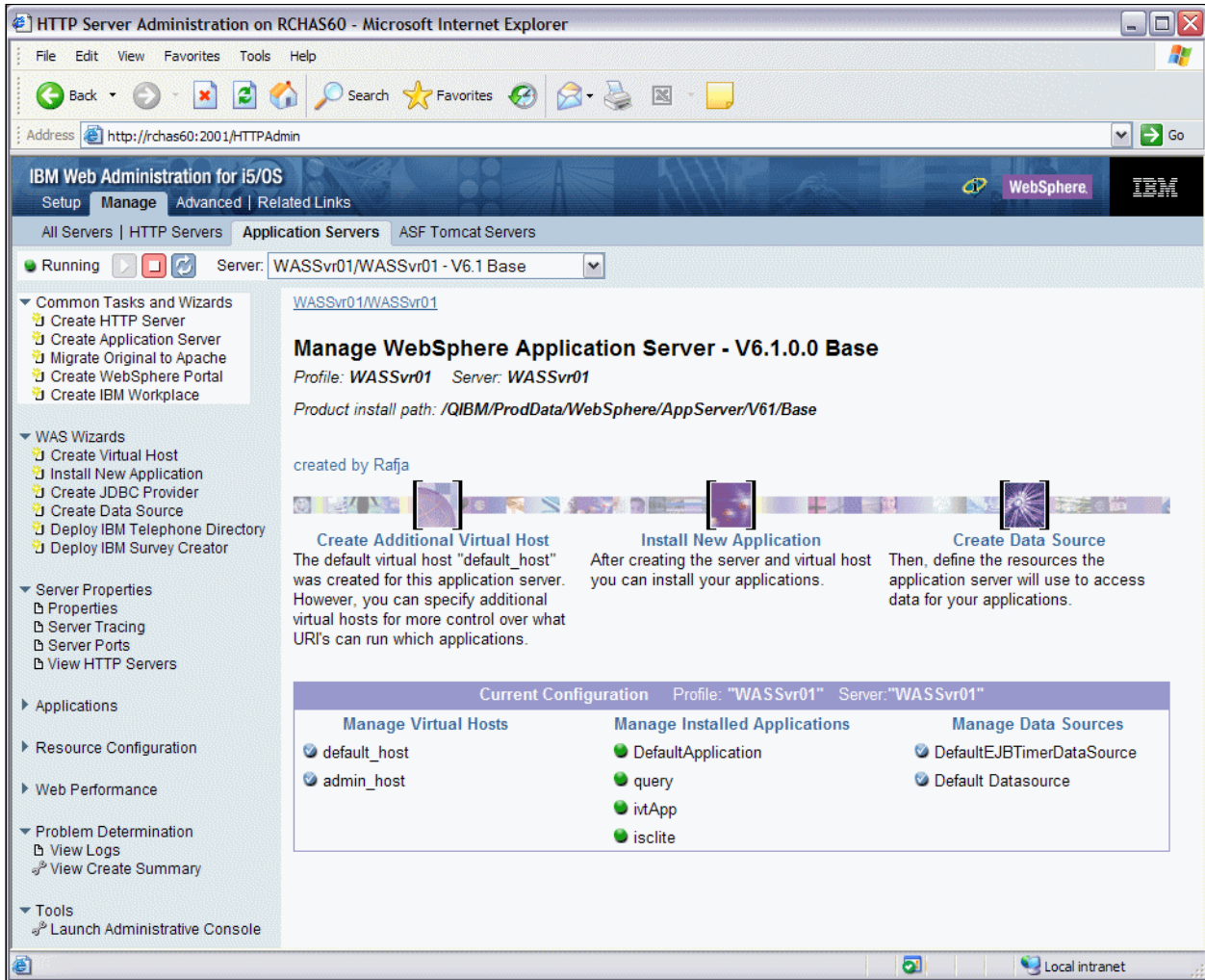

Figure 4-26 IBM Web Administration for i5/OS - embedded WebSphere administrative console

## 4.2.4 Stopping an application server

In this section, we describe two ways that you can stop a WebSphere Application Server profile.

### Stopping an application server using the Qshell environment

Here, we describe how to stop the application server from the Qshell command line. The `stopServer` command reads the configuration files for the specified server process and does not return control to the command line until the server completes the shut down process.

Table 4-4 on page 114 lists the parameter that is used to stop the application server.

Table 4-4 The stopServer parameters

Parameter name	Sample value	Description
-profileName	WASSvr01	Specifies the name of the profile to stop and defines the profile of the application server process in a multi-profile installation.

Complete the following steps to stop the application server:

1. Start a 5250 emulator session and sign on.
2. Start a QShell session with the STRQSH command.
3. Change to the core binary product files location:

```
cd /QIBM/ProdData/WebSphere/AppServer/V61/Base/bin
```

**Note:** The default location of the core binary product files can change depending on the application server edition, type, or custom settings. In our examples, we assume that WebSphere Application Server V6.1 Base is installed in the default location.

4. Run the stopServer script with the parameters that we specified in Table 4-4.

```
stopServer -profileName WASSvr01
```

After the application server is stopped, you will see messages similar to those in Example 4-4 in the Qshell session.

*Example 4-4 Stopping the application server process*

---

```
> stopServer WASSvr01 -profileName WASSvr01
  ADMU0116I: Tool information is being logged in file
            /QIBM/UserData/WebSphere/AppServer/V61/Base/profiles/WASSvr01/logs
            /WASSvr01/stopServer.log
  ADMU0128I: Starting tool with the WASSvr01 profile
  ADMU3100I: Reading configuration for server: WASSvr01
  ADMU3201I: Server stop request issued. Waiting for stop status.
  ADMU4000I: Server WASSvr01 stop completed.
$
===>
```

---

The command finished successfully, and the application server process was stopped.

### Stopping an application server using IBM Web Administration for i5/OS

In this section, we describe how to stop the application server profile using IBM Web Administration for i5/OS. We suggest this method for users who do not feel comfortable with using Qshell commands.

Complete the following steps to stop an application server profile using IBM Web Administration for i5/OS:

1. Open and login to IBM Web Administration for i5/OS as described in 4.2.1, “Starting IBM Web Administration for i5/OS” on page 89

2. Click the **IBM Web Administration for i5/OS** link. You will see a window as shown in Figure 4-27.
3. IBM Web Administration for i5/OS contains a set of tabs that allows you to work with different subsets of information. Click the **Manage** tab, as shown in Figure 4-27, to manage the servers that are running on your system.

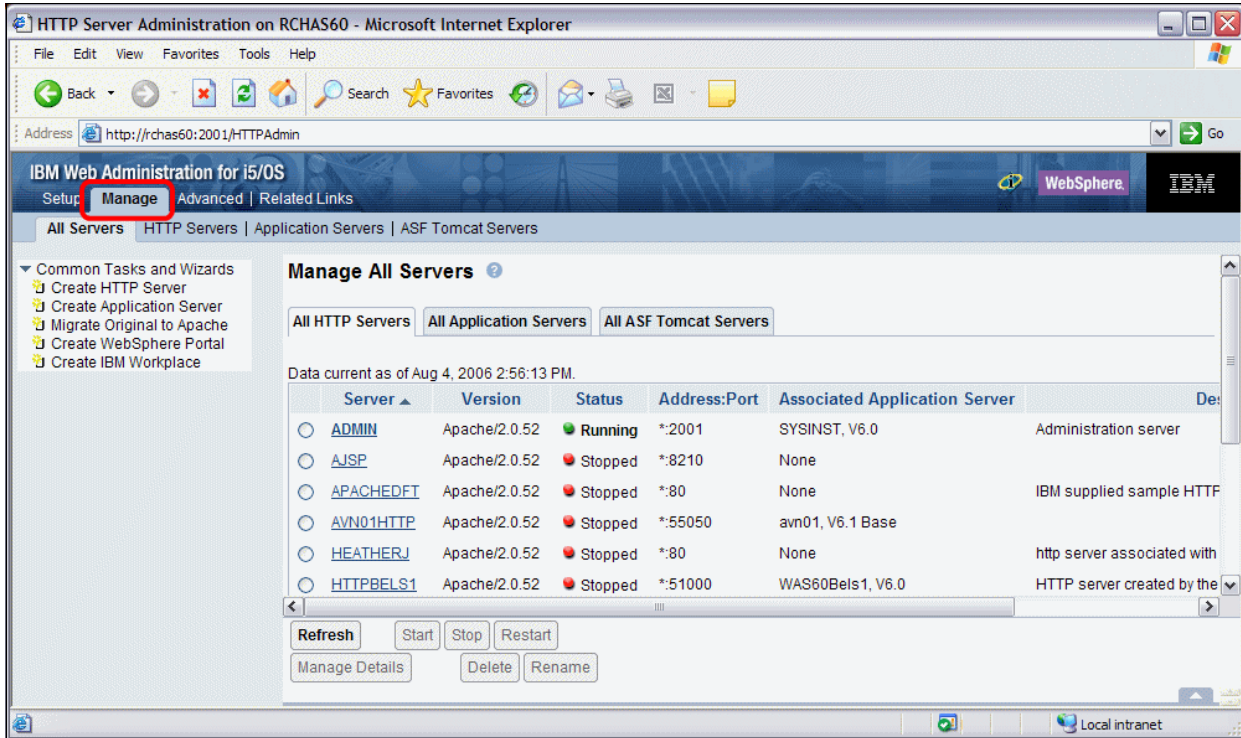

Figure 4-27 IBM Web Administration for i5/OS - Common Tasks and Wizards

4. IBM Web Administration for i5/OS allows you to work with HTTP servers, WebSphere Application Server, and ASF Tomcat server. Click the **All Application Servers** tab as shown in Figure 4-28 on page 116.

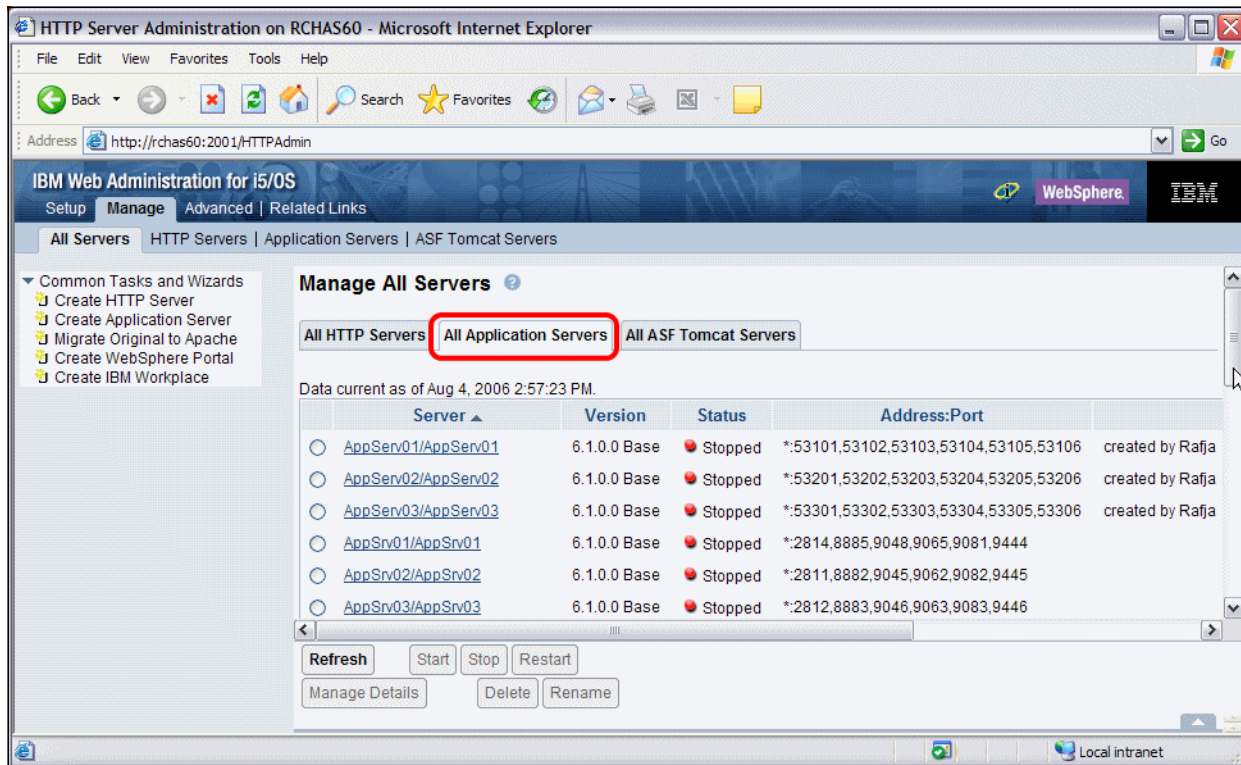

Figure 4-28 IBM Web Administration for i5/OS - List of application servers defined

- As shown in Figure 4-29 on page 117 the wizard shows all WebSphere profiles on the system. Select the profile you want to work with. Click **Stop** to stop the application server profile.

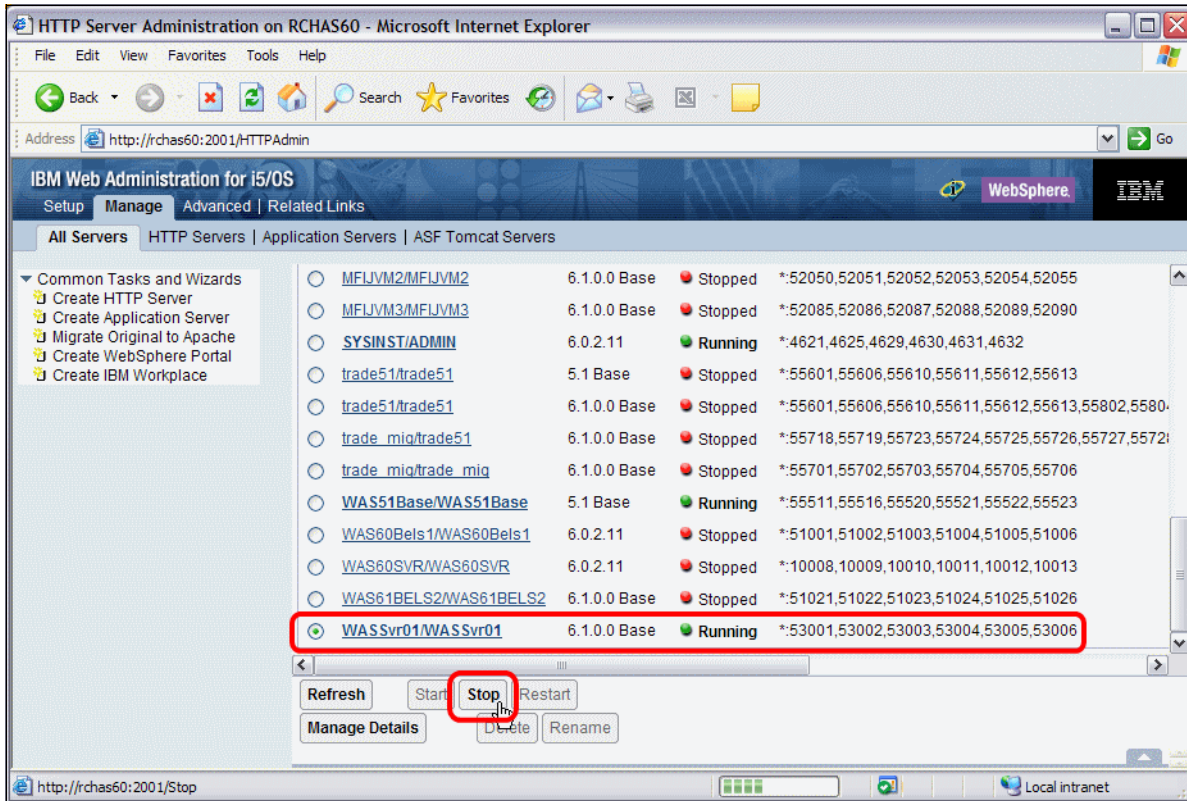

Figure 4-29 IBM Web Administration for i5/OS - Stopping the application server profile

Before the application server profile is stopped, the wizard gives you the option of stopping just the application server and stopping the HTTP server instance that is associated with the application server profile, if it is running.

6. Select whether to stop the HTTP server instance as shown in Figure 4-30. Click **Stop**.

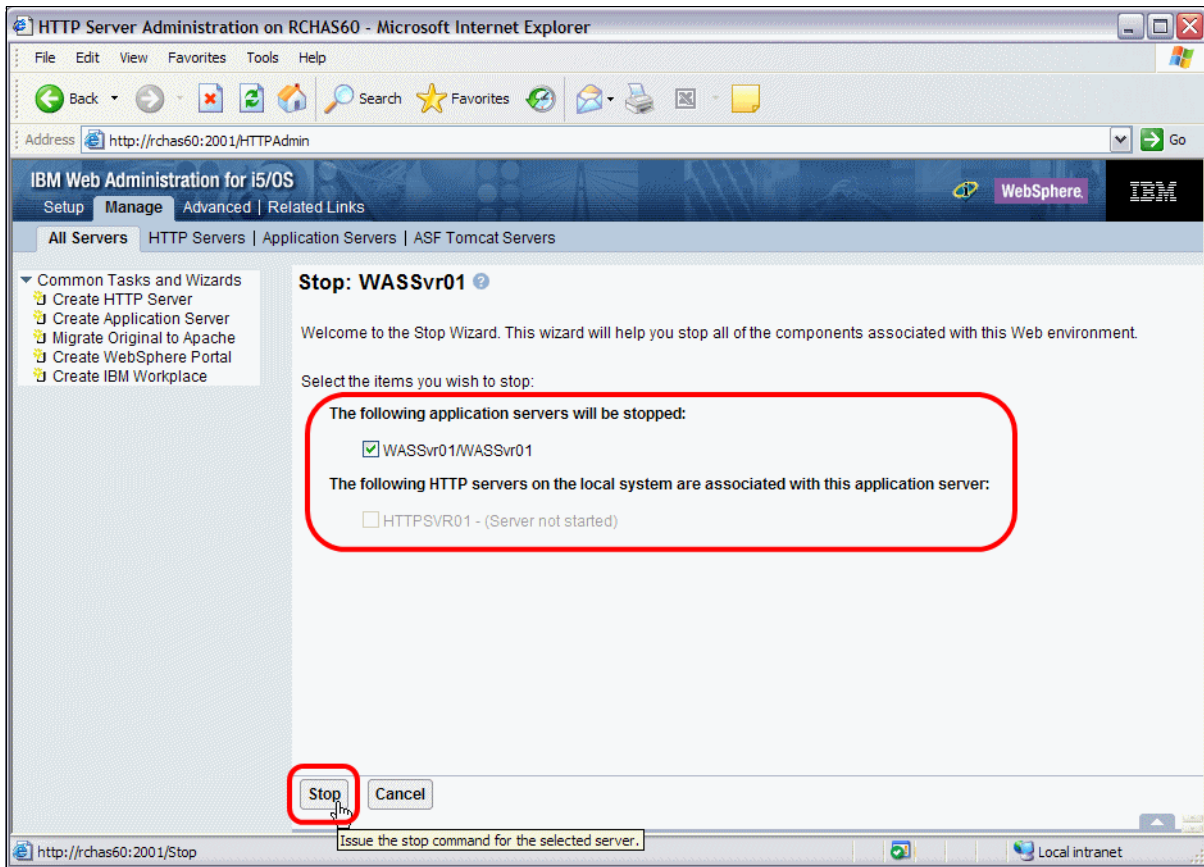

Figure 4-30 IBM Web Administration for i5/OS - Choosing items to stop

The time required to stop the application server profile depends on the current server load, among other factors. The current status of the process is visible in the application server profile entry as shown in Figure 4-31 on page 119.

7. Click the **Refresh** button periodically to get the latest status of the server stop process.

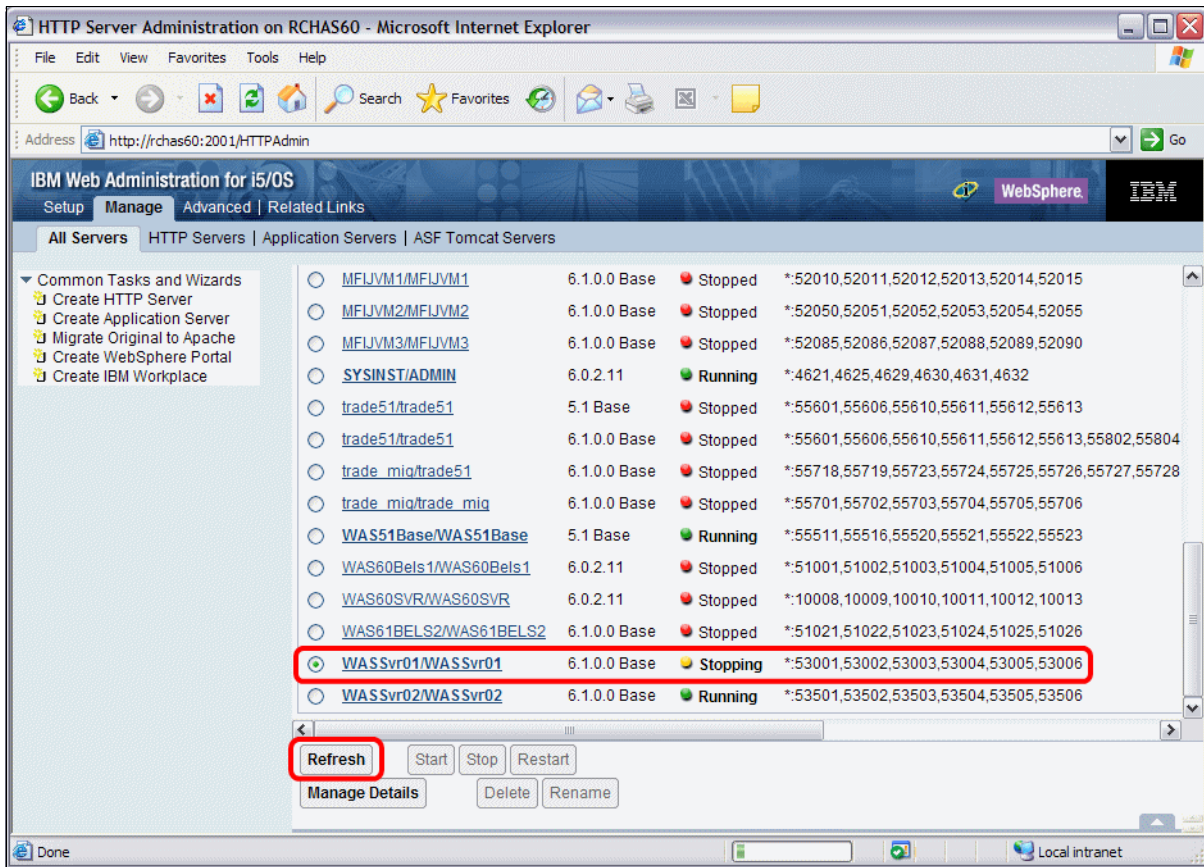

Figure 4-31 IBM Web Administration for i5/OS - Stopping the application server profile

When the profile stops, you can see its status as *Stopped*, as shown in Figure 4-32 on page 120.

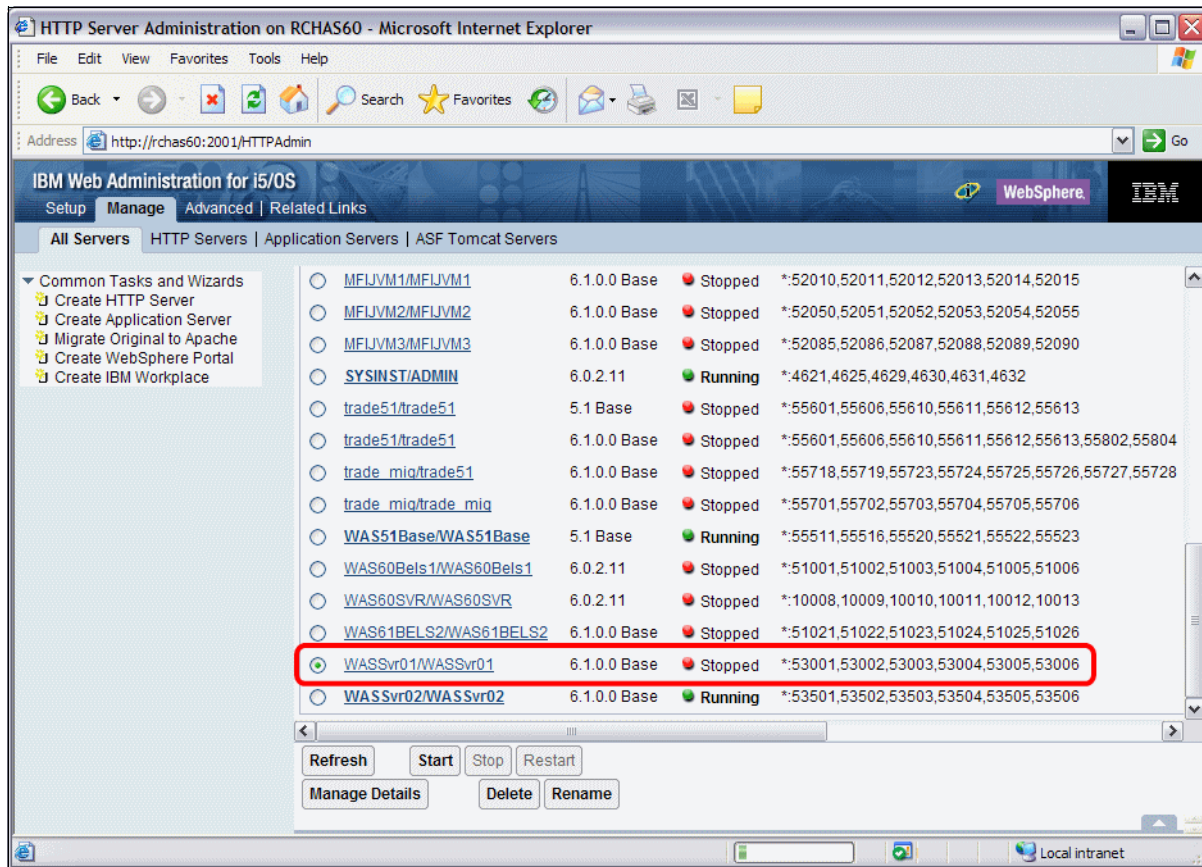

Figure 4-32 IBM Web Administration for i5/OS - Application server profile stopped

## 4.2.5 Running QShell scripts from the profile's home directory

In addition to running the QShell scripts from the WebSphere core binary product directory, you can run the same scripts from a profile's home directory, for example, if we use the default location for WebSphere Application Server Base user directory and the application server called WASSvr01, the home directory for this application server is:

```
/qibm/userdata/websphere/appserver/v61/base/profiles/wassvr01/
```

The advantage of running the QShell script from the profile's home directory is that you do not need to specify the `-profileName` parameter. The value for this parameter defaults to the profile from which home directory you are running a script. As an example, we start the WASSvr01 profile from its home directory using the following two commands:

```
cd /qibm/userdata/websphere/appserver/v61/base/profiles/wassvr01/bin
startServer
```

But it is still possible to manage other profiles from this profile home directory. Just use the `-profileName` parameter and specify other profile's name, for example:

```
cd /qibm/userdata/websphere/appserver/v61/base/profiles/wassvr01/bin
startServer -profileName default
```

## 4.2.6 Accessing the WebSphere Administrative Console

The WebSphere Administrative Console is the GUI interface for managing a WebSphere Application Server. The WebSphere Administrative Console is implemented as a J2EE application that runs within the server that it manages. Consequently, the server must be running before you can use the WebSphere Administrative Console. In this section, we provide instructions for accessing the WebSphere Administrative Console.

### Accessing the WebSphere Administrative Console directly

Perform the following steps to access the WebSphere Administrative Console:

1. Open a Web browser.

**Important:** Enable cookies in the Web browser. We also recommend that you enable JavaScript™ so that all of the features of the administrative console are available to you.

2. Enter the administrative console URL:

```
http://<your_fully_qualified_server_name>:<port_number>/ibm/console
```

In the administrative console URL:

- <your\_fully\_qualified\_server\_name> is the fully qualified host name for the machine that contains the administrative server.
- <port\_number> is the administrative console port number, which relates to the WC\_adminhost\_port.

There are ways to determine the administrative console port if you are unsure. See 4.2.11, “Discovering TCP/IP ports assigned to the profile” on page 151 or “Displaying TCP/IP ports assigned to the profile using IBM Web Administration for i5/OS” on page 152.

The administrative console login window (Figure 4-33 on page 122) is displayed.

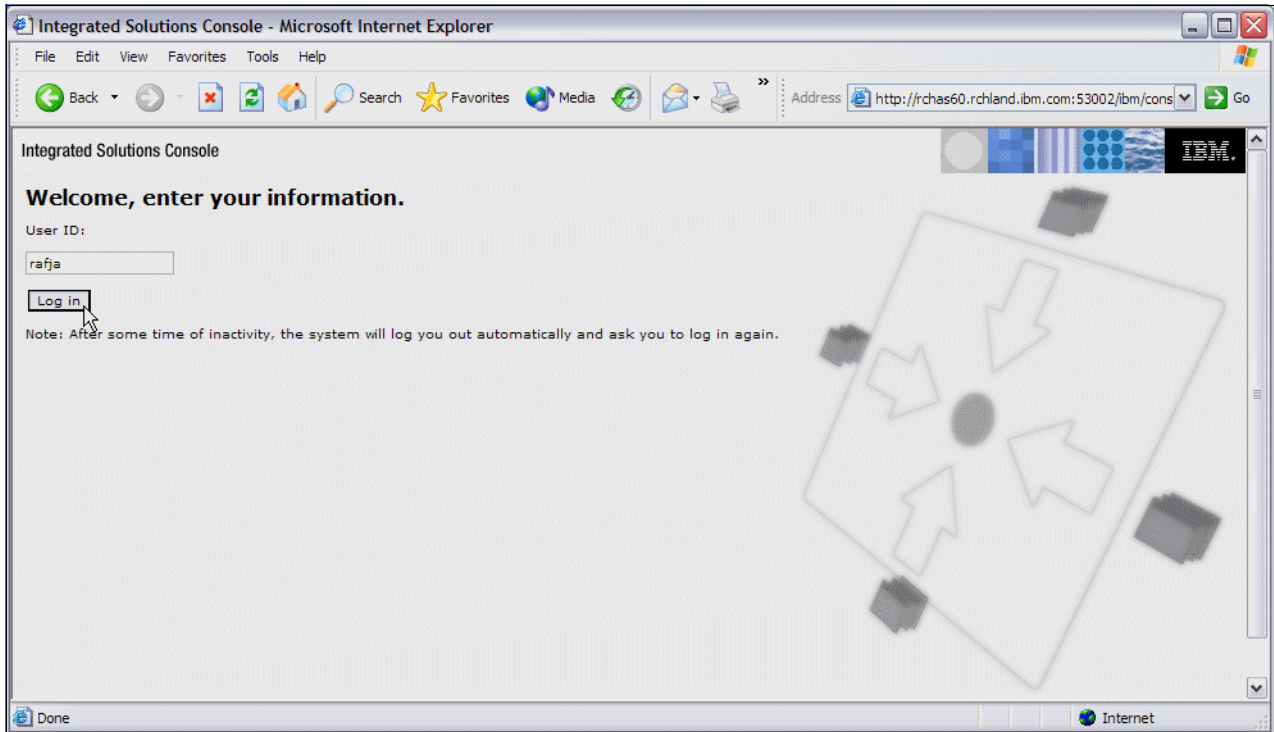

Figure 4-33 WebSphere Application Server console - Login window

3. Log in to the administrative console, and click **OK**.

Enter your user name or user ID. After successful login, the administrative console is displayed as shown in Figure 4-34. However, when the WebSphere security is turned off, you can enter any name in the User ID field. This name is used to recognize changes made by different users. There is no authentication check.

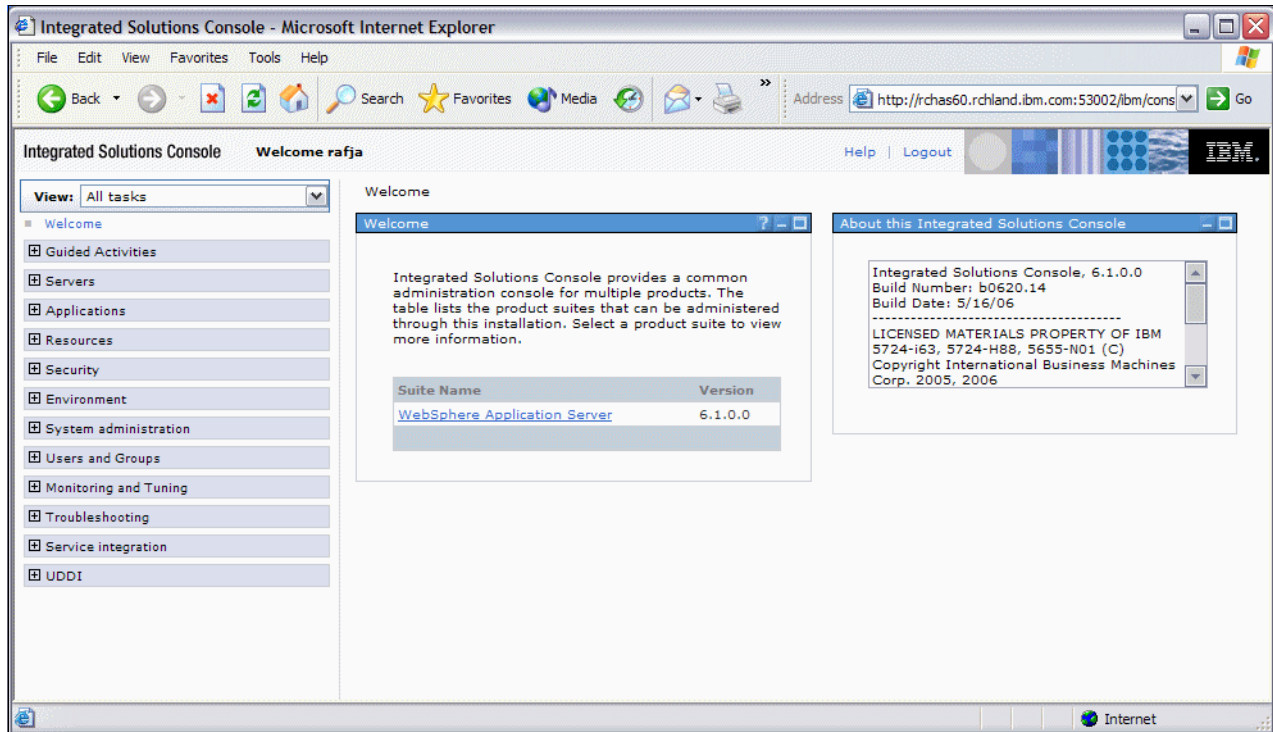

Figure 4-34 WebSphere administrative console - Welcome window

## Accessing the WebSphere administrative console using IBM Web Administration for i5/OS

In this section, we describe how to access the WebSphere Administrative Console from IBM Web Administration for i5/OS.

**Important:** To work with IBM Web Administration for i5/OS, start the application first. See 4.2.1, “Starting IBM Web Administration for i5/OS” on page 89 for details about how to start this application.

Perform the following steps to access the WebSphere administrative console using IBM Web Administration for i5/OS:

1. Open and login to IBM Web Administration for i5/OS as described in 4.2.1, “Starting IBM Web Administration for i5/OS” on page 89.
2. Click the **IBM Web Administration for i5/OS** link. A window, Figure 4-35 on page 124, is displayed.
3. Click the **All Application Servers** tab.

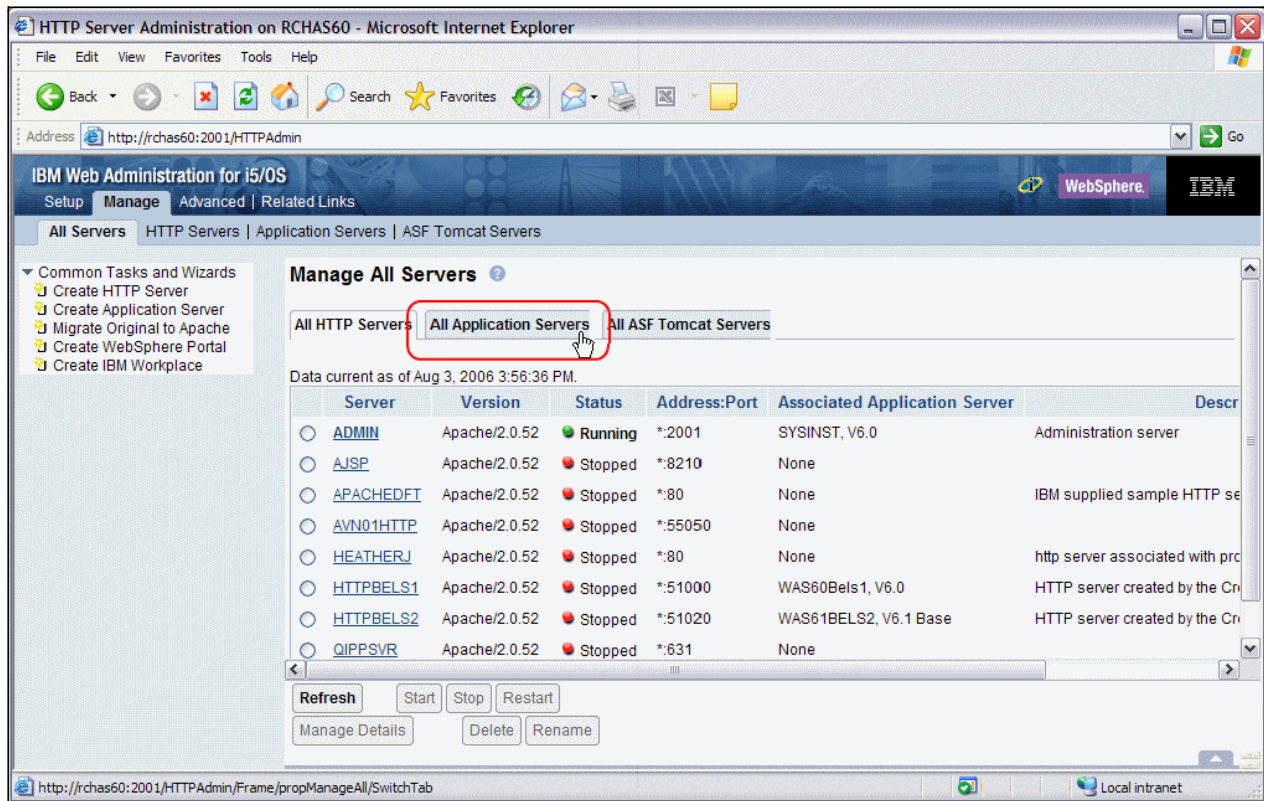

Figure 4-35 IBM Web Administration for i5/OS - All HTTP Servers tab

4. Choose the application server profile you want to work with. Click the link, as shown in Figure 4-36 on page 125.

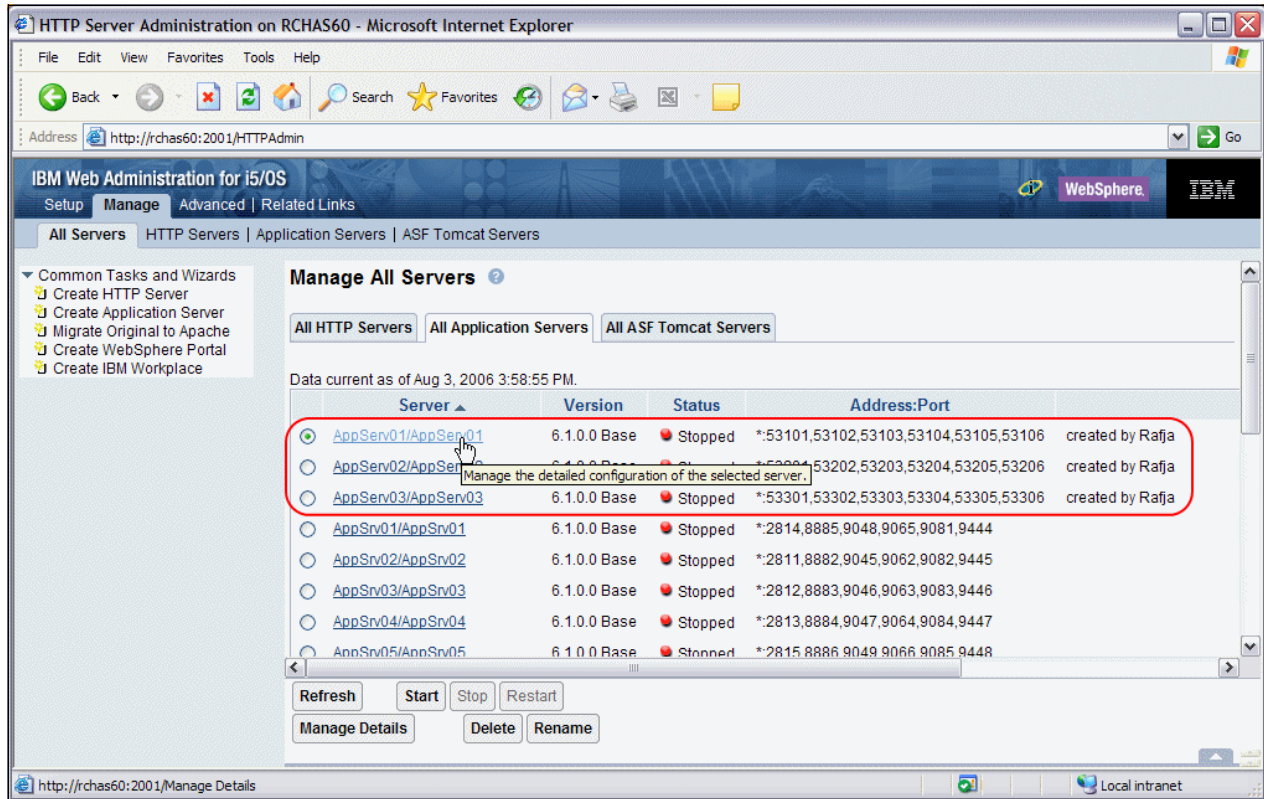

Figure 4-36 IBM Web Administration for i5/OS - All Application Servers tab

- When the application server home page opens, click the **Launch Administrative Console** link, as shown in Figure 4-37 on page 126.

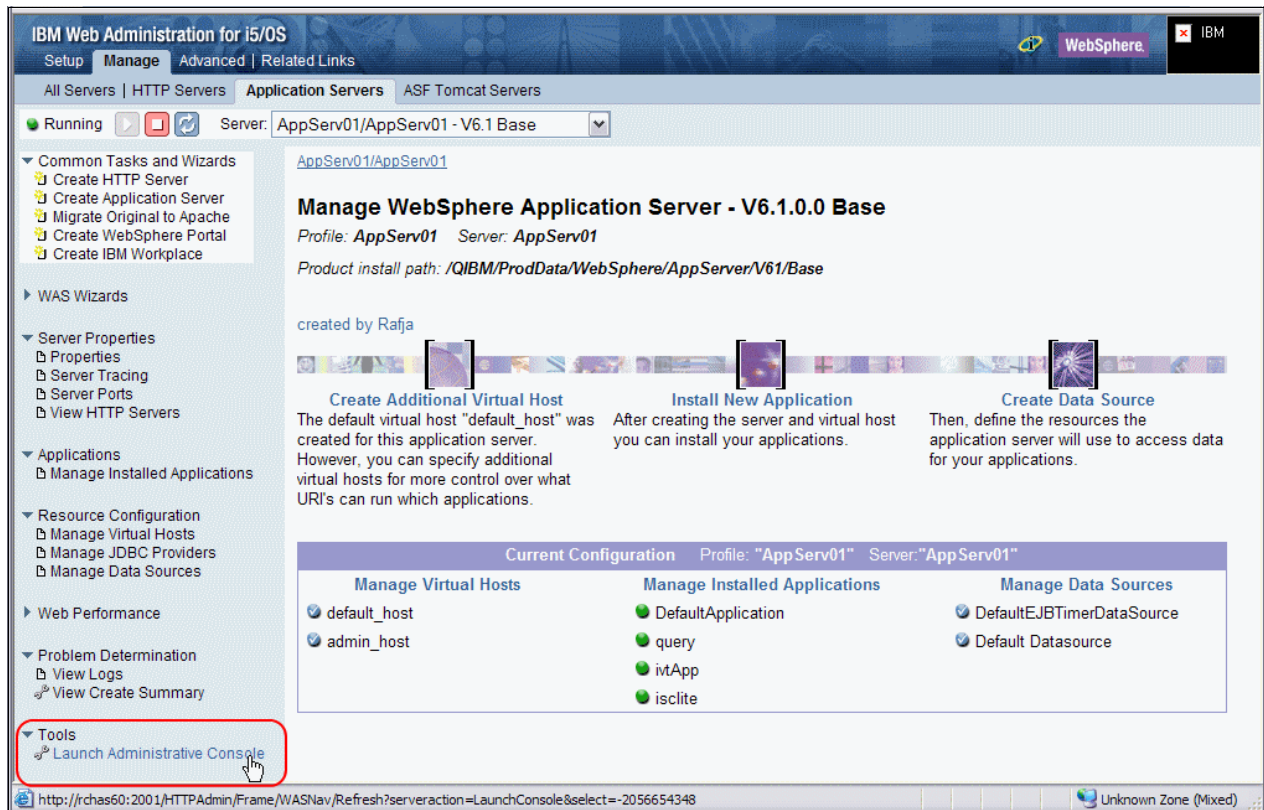

Figure 4-37 IBM Web Administration for i5/OS - Application Server's details

A new Web browser window opens, and the WebSphere Administrative Console is loaded into it.

## 4.2.7 Listing the existing WebSphere profiles

This example shows you how to list the WebSphere profiles that are defined on the system. To do this, you can take advantage of one of the most versatile commands - `manageprofiles`.

Complete the following steps to list the WebSphere profiles on the system:

1. Start a 5250 emulator session and sign on.
2. Start a QShell session with the STRQSH command.
3. Change to the core binary product files location:

```
cd /QIBM/ProdData/WebSphere/AppServer/V61/Base/bin
```

**Note:** The default location of the core binary product files can change depending on the application server edition, type, or custom settings. In our examples, we assume that WebSphere Application Server V6.1 Base is installed in the default location.

4. Run the `manageprofiles` script with the `-listProfiles` parameter:

```
manageprofiles -listProfiles
```

The command lists the existing profiles as shown in Example 4-5 on page 127.

*Example 4-5 The list of WebSphere profiles defined*

```
> manageprofiles -listProfiles
  [default, AppSvr01]
$
===>
```

The manageprofiles script allows you to list all of the WebSphere profiles that are defined within the installed product's scope, for instance, if you have several WebSphere Application Server products installed in different IFS locations, you have to run the script separately for each installation.

Another way to determine what profiles are defined is to examine the profileregistry.xml file. This file is located under the UserData directory structure. For the default WebSphere Application Server V6.1 Base location, profileregistry.xml is located in the /QIBM/UserData/WebSphere/AppServer/V61/Base/profileRegistry directory.

Figure 4-38 is an example of the contents of the profileregistry.xml file.

```
<?xml version="1.0" encoding="UTF-8" ?>
- <profiles>
  <profile isAReservationTicket="false" isDefault="true" name="default"
  path="/QIBM/UserData/WebSphere/AppServer/V61/Base/profiles/default"
  template="/QIBM/ProdData/WebSphere/AppServer/V61/Base/profileTemplates/default"
  />
  <profile isAReservationTicket="false" isDefault="false" name="AppSrv01"
  path="/QIBM/UserData/WebSphere/AppServer/V61/Base/profiles/AppSrv01"
  template="/QIBM/ProdData/WebSphere/AppServer/V61/Base/profileTemplates/default"
  />
</profiles>
```

Figure 4-38 profileregistry.xml file contents

Each application server profile has a separate entry in the profileregistry.xml file. Each entry consists of the <profile> tag and attributes that tell you various information about the profile, such as the name of the profile, profile path, template path, and so on.

## 4.2.8 Deleting an application server profile

In this section, we show two ways that you can delete an application server profile: using QShell script or IBM Web Administration for i5/OS.

### Deleting an application server profile using manageprofiles

Here we describe how to delete an application server profile. The method we describe uses the manageprofiles script. Deleting a profile does not delete the profile directory. If you plan to reuse the same name later, you must manually delete the directory.

Table 4-5 contains the parameter that is required to delete an application server profile.

Table 4-5 manageprofiles parameters used when deleting an application server profile

Parameter name	Sample value	Description
-profileName	WASSvr01	Specifies the name of the profile to be deleted

Complete the following steps to delete an application server profile:

1. Start a 5250 emulator session and sign on.
2. Start a QShell session with the STRQSH command.
3. Change to the core binary product files location:

```
cd /QIBM/ProdData/WebSphere/AppServer/V61/Base/bin
```

**Note:** The default location of the core binary product files can change depending on the application server edition, type, or custom settings. In our examples, we assume that WebSphere Application Server V6.1 Base is installed in the default location.

4. Stop the application server if it is running (see 4.2.4, “Stopping an application server” on page 113).
5. Run the manageprofiles script with the parameters we specified in Table 4-5 on page 127.

```
manageprofiles -delete -profileName WASSvr01
```

Example 4-6 shows the messages that the manageprofiles script sends during the deletion of an application server profile.

*Example 4-6 Deleting of an application server profile*

---

```
> manageprofiles -delete -profileName WASSvr01
INSTCONFSUCCESS: Success: The profile no longer exists.
$
===>
```

---

The command finished successfully and the profile is no longer available.

6. Consider if you need to remove the profile’s directory.

## Deleting an application server profile using IBM Web Administration for i5/OS

In this section, we describe how to delete an application server profile using IBM Web Administration for i5/OS. We suggest this method for users who do not feel comfortable with using Qshell commands.

Complete the following steps to delete an application server profile using IBM Web Administration for i5/OS:

1. Open and login to IBM Web Administration for i5/OS as we described in 4.2.1, “Starting IBM Web Administration for i5/OS” on page 89
2. Click the **IBM Web Administration for i5/OS** link. A window similar to Figure 4-39 on page 129 is displayed.

3. IBM Web Administration for i5/OS contains a set of tabs that allow you to work with different subsets of information. Click the **Manage** tab, as shown in Figure 4-39, to manage servers running on your system.

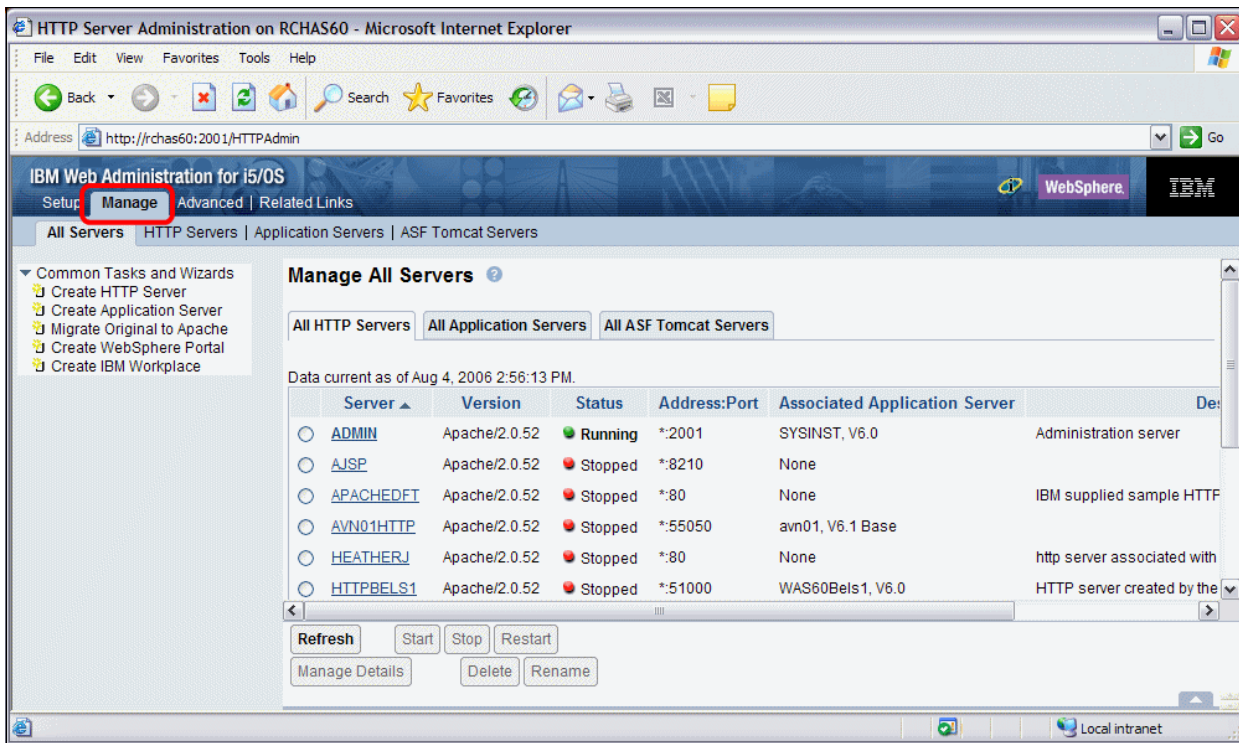

Figure 4-39 IBM Web Administration for i5/OS - Manage All Servers tab

4. IBM Web Administration for i5/OS allows you to work with HTTP servers, application servers, and ASF Tomcat servers. Click the **All Application Servers** tab as shown in Figure 4-40 on page 130.

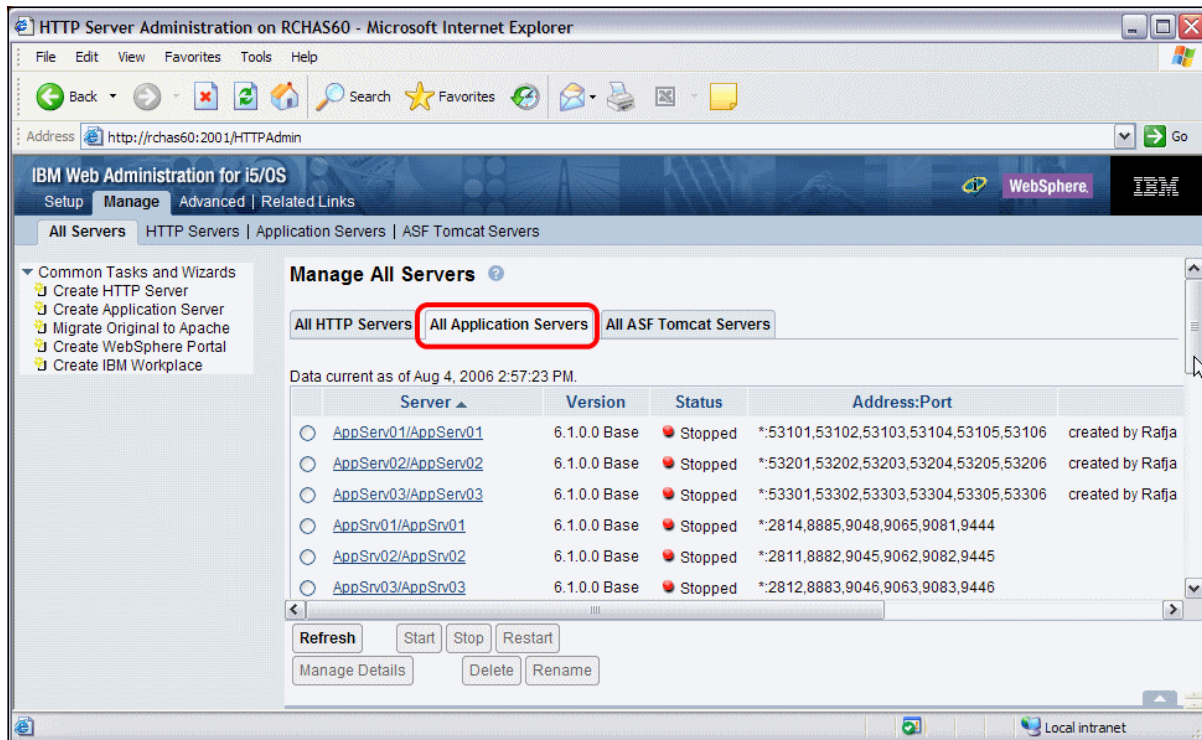

Figure 4-40 IBM Web Administration for i5/OS - List of the application servers defined

5. The right side of the window shows a list of all of the application servers profiles that are defined. Select the profile that you want to work with. Click **Stop** if the selected profile is still running.

6. When the profile is in the *Stopped* status, click **Delete** as shown in Figure 4-41.

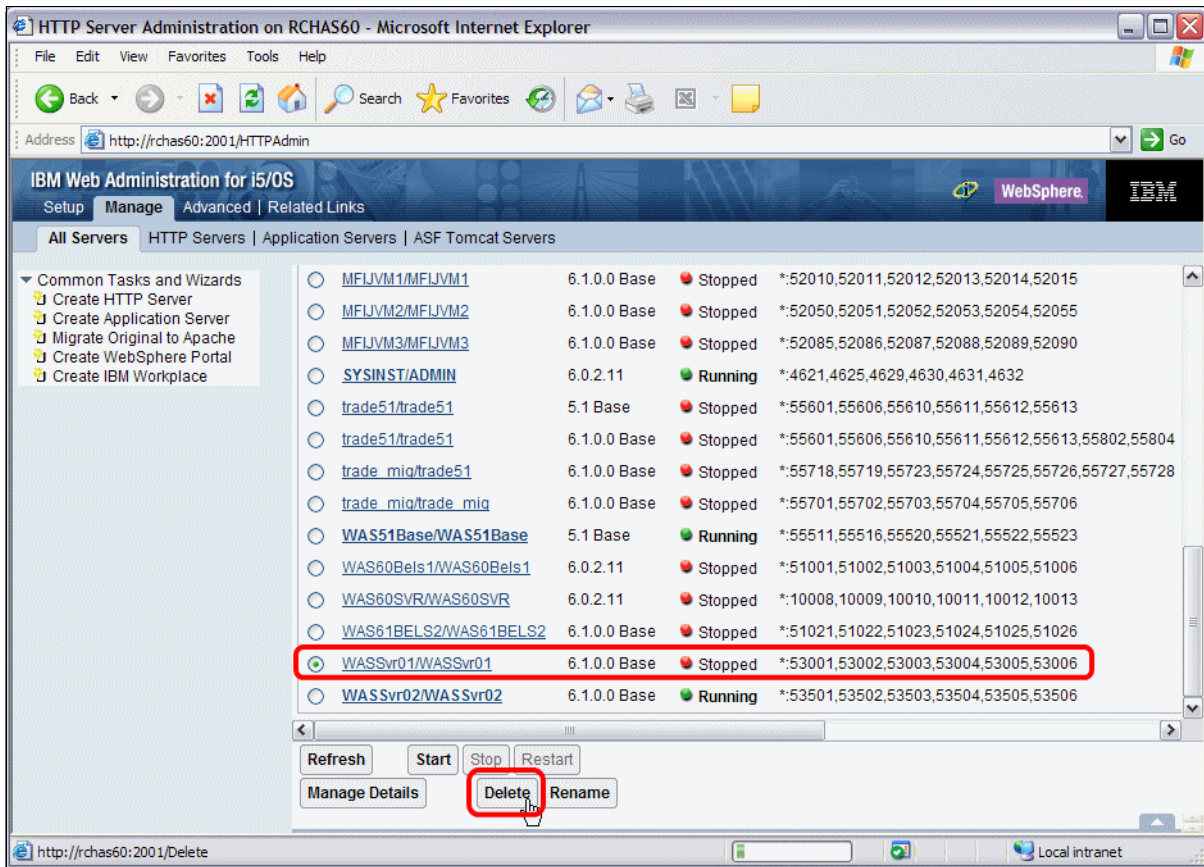

Figure 4-41 IBM Web Administration for i5/OS - Deleting the application server profile

7. Before you delete the application server profile, the wizard gives you the option of deleting just the application server profile or also the HTTP server instance that is associated with the application server profile. Select whether you want to also delete the HTTP server instance, as shown in Figure 4-42 on page 132, and click **Next**.

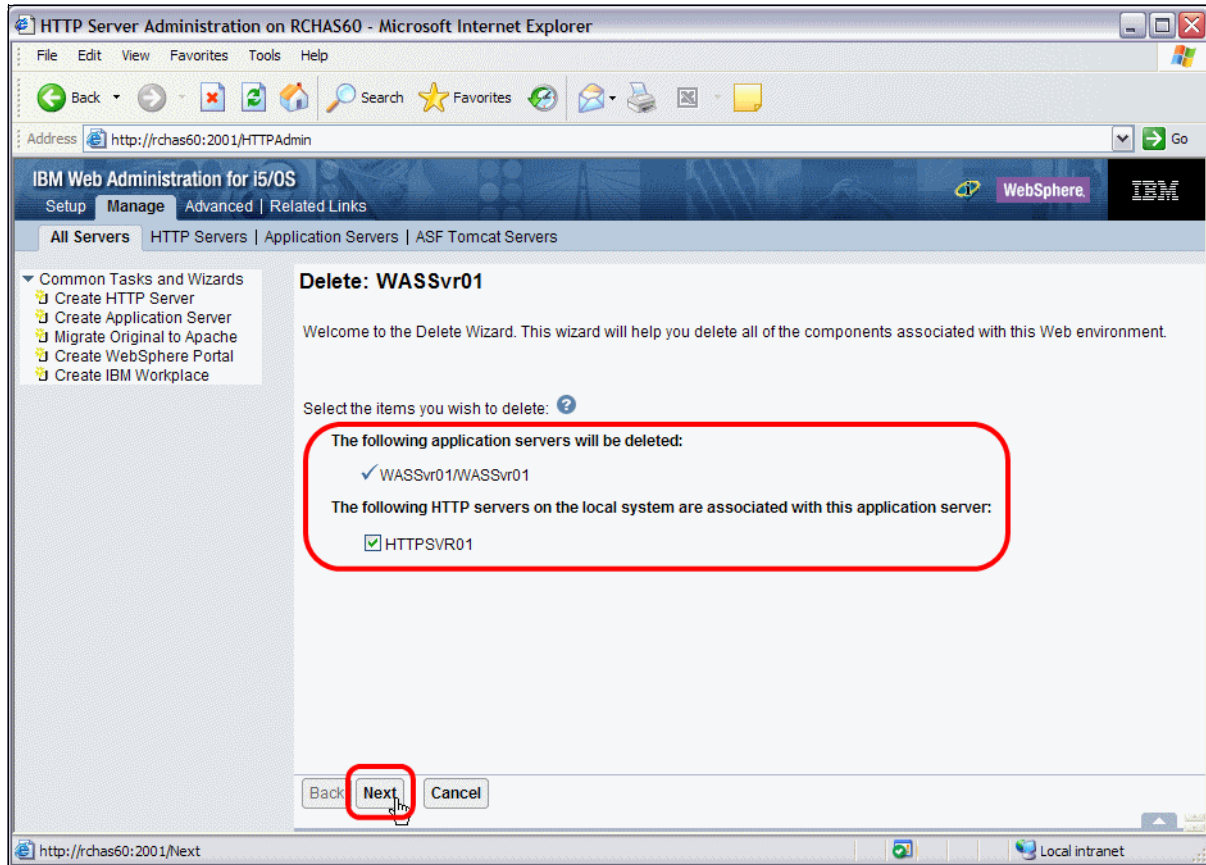

Figure 4-42 IBM Web Administration for i5/OS - Selecting whether to also delete the HTTP server instance

8. In Figure 4-43 on page 133, the wizard asks you to confirm the selection. Confirm you that you selected the correct profile(s), and click **Delete**.

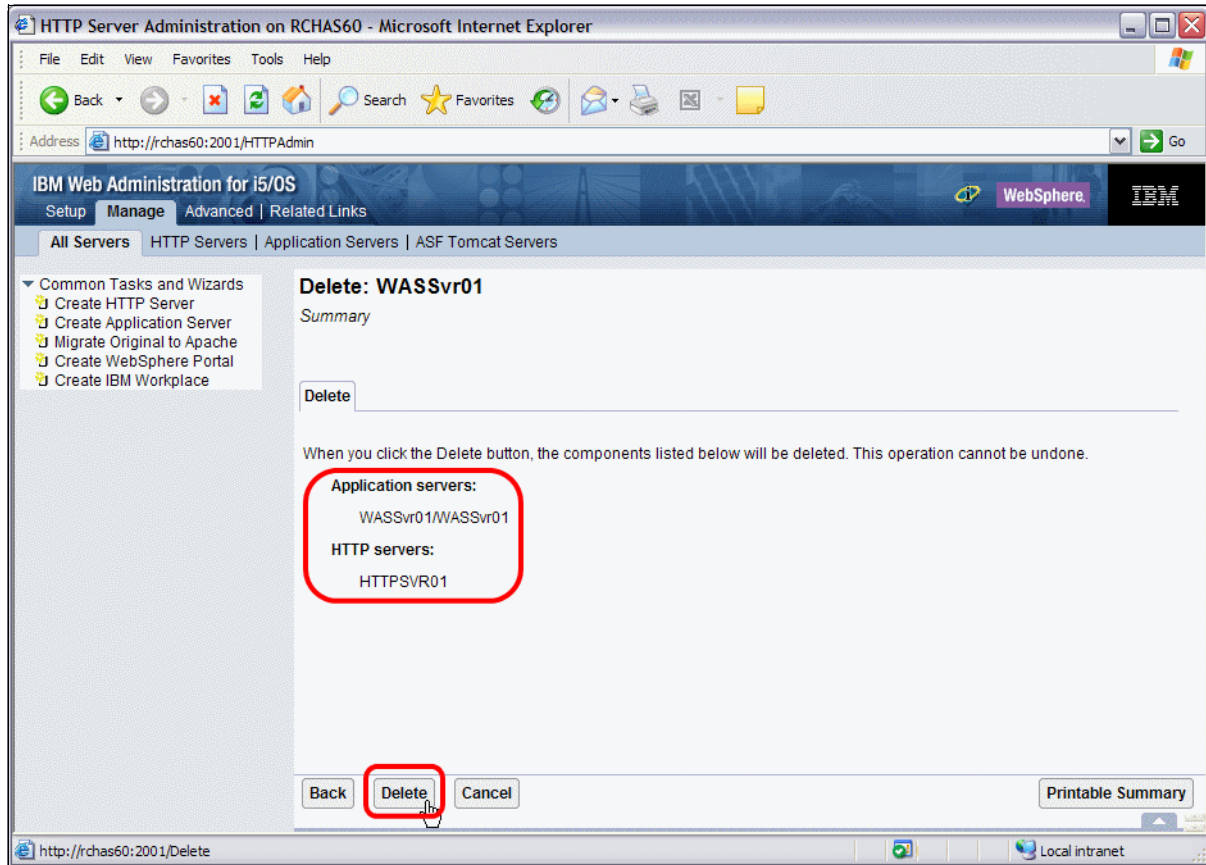

Figure 4-43 IBM Web Administration for i5/OS - Confirming application server profile to delete

9. The amount of time that is required to delete the application server profile depends on many factors, such as current server load, available memory in the pool, and so on. The current status of the process is visible in the application server profile entry as shown in Figure 4-44 on page 134. You can click **Refresh** to see the latest status.

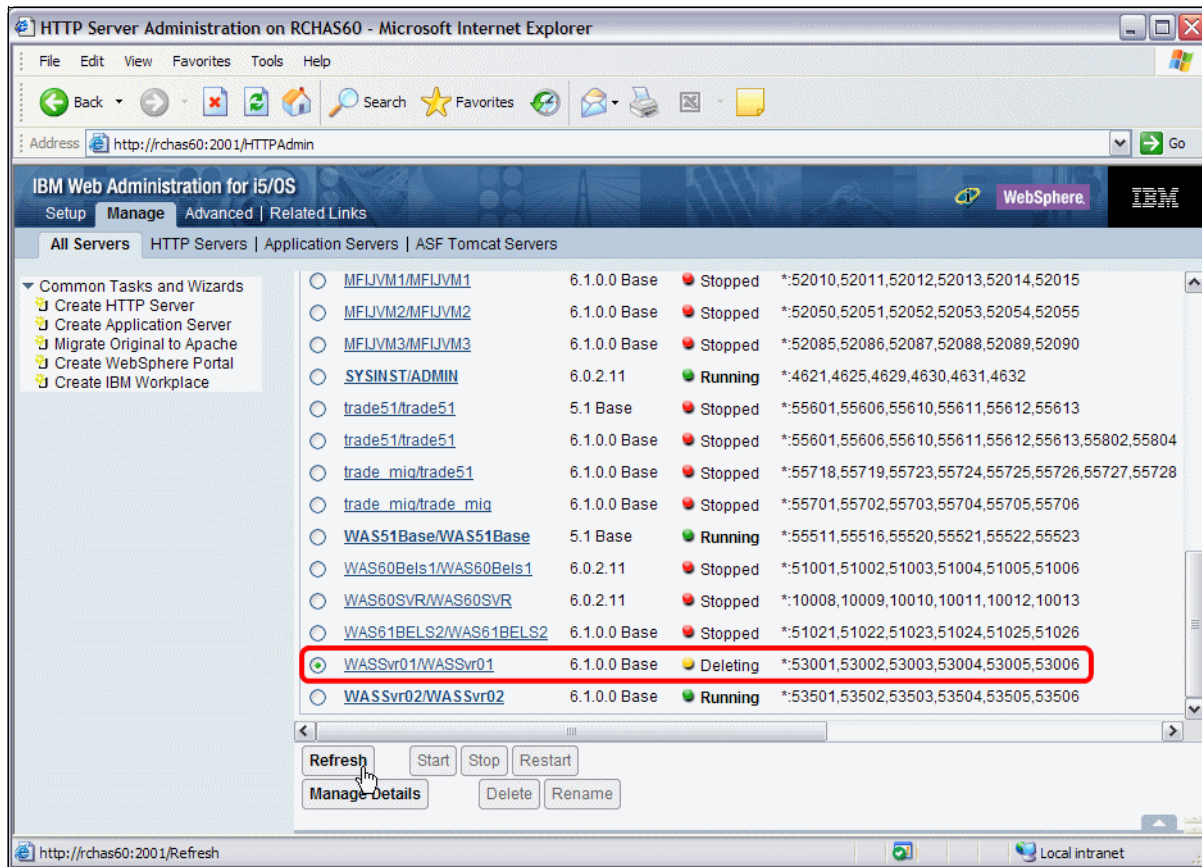

Figure 4-44 IBM Web Administration for i5/OS - Deleting application server profile status

After the application server profile is deleted, it is no longer visible in the list.

## 4.2.9 Creating an application server cell

*Cells* are logical groupings of one or more *nodes* in a WebSphere Application Server distributed network. A node is a grouping of application servers that are running on one machine or partition. You can have multiple Application Server Nodes on a single machine depending on the configuration, as shown in Figure 4-45 on page 135.

A cell is a configuration concept, a way for administrators to logically associate nodes with one another. Administrators define the nodes that make up a cell, according to the specific criteria that makes sense in their organizational environments. A cell consists of a deployment manager profile and one or more WebSphere profiles.

Figure 4-45 shows multiple Application Server Nodes on a single machine.

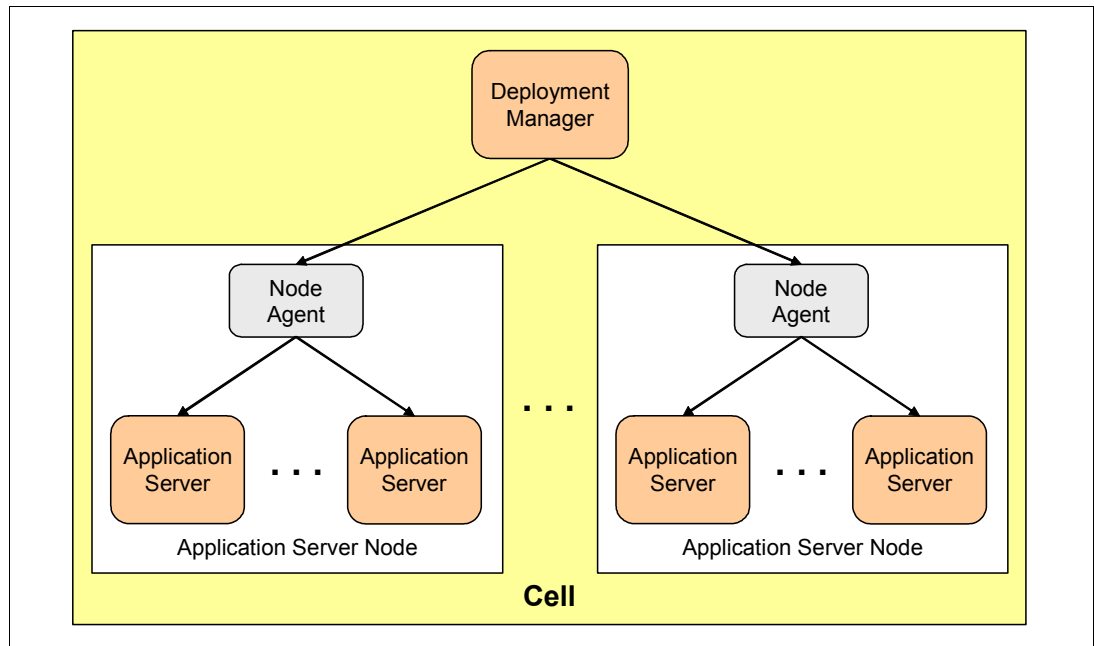

Figure 4-45 Overview of a Cell

Deployment managers are administrative agents that provide a centralized management view for all nodes in a cell. They also manage clusters and workload balancing of application servers across one or more nodes. A deployment manager hosts the administrative console for a cell. The Deployment Manager manages one or more nodes in a distributed topology (cell). Each cell contains one deployment manager that communicates with the *Node Agent* for configuration and operational management of the application servers within that node. The Node Agent is purely an administrative agent and is not involved in application serving functions. A Node Agent is created under the covers when you add (*federate*) a stand-alone server to a Cell.

**Important:** For the creation of a cell, you must have WebSphere Application Server Network Deployment V6.1 installed. You can create one or more deployment manager profiles, one or more cell profiles, one or more WebSphere profiles, as well as any HTTP server profiles that are required. WebSphere Application Server Base and Express Editions cannot create the deployment manager or cell profiles that are required to create a cell.

### Creating an application server cell using manageprofiles

In this section, we describe the process of creating an application server cell using the Qshell environment. We do not provide guidance on how to choose a topology for a cell because there are many possible configurations that are suited to different purposes and environments. Refer to Chapter 5 of the IBM Redbooks publication *WebSphere Application Server V6.1: Planning and Design*, SG24-7305 for information about choosing a topology.

### Configuring the deployment manager

When you install WebSphere Application Server Network Deployment V6.1, you have the option of creating a Cell profile, which consists of a deployment manager profile and application server profile on a single machine or partition. However it is also possible to

create the deployment manager after installation or to create additional deployment manager profiles by using the manageprofiles script.

Table 4-6 lists the parameters that we used to create a WebSphere Application Server deployment manager profile.

Table 4-6 *manageprofiles* parameters used to create the Deployment Manager

Parameter name	Sample value	Description
-profileName	MyDmgr	Specifies the name of the profile
-templatePath	dmgr	Specifies the directory path to the template files
-startingPort	20051	Specifies the starting port number for the profile

Complete the following steps to create the Deployment Manager:

1. Start a 5250 emulator session and sign on.
2. On the i5/OS command line, enter the Start Qshell (STRQSH) command.
3. Change to the core binary product files location:

```
cd /QIBM/ProdData/WebSphere/AppServer/V61/ND/bin
```

**Note:** The default location of the core binary product files can change depending on the application server edition, type, or custom settings. In our examples, we assume that WebSphere Application Server V6.1 ND is installed in the default location.

4. Run the manageprofiles script with the parameters that we specified in Table 4-6.

```
manageprofiles -create -profileName MyDmgr -templatePath dmgr -startingPort 20051
```

Example 4-7 shows messages that the manageprofiles script sends while it creates the Deployment Manager profile.

Example 4-7 *manageprofiles* output while creating a deployment manager profile

---

```
>manageprofiles -create -profileName MyDmgr -templatePath dmgr -startingPort 20051
INSTCONFSUCCESS: Success: Profile MyDmgr now exists. Please consult
/QIBM/UserData/WebSphere/AppServer/V61/ND/profiles/MyDmgr/logs/AboutThisProfile.txt for
more information about this profile.
$
===>
```

---

The command finished successfully and the deployment manager profile was created.

The next step in setting up your WebSphere Application Server cell is to start the Deployment Manager.

5. To start the Deployment Manager profile, type the **startManager -profileName MyDmgr** command.

After the Deployment Manager is started, messages are displayed that are similar to Example 4-8 in the Qshell session.

Example 4-8 *Starting deployment manager profile*

---

```
> startManager -profileName MyDmgr
CPC1221: Job 113212/QEJBSVR/MYDMGR submitted to job queue QWASJOBQ in
library QWAS61.
```

CWNATV001: Application server MyDmgr in profile MyDmgr has started and is ready to accept connections on admin port 20051.

\$

As a result of using the **startManger** command, one job in the QWAS61 subsystem is started. The name of the job is the same as the name of the Deployment Manager profile (MyDmgr).

**Important:** The admin port for the WebSphere Application Server profile is shown in the output for the **startManger** command. This port is required when you open the WebSphere Administrative Console. As shown in Example 4-8 on page 136, the admin port is 20051 in this case.

6. Start the deployment manager console. See “Accessing the WebSphere Administrative Console directly” on page 121 for details about how to start the console.

### **Creating WebSphere profiles**

To better demonstrate our WebSphere Application Server cell we create two WebSphere profiles that are federated into the cell. The way the WebSphere profiles are created is similar to the methods we previously described in 4.2.2, “Creating an application server profile” on page 92.

Table 4-7 and Table 4-8 list parameters that we use to create each application server profile.

*Table 4-7 Parameters used to create first application server profile*

Parameter name	Sample value	Description
-profileName	MyAppSvr01	Application servers profile name
-startingPort	20101	Starting port number for the profile
-templatePath	default	Directory path to the template files

*Table 4-8 Parameters used to create second application server profile*

Parameter name	Sample value	Description
-profileName	MyAppSvr02	Application servers profile name
-startingPort	20201	Starting port number for the profile
-templatePath	default	Directory path to the template files

Complete the following steps to create the WebSphere profiles for the cell:

**Note:** You can create these and other profiles on the remote (in relation to the deployment manager) machine or partition. In our example we create both profiles on the same machine where we run the deployment manager.

1. Start a 5250 emulator session and sign on.
2. Start a QShell session with the STRQSH command.
3. Change to the core binary product files location:  
`cd /QIBM/ProdData/WebSphere/AppServer/V61/ND/bin`

**Note:** The default location of the core binary product files can change depending on the application server edition, type, or custom settings. In our examples, we assume that WebSphere Application Server V6.1 ND is installed in the default location.

4. Run the manageprofiles script with the parameters that we listed in Table 4-7 on page 137 in order to create the first application server profile.

```
manageProfiles -create -profileName MyAppSvr01 -templatePath default
-startingPort 20101
```

5. Run the manageprofiles script with the parameters listed in Table 4-8 on page 137 in order to create the second application server profile.

```
manageProfiles -create -profileName MyAppSvr02 -templatePath default
-startingPort 20201
```

Example 4-9 shows the manageprofiles script output messages after it created both of the WebSphere profiles.

*Example 4-9 Creating application servers profiles*

---

```
>manageProfiles -create -profileName MyAppSvr01 -templatePath default -startingPort 20101
Attaching Java program to
/QIBM/ProdData/WebSphere/AppServer/V61/ND/profileTemplates/managed/lib/managedResource.jar.
INSTCONFSUCCESS: Success: Profile MyAppSvr01 now exists. Please consult
/QIBM/UserData/WebSphere/AppServer/V61/ND/profiles/MyAppS
vr01/logs/AboutThisProfile.txt for more information about this profile.
$
>manageProfiles -create -profileName MyAppSvr02 -templatePath default -startingPort 20201
INSTCONFSUCCESS: Success: Profile MyAppSvr02 now exists. Please consult
/QIBM/UserData/WebSphere/AppServer/V61/ND/profiles/MyAppS
vr02/logs/AboutThisProfile.txt for more information about this profile.
$
===>
```

---

The command finished successfully and two new WebSphere profiles were created.

***Federating WebSphere profiles into the cell***

Federating (adding) application servers into a cell allows you to create a WebSphere cell with all benefits of the WebSphere Application Server Network Deployment. After federating into a cell, the servers are centrally administered from the Deployment Manager. Before adding servers (nodes) to a cell, the Deployment Manager's host name and SOAP port must be known.

Before we proceed with federation, we check the Deployment Manager SOAP connector port that the addNode script uses during federation. Complete the following steps to federate MyAppSvr01 and MyAppSvr02 into the cell:

1. Start a 5250 emulation session to the machine where you run the Deployment Manager.
2. Start a QShell session with the STRQSH command.
3. Change to the core binary product files location:

```
cd /QIBM/ProdData/WebSphere/AppServer/V61/ND/bin
```

**Note:** The default location of the core binary product files can change depending on the application server edition, type, or custom settings. In our examples, we assume that WebSphere Application Server V6.1 ND is installed in the default location.

4. Run the `dspwasinst` script with the Deployment Manager profile name as a parameter.

```
dspwasinst -profileName MyDmgr
```

Example 4-10 shows an extract of the `dspwasinst` output messages. The command in fact displays more messages, however in this example we are interested only in the SOAP port displayed in the output.

*Example 4-10 Creating application servers profiles*

---

```
> dspwasinst -profileName MyDmgr
Display WAS instance:
Instance name: MyDmgr
Profile path: /QIBM/UserData/WebSphere/AppServer/V61/ND/profiles/MyDmgr
Template path: /QIBM/ProdData/WebSphere/AppServer/V61/ND/profileTemplates/dmgr
...
...
...
Additional ports:
    20059  CELL_DISCOVERY_ADDRESS port
    20053  BOOTSTRAP_ADDRESS port
    20054  SOAP_CONNECTOR_ADDRESS port
    20058  ORB_LISTENER_ADDRESS port
    20055  SAS_SSL_SERVERAUTH_LISTENER_ADDRESS port
    20057  CSIV2_SSL_MUTUALAUTH_LISTENER_ADDRESS port
    20056  CSIV2_SSL_SERVERAUTH_LISTENER_ADDRESS port
    20051  WC_adminhost port
    20060  DCS_UNICAST_ADDRESS port
    20052  WC_adminhost_secure port

$ ==>
```

---

Look at the `SOAP_CONNECTOR_ADDRESS` port. In this example, the port value is 20054.

5. Run the `addNode` script twice to federate both WebSphere profiles to the cell.

```
addNode localhost 20054 -profileName MyAppSvr1
addNode localhost 20054 -profileName MyAppSvr2
```

If your application servers are on a remote machine to the `dspwasinst` machine, run the `addNode` command on the machine where you run the application servers.

**Attention:** The first two parameters of the `addNode` script specify the host name and the port number of the `dspwasinst` profile. In Example 4-11, both application servers and the Deployment Manager reside on the same partition, which is why we were able to specify `localhost` as the host name of the Deployment Manager; otherwise, you would have to specify the host name of the Deployment Manager machine.

After both commands complete, the `MyAppSvr01` node and `MyAppSvr02` node are said to be “federated into the cell”. Example 4-11 shows an extract of the messages logged by the `addNode` command.

*Example 4-11 AddNode command output messages*

---

```
Starting tool with the MyAppSvr01 profile
...
ADMU0001I: Begin federation of node RCHAS60_MyAppSvr01 with Deployment Manager
           at localhost:20054.
ADMU0009I: Successfully connected to Deployment Manager Server: localhost:20054
...
```

```
ADMU2010I: Stopping all server processes for node RCHAS60_MyAppSvr01
...
ADMU0300I: The node RCHAS60_MyAppSvr01 was successfully added to the
MyDmgrNetwork cell.
...
ADMU0306I: Note:
ADMU0304I: Because -includeapps was not specified, applications installed on
the standalone node were not installed on the new cell.
ADMU0307I: You might want to:
ADMU0305I: Install applications onto the MyDmgrNetwork cell using wsadmin
$AdminApp or the Administrative Console.
ADMU9990I:
ADMU0003I: Node RCHAS60_MyAppSvr01 has been successfully federated.
$
```

---

Both application servers' profiles were successfully federated into the cell. The **addNode** command creates and starts the *Node Agent* on the machine. The Node Agent is an essential service that allows for communication between the Deployment Manager and each application server in the cell.

### ***Starting application servers from within the cell***

By default both WebSphere profiles that were federated into the cell are stopped. The process of starting a federated application server profile is different from starting a standalone one. To start federated WebSphere profiles, instead of the startServer script, we use the Deployment Manager administrative console.

Perform the following steps to start the federated WebSphere profiles:

1. Open the Deployment Manager Administrative Console.

**Tip:** See 4.2.6, "Accessing the WebSphere Administrative Console" on page 121 to learn how to open the Deployment Manager Administrative Console.

2. Click **System administration** → **Cell** in the navigation tree on the left of the console, as shown in Figure 4-46 on page 141. The work area, which occupies most of the console, shows the cell view.
3. Click **Local Topology** to retrieve the architecture of the cell. Click the plus (+) icon to see all of the components of your cell.

There are three nodes with the names similar to MyDmgrManager, RCHAS60\_MyAppSvr01 and RCHAS60\_MyAppSvr02. The last two nodes relate to the WebSphere profiles that serve user requests, which we created in the previous section. Each of these profiles contains an application server process and Node Agent process.

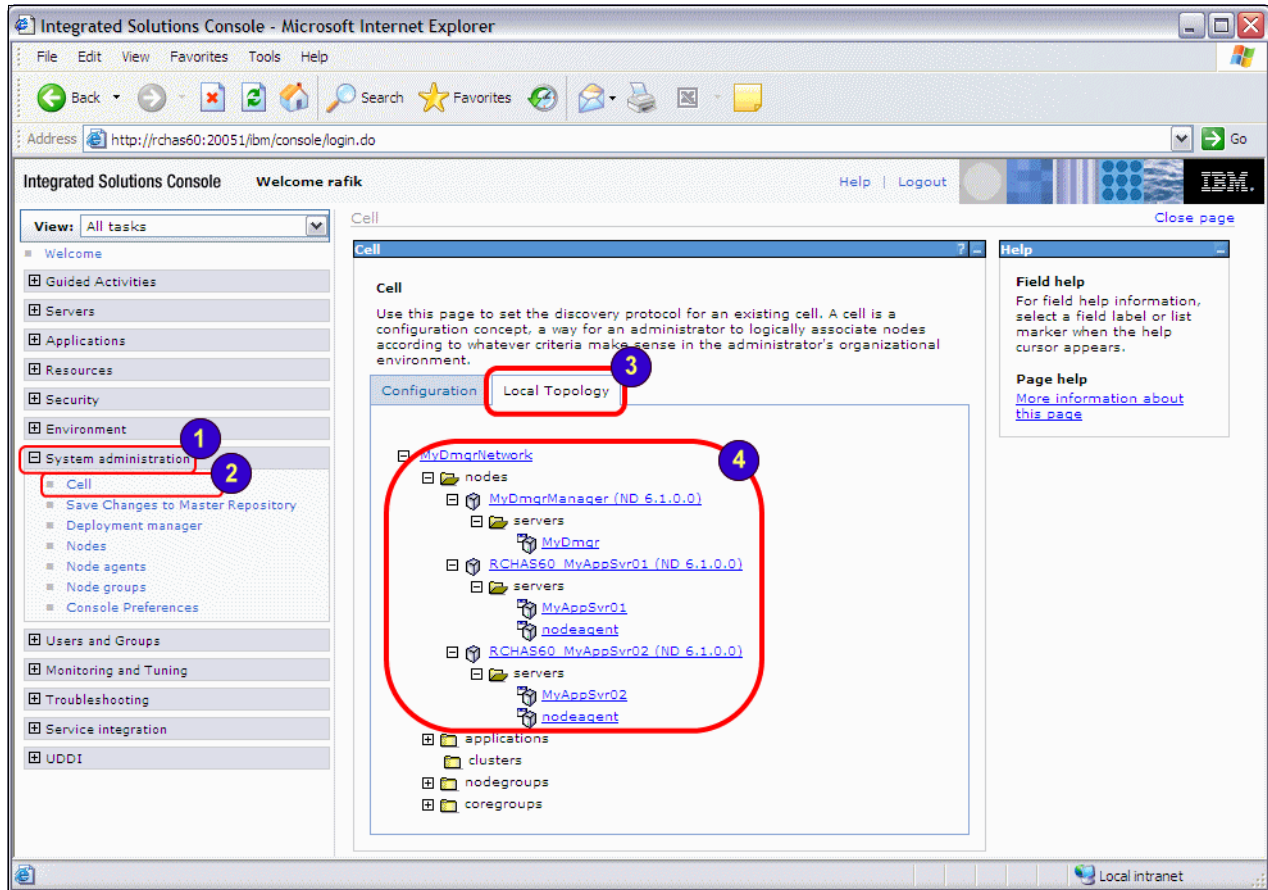

Figure 4-46 WebSphere Administrative Console - Welcome page

4. To start both WebSphere profiles, go to the navigation tree and click **Servers** → **Application servers** as shown in Figure 4-47 on page 142.
5. In the work area, you can see the Application servers view. Select both application servers, and click **Start**.

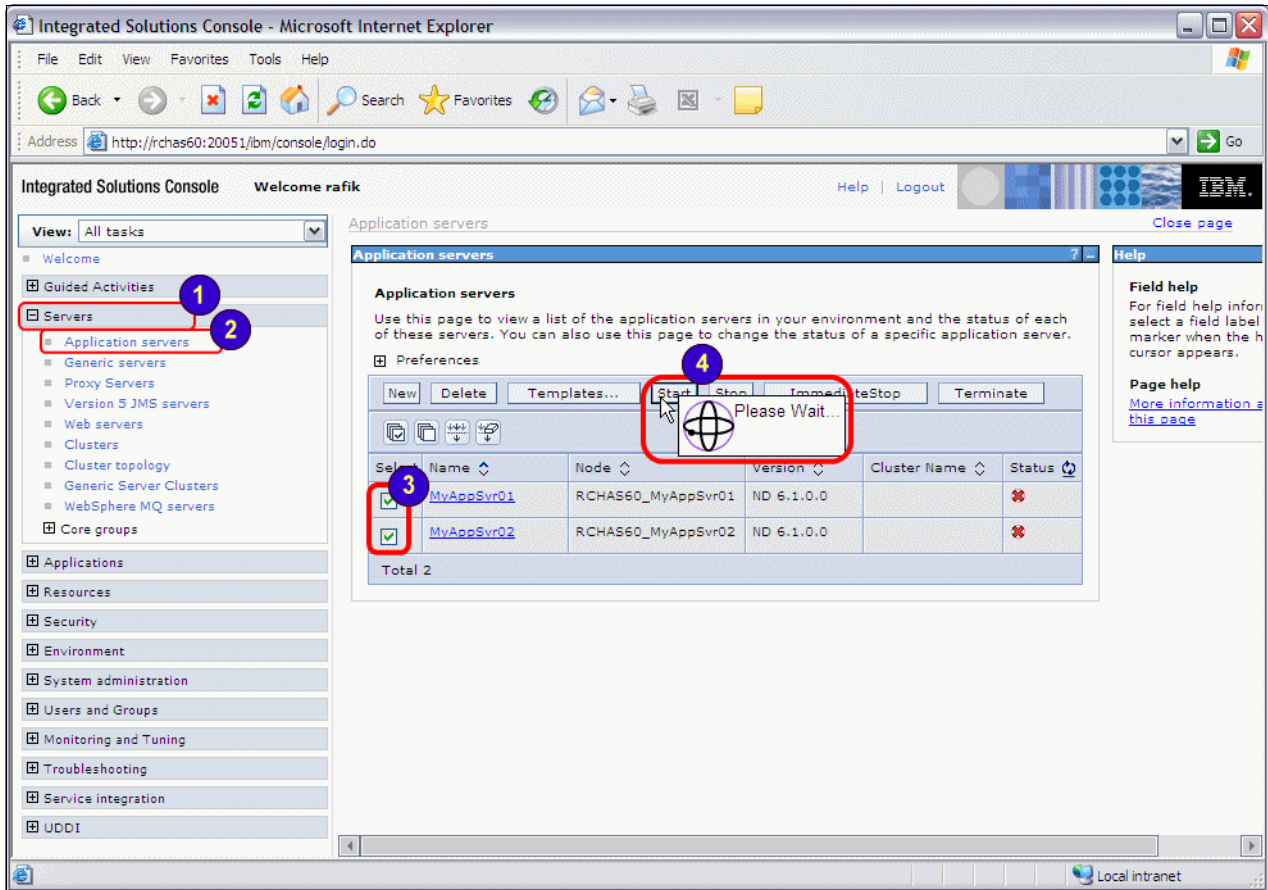

Figure 4-47 WebSphere Administrative Console - Starting application servers

After the application servers are started, a window similar to Figure 4-48 on page 143 is displayed.

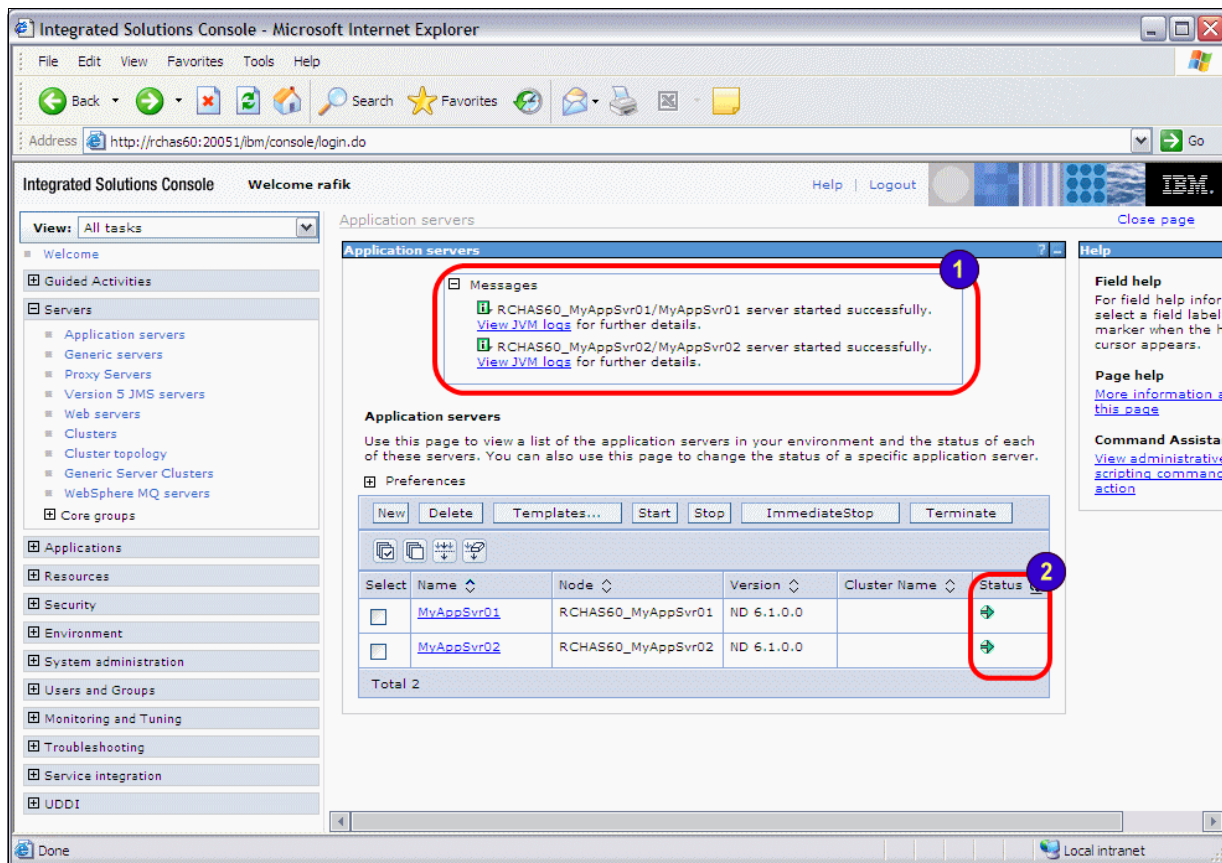

Figure 4-48 WebSphere Administrative Console - application servers started

We just went through the complete scenario of setting up a WebSphere Application Server cell environment. To make the WebSphere Application Server cell environment more functional, next we install applications into the cell. See Chapter 6, "Working with applications" on page 201 for more information.

To configure your cell for high availability and fail-over support, read the IBM Redbooks publication *WebSphere Application Server for iSeries V6: Building Advanced Configurations*, SG24-6637.

#### 4.2.10 Working with application server log files

WebSphere Application Server can write system messages to several general purpose logs, including JVM, process, and IBM service logs, which you can examine as part of problem determination.

The *JVM logs* are created by redirecting the System.out and System.err streams of the JVM to independent log files. In addition, applications and other code can write to these streams using the `print()` and `println()` methods defined by the streams. Typically, the System.out log monitors the health of the running application server. You can use the System.out log for problem determination, but we recommend that you use the *IBM Service log* and the advanced capabilities of the *Log and Trace Analyzer* instead. The System.err log contains exception stack trace information that is useful when performing problem analysis.

Because each application server is represented by one JVM, there is one set of JVM logs for each application server and all of its applications. It is located in:  
<profile\_root>/logs/server\_name

Assuming that our WebSphere Application Server V6.1 Base is installed in the default location and assuming that our profile and server name is AppServ01, the log files are under the following directory:

/QIBM/UserData/WebSphere/AppServer/V61/Base/profiles/AppServ01/logs/AppServ01/

During your day-to-day activities, most often you will monitor the health of the running applications. From that perspective, the System.out log is the first place to look.

### Examining System.out log file content

In this example, we demonstrate the simplest way to examine System.out log file content through the WebSphere administrative console. Perform the following steps to view the System.out log:

1. Open the WebSphere Administrative Console.

**Tip:** See 4.2.6, “Accessing the WebSphere Administrative Console” on page 121 to learn how to open the WebSphere administrative console.

2. Click **Troubleshooting** as shown in Figure 4-49.

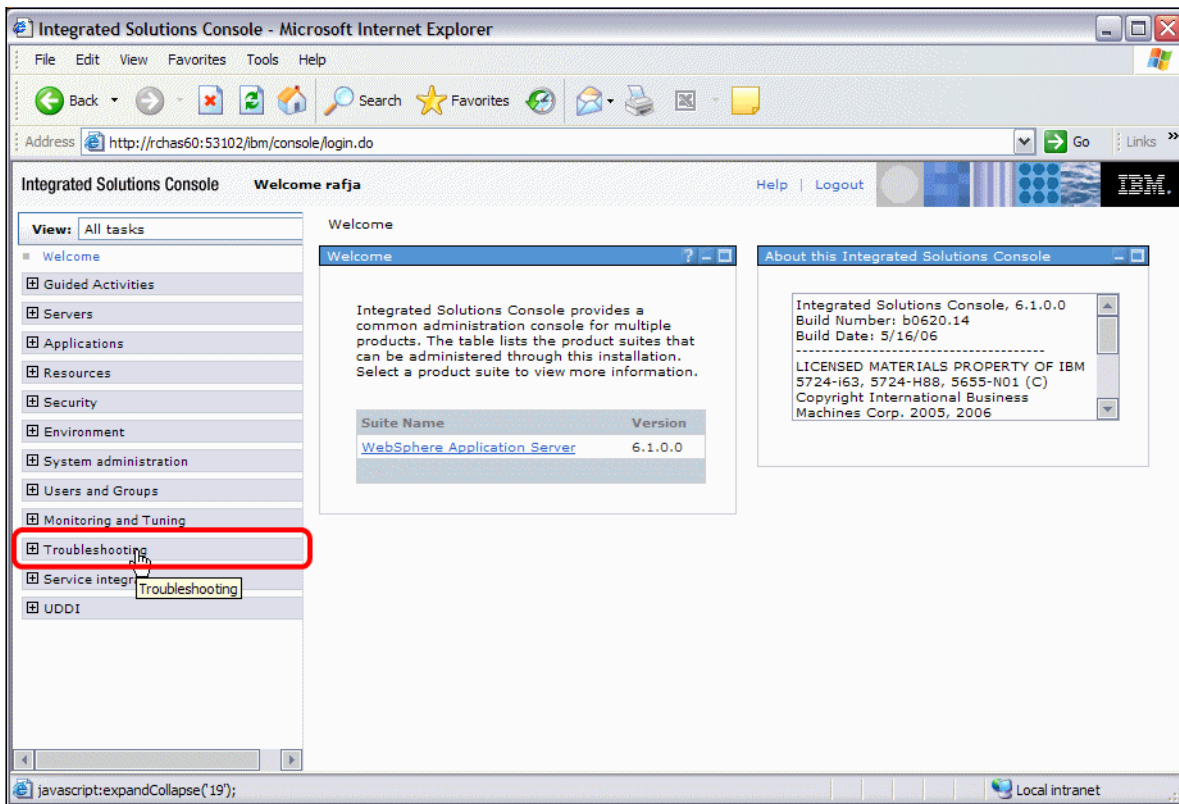

Figure 4-49 WebSphere Administrative Console - Welcome page

3. Click **Logs and Trace** as shown in Figure 4-50.

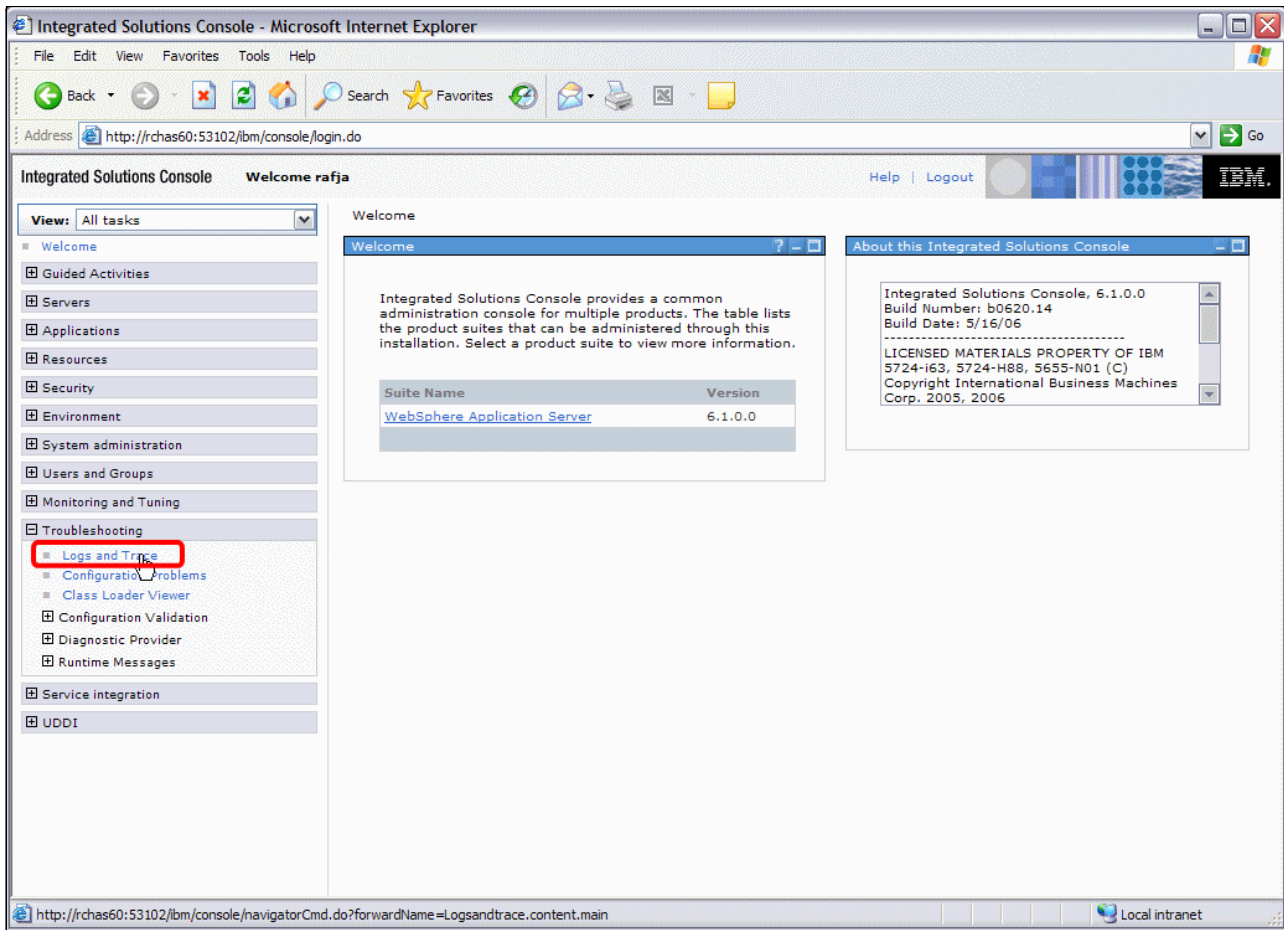

Figure 4-50 WebSphere Administrative Console - Log and Trace item

- Usually there is only one application server defined within the profile. Click it, as shown in Figure 4-51. If you defined more than one application server, select the one you want to work with.

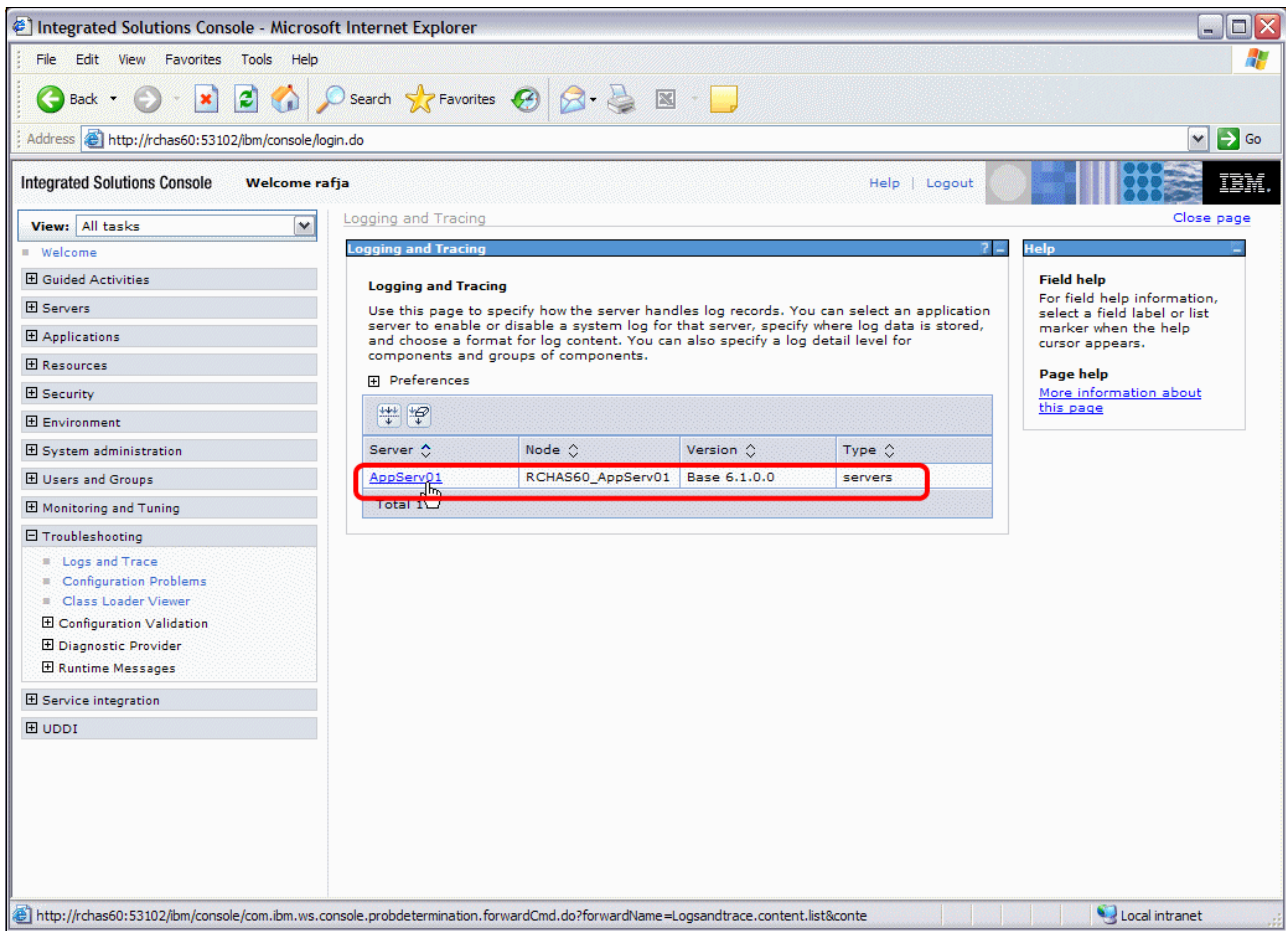

Figure 4-51 WebSphere Administrative Console - Application servers defined within the profile

5. To work with the standard outputs streams, click **JVM Logs** as shown in Figure 4-52.

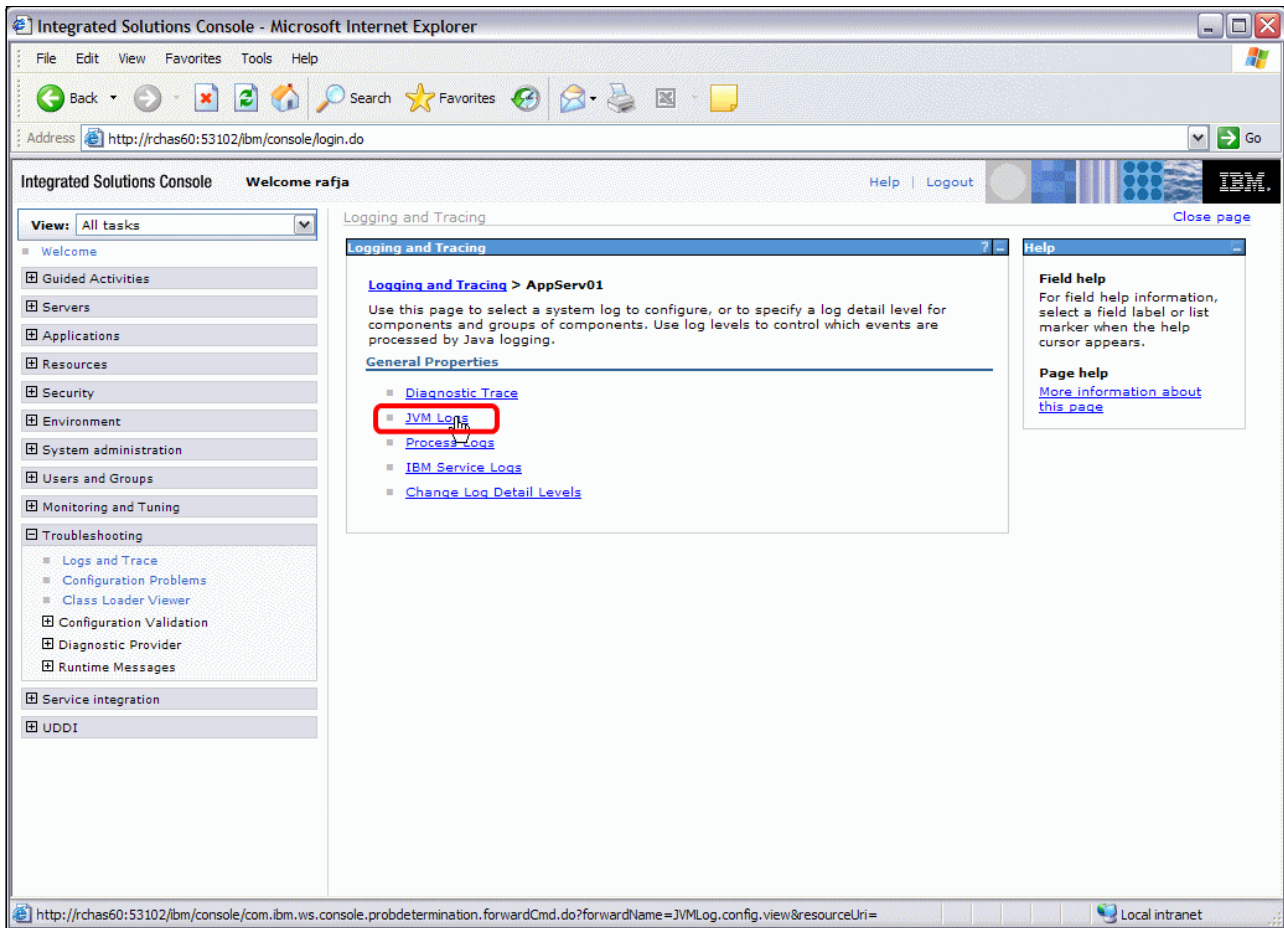

Figure 4-52 WebSphere Administrative Console - JVM Logs item

After clicking JVM Logs, the Configuration tab appears. This tab allows you to customize some of the log parameters.

6. Click the **Runtime** tab (Figure 4-53).

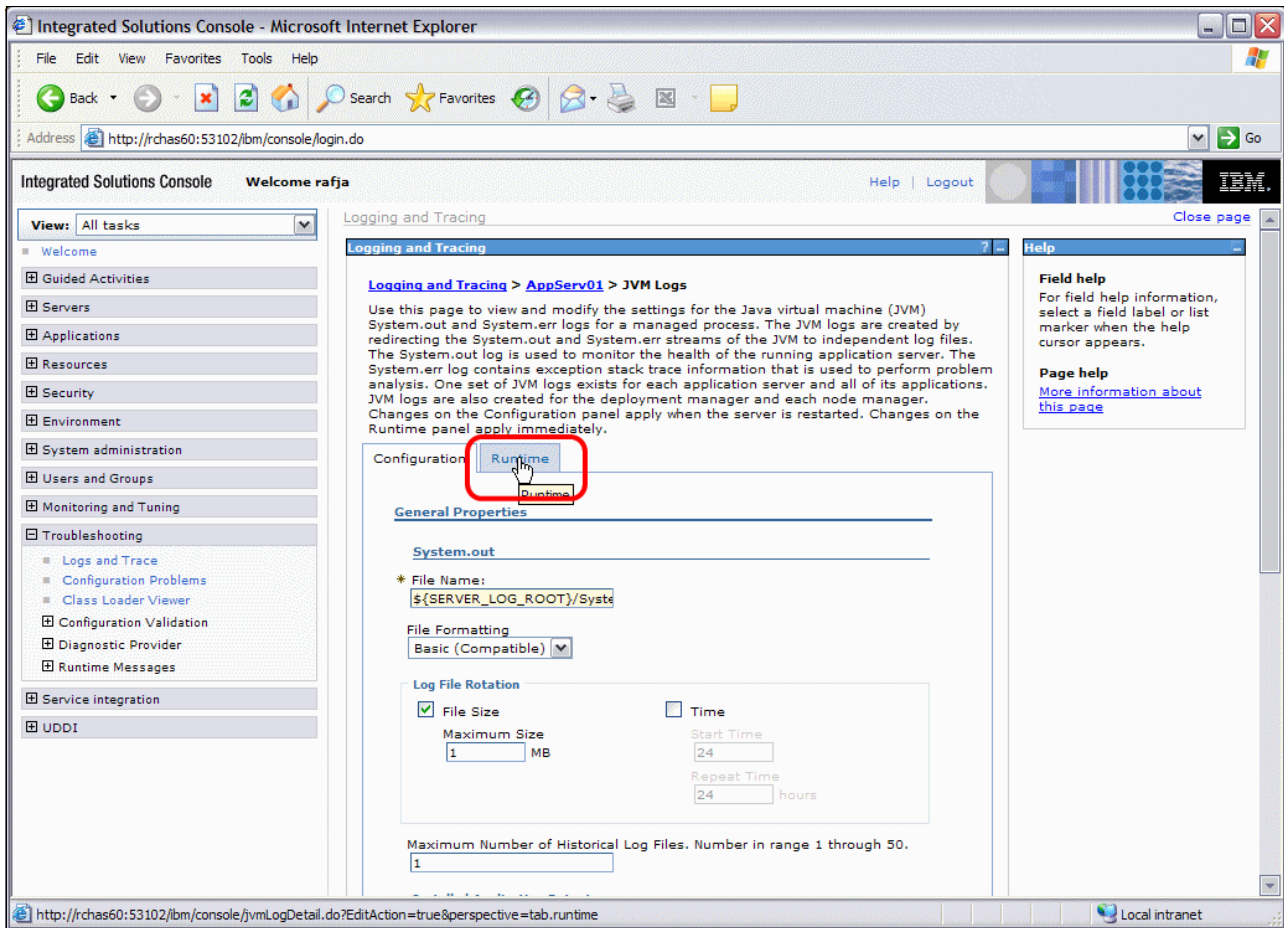

Figure 4-53 WebSphere Administrative Console - JVM logs configuration page

7. Click the **View** button, which is located next to the System.out stream as shown in Figure 4-54 on page 149.

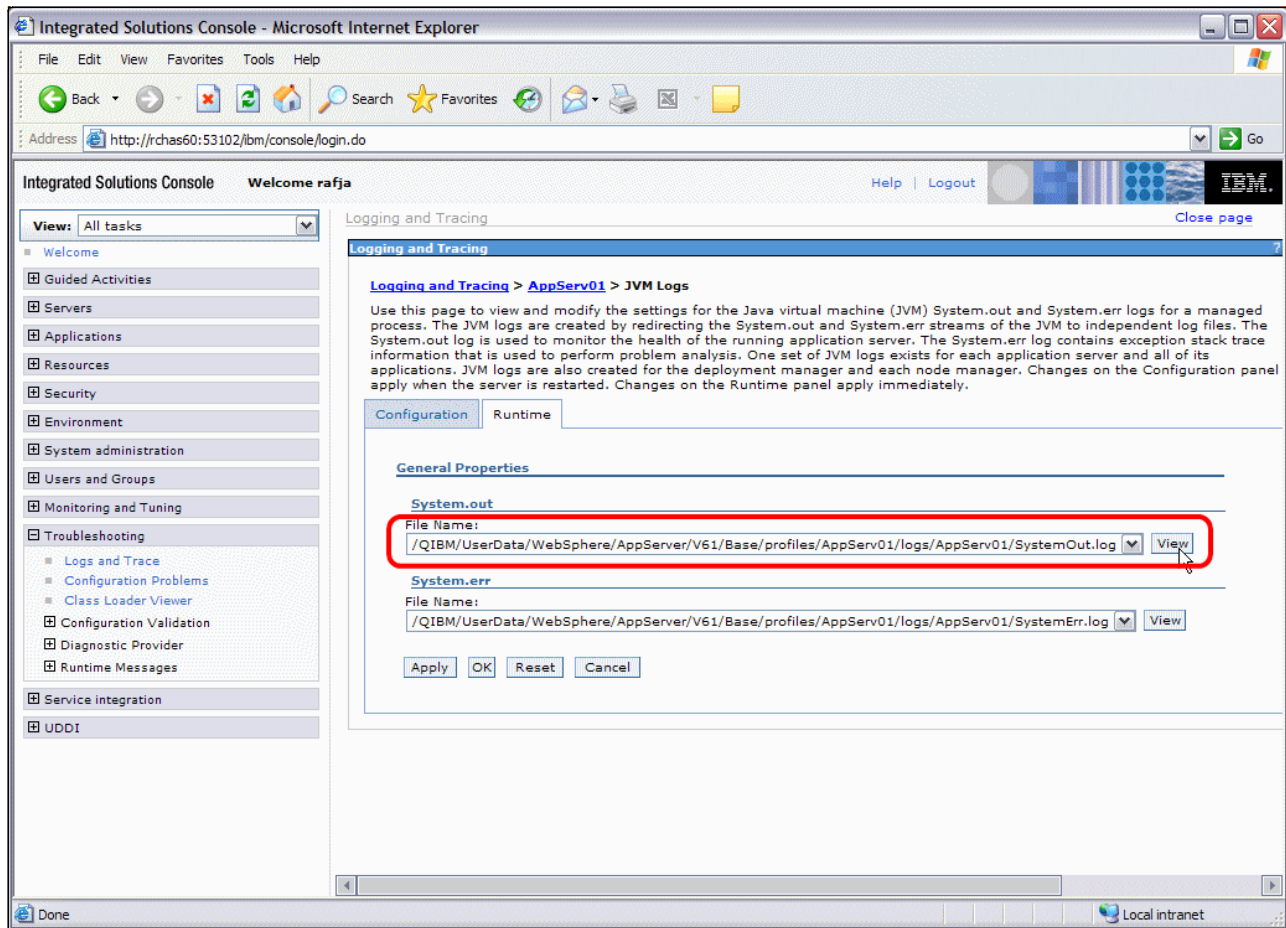

Figure 4-54 WebSphere Administrative Console - Standard output files

The log file for the standard output stream is displayed in the work area as shown in Figure 4-55 on page 150.

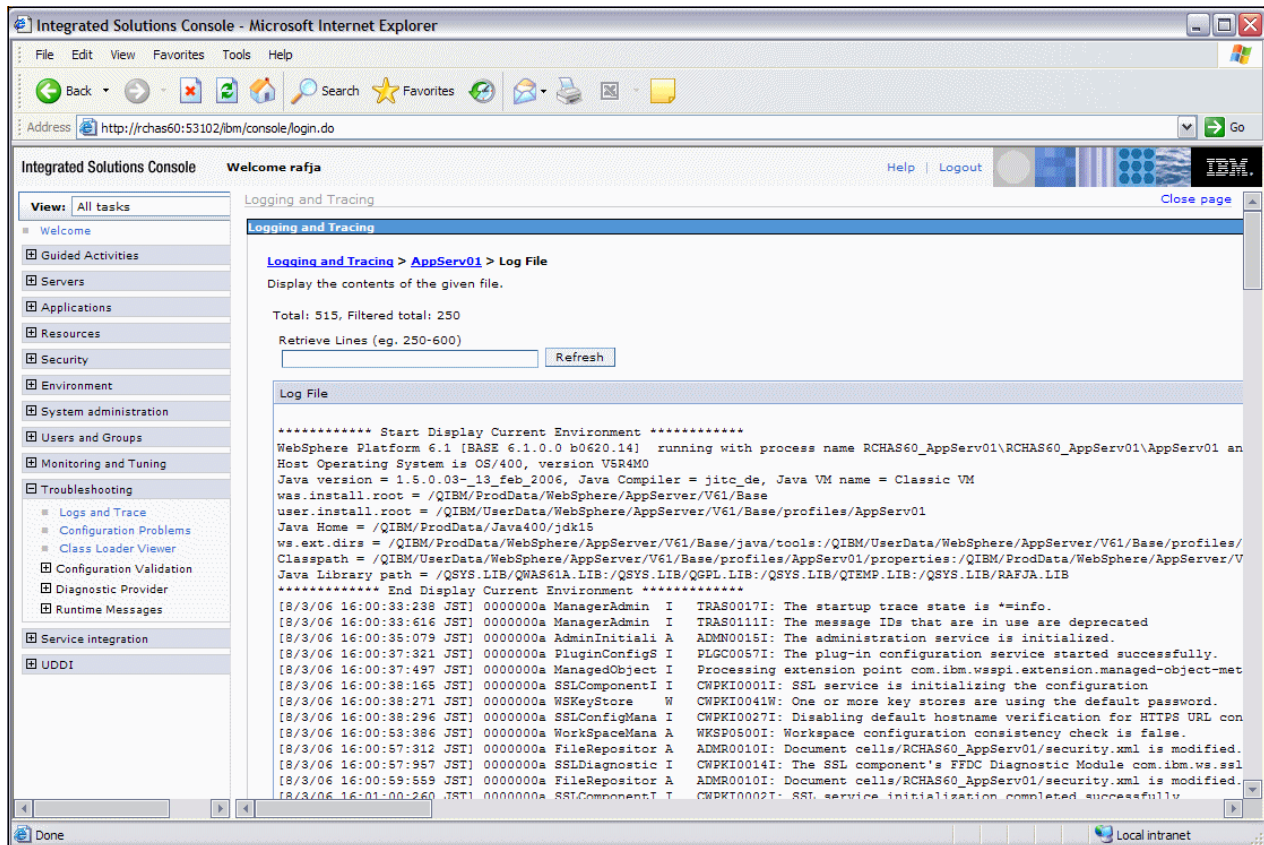

Figure 4-55 WebSphere Administrative Console - Standard output log file content

- By default the administrative console shows you only the beginning of the log file. Each time you want to retrieve any other range of log lines, you have to specify a range in the **Retrieve Lines** input field, and click **Refresh** as shown in Figure 4-56 on page 151. You also have to remember that the number of lines that you choose to retrieve impacts the time required to transfer them from the server to the browser.

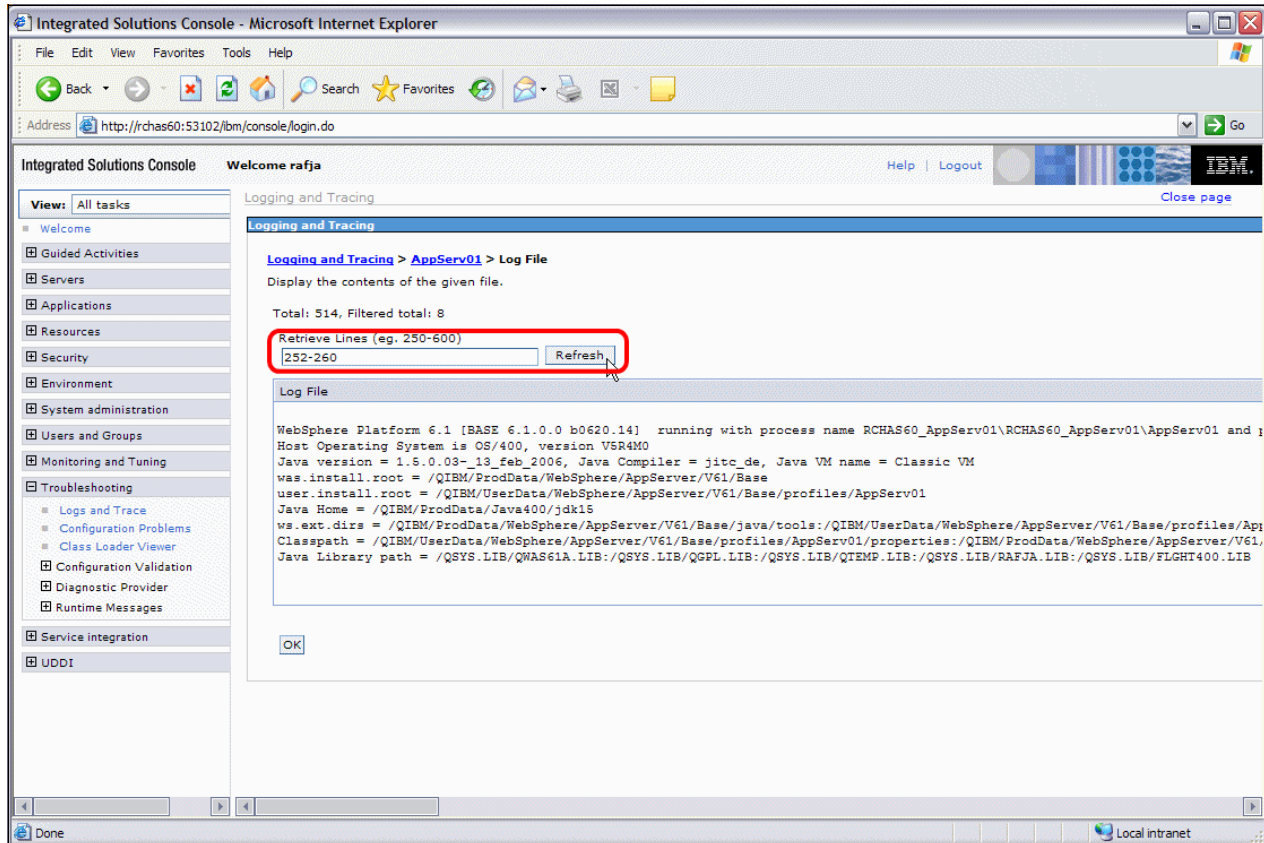

Figure 4-56 WebSphere Administrative Console - Specifying lines to retrieve

In this section, we showed you how to work with log files from the administrative console. There are other ways to work with logs (for example, at the i5/OS IFS level); however, remember that the administrative console is a central interface for the administrator to deal with application servers.

#### 4.2.11 Discovering TCP/IP ports assigned to the profile

To perform many administrative tasks, you must know the TCP/IP parameters for your application server. In this section, we provide instructions for identifying these parameters.

##### Using the Qshell environment to display TCP/IP ports

In this example, we describe how to determine which TCP/IP ports are assigned to the particular application server profile. There is a dedicated command that allows you to list various information about an application server profile. Included in the output is a section about TCP/IP ports.

Complete the following steps to display the TCP/IP ports assigned to an application server profile:

1. Start a 5250 emulator session and sign on.
2. Start a QShell session with the STRQSH command.
3. Change to the core binary product files location:
 

```
cd /QIBM/ProdData/WebSphere/AppServer/V61/Base/bin
```

**Note:** The default location of the core binary product files can change depending on the application server edition, type, or custom settings. In our examples, we assume that WebSphere Application Server V6.1 Base is installed in the default location.

4. Run the `dspwasinst` script with the your profile name as a parameter as shown below

```
dspwasinst -profileName AppServ01
```

Example 4-12 shows sample output from the `dspwasinst` command.

*Example 4-12 Partial dspwasinst output information*

---

```
> dspwasinst -profileName AppServ01
  Display WAS instance:
  ..
Virtual hosts:
  default_host
    *:53101
    *:53103
    *:53116
    *:53117
    *:443
  admin_host
    *:53102
    *:53104
  ..
Additional ports:
  53105  BOOTSTRAP_ADDRESS port
  53106  SOAP_CONNECTOR_ADDRESS port
  53107  SAS_SSL_SERVERAUTH_LISTENER_ADDRESS port
  53108  CSIV2_SSL_SERVERAUTH_LISTENER_ADDRESS port
  53109  CSIV2_SSL_MUTUALAUTH_LISTENER_ADDRESS port
  53102  WC_adminhost port
  53101  WC_defaulthost port
  53111  DCS_UNICAST_ADDRESS port
  53104  WC_adminhost_secure port
  53103  WC_defaulthost_secure port
  53116  SIP_DEFAULTHOST port
  53117  SIP_DEFAULTHOST_SECURE port
  53112  SIB_ENDPOINT_ADDRESS port
  53113  SIB_ENDPOINT_SECURE_ADDRESS port
  53114  SIB_MQ_ENDPOINT_ADDRESS port
  53115  SIB_MQ_ENDPOINT_SECURE_ADDRESS port
  53110  ORB_LISTENER_ADDRESS port
$ ==>
```

---

## Displaying TCP/IP ports assigned to the profile using IBM Web Administration for i5/OS

In this section, we describe how to find information about which TCP/IP ports are assigned to an application server profile. We use the IBM Web Administration for i5/OS method, which we suggest for users who do not feel comfortable with using Qshell commands.

Complete the following steps to view TCP/IP port information using IBM Web Administration for i5/OS:

1. Open and login to IBM Web Administration for i5/OS as we described in 4.2.1, “Starting IBM Web Administration for i5/OS” on page 89.
2. Click the **IBM Web Administration for i5/OS** link. A window similar to Figure 4-57 is displayed.
3. IBM Web Administration for i5/OS contains a set of tabs that allow you to work with different subsets of information. Click the **Manage** tab, as shown in Figure 4-57, to manage the servers that are running on your system.

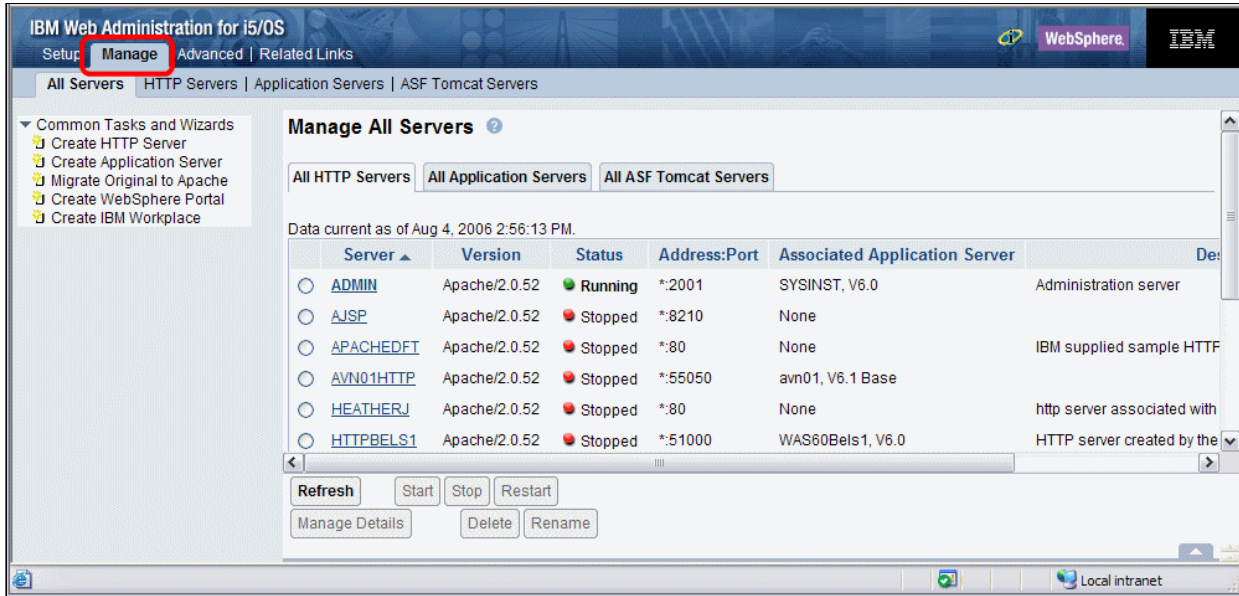

Figure 4-57 IBM Web Administration for i5/OS - Common Tasks and Wizards

IBM Web Administration for i5/OS allows you to work with HTTP servers, WebSphere Application Server, and ASF Tomcat server.

4. Click the **All Application Servers** tab as shown on Figure 4-58 on page 154.

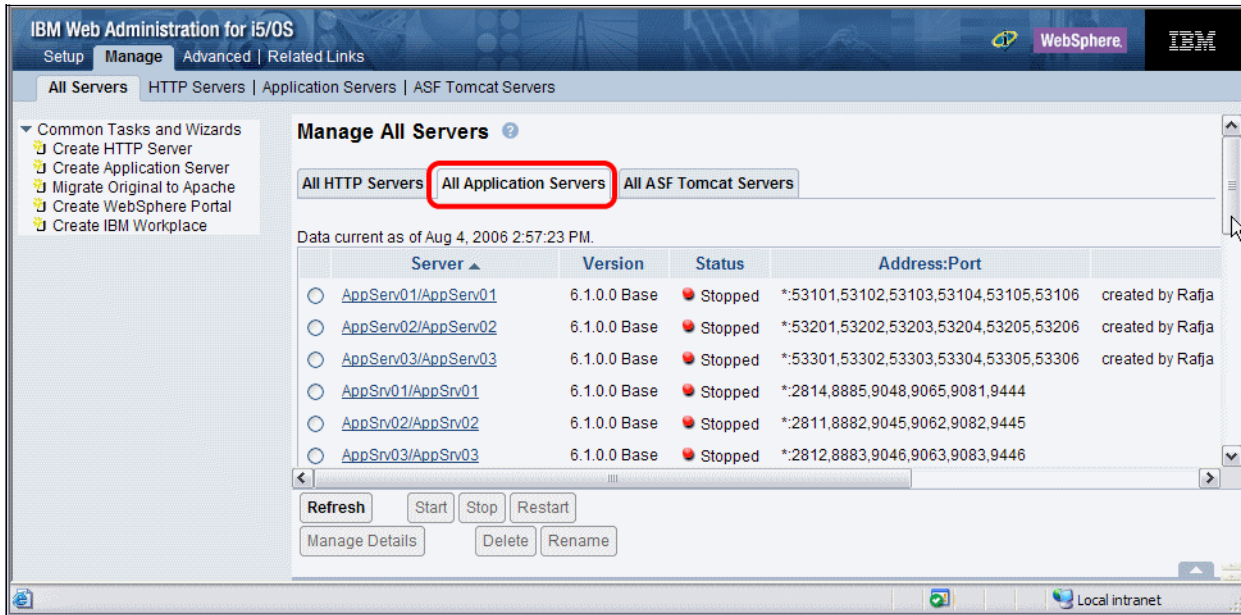

Figure 4-58 IBM Web Administration for i5/OS - Listing application servers defined

- Figure 4-59 shows the list of all application servers profiles that are defined on the system. Find the profile you want to work with, and click the profile name.

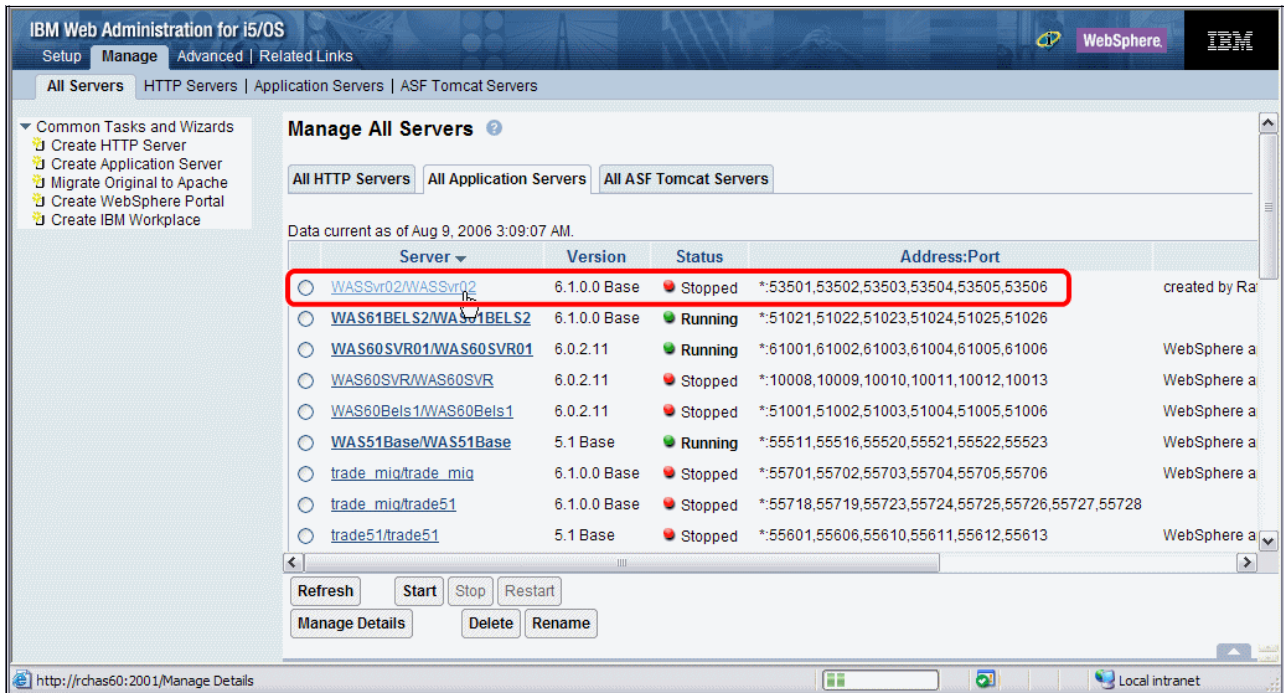

Figure 4-59 IBM Web Administration for i5/OS - Application server entry

- Expand the **Server Properties** group on the left of the window, and click **Server Ports** (Figure 4-60).

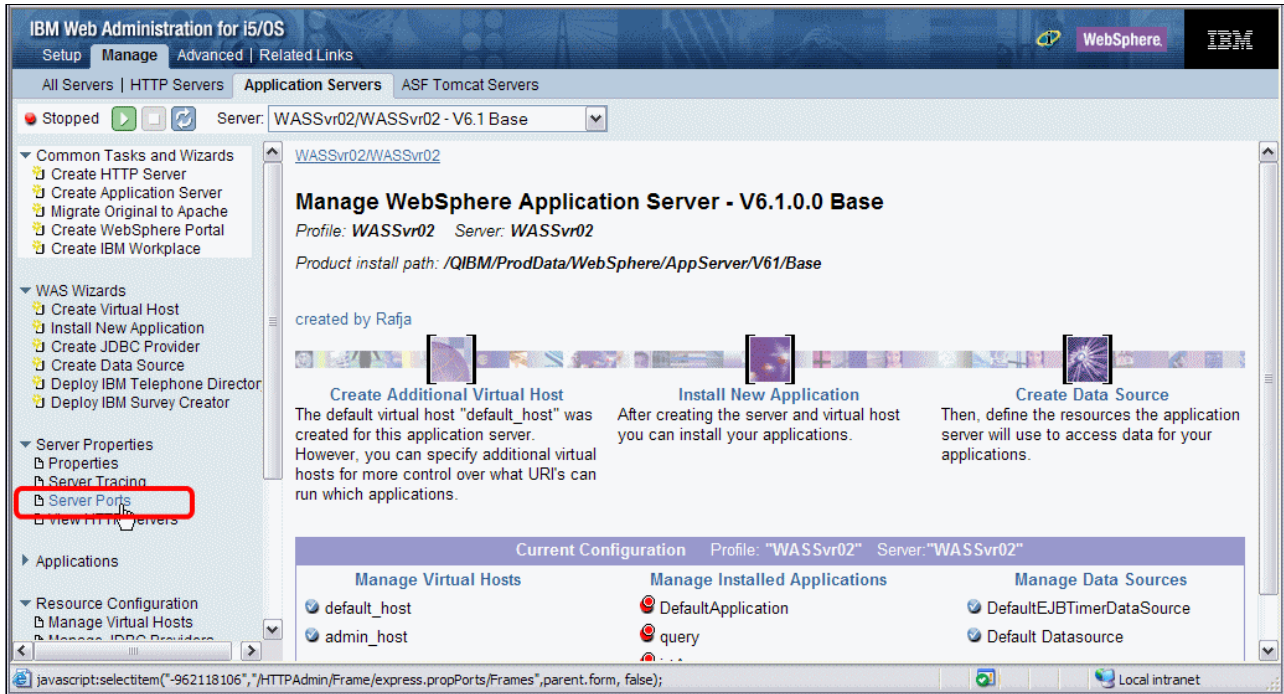

Figure 4-60 IBM Web Administration for i5/OS - Server properties submenu

Using the Server Ports section, get familiar with the TCP/IP ports that are assigned to the particular WebSphere profiles. The window presents a table with port numbers and their corresponding services as shown in Figure 4-61. You can also click the question mark to get more information about the services that are running on the particular ports.

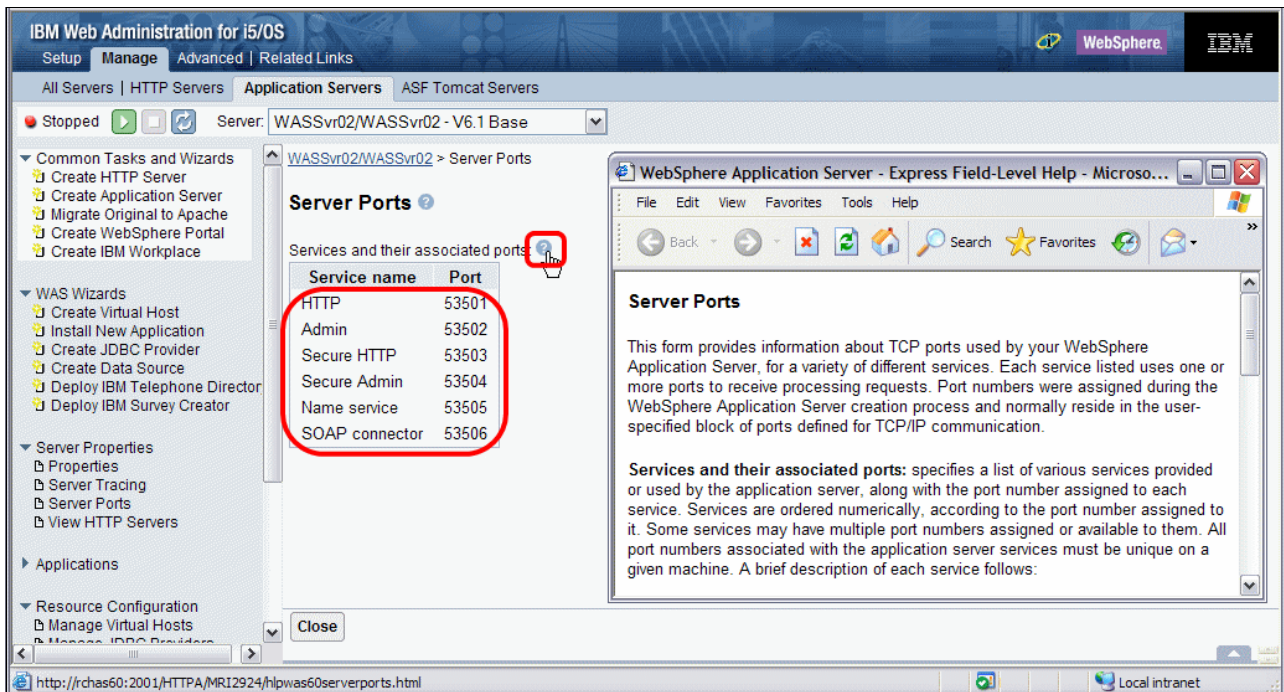

Figure 4-61 IBM Web Administration for i5/OS - Server Ports page

**Attention:** IBM Web Administration for i5/OS shows a subset of the ports, which are usually the only ports you need to know about for day-to-day operations.

## 4.2.12 Working with virtual hosts

A *virtual host* is a configuration that enables a single host machine to resemble multiple host machines. It consists of a host alias or aliases. Each alias is represented by a host name and port number. If you specify an asterisk (\*) as a host name, all of the host names and IP addresses that the Web server can receive are mapped to that virtual host.

There are three virtual hosts defined during installation: `default_host`, `admin_host` and `proxy_host`:

- ▶ The *default\_host* virtual host is intended for access to user applications, either through the WebSphere built-in HTTP transport or through a Web server. At installation time, it is configured as the default virtual host for the application server. It is configured to match requests to ports 80, 9080, and 9443 for any host name.
- ▶ The *admin\_host* virtual host is used to access the WebSphere administrative console. It is configured to match requests to the secure ports 9090 (built-in HTTP transport) and 9043 (Web server) for any host name.
- ▶ The *proxy\_host* virtual host includes default port definitions, ports 80 and 443, which are typically initialized as part of the proxy server initialization. Use this proxy host as appropriate with routing rules associated with the proxy server.

When you install an application, you associate a virtual host with each Web module in the application. By associating a virtual host with a Web module, you create a rule for how this module is accessed. Only those machines that are listed in the virtual host alias table can access resources in that Web module. This configuration information is also copied to the Web server plug-in configuration file, which is how the Web server knows what resources (JSPs, servlets, and so on) are available in the associated application server. Any request to a resource that is not listed in the plug-in configuration file returns a “not found” error.

### Creating a virtual host

By default, `default_host` is associated with all user application requests. There are some cases in which you create multiple virtual hosts, for example:

- ▶ Applications having conflicting URIs
- ▶ Support for extra ports, such as port 443 for SSL
- ▶ Keep clear independence of each virtual host for applications and servers

The configuration of a virtual host is applied to an entire cell. To create a new virtual host:

1. Start the WebSphere administrative console for the deployment manager. Refer to 4.2.6, “Accessing the WebSphere Administrative Console” on page 121 if you are unsure how to do this.

The procedure for creating a new virtual host is the same in stand-alone and deployment manager servers.

2. Select **Environment** → **Virtual Hosts**, and click **New**, as shown in Figure 4-62.

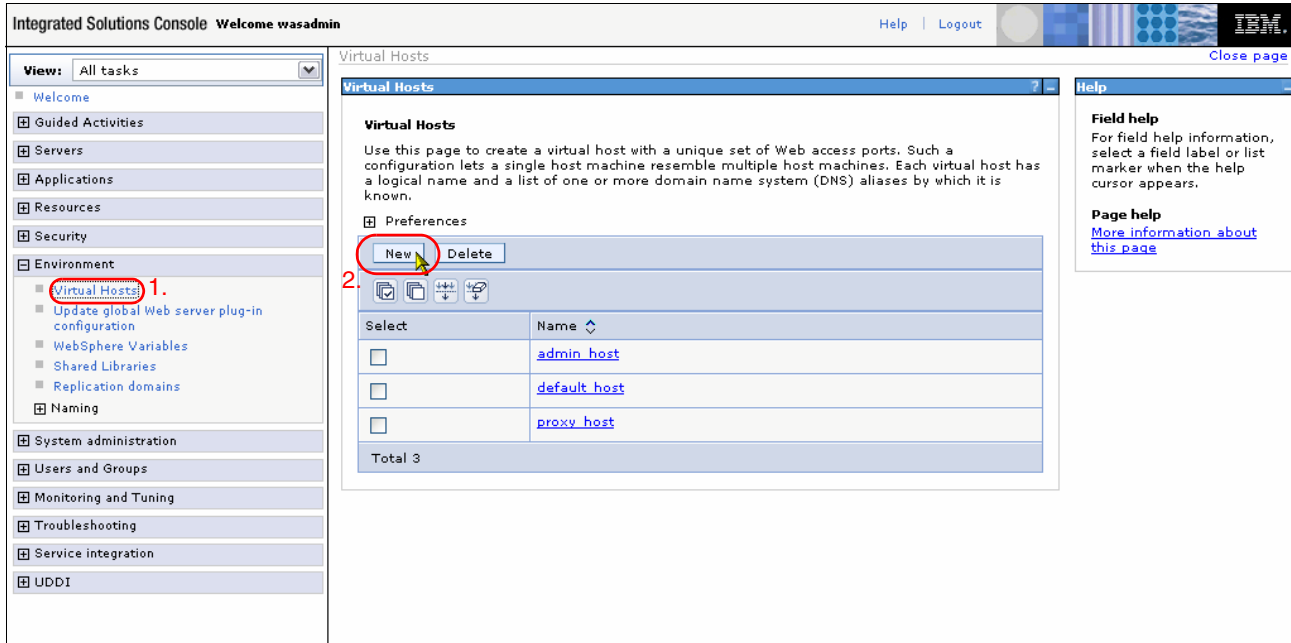

Figure 4-62 Selecting to create a new Virtual Host

3. Enter a name for the Virtual Host, and click **Apply**, as shown in Figure 4-63.

4. Click **Host Aliases** in the Additional Properties pane, as shown in Figure 4-63.

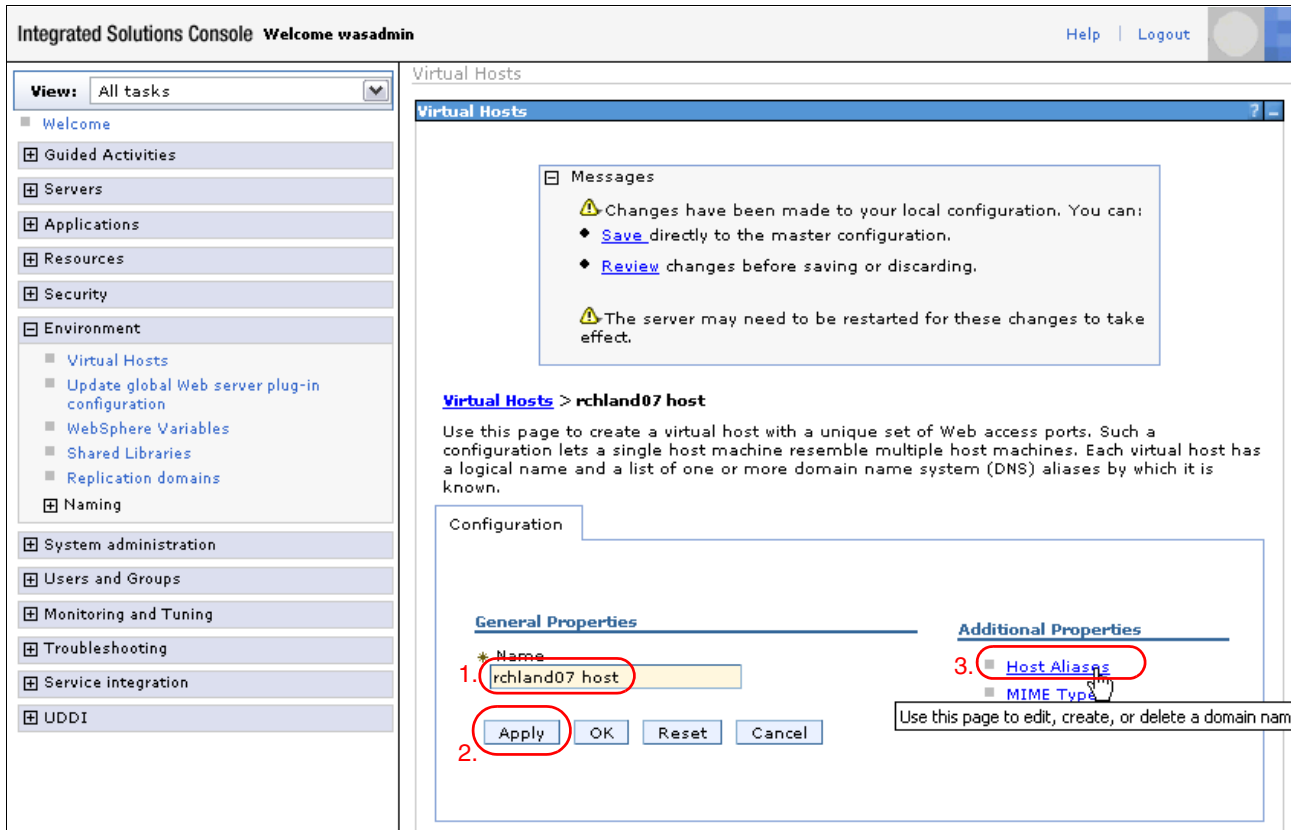

Figure 4-63 Entering the Virtual Host name

5. Click **New**, and enter values for the Host Name and Port fields, as shown in Figure 4-64.
6. Click **OK**, and click **Save** to store the changes, as shown in Figure 4-64.

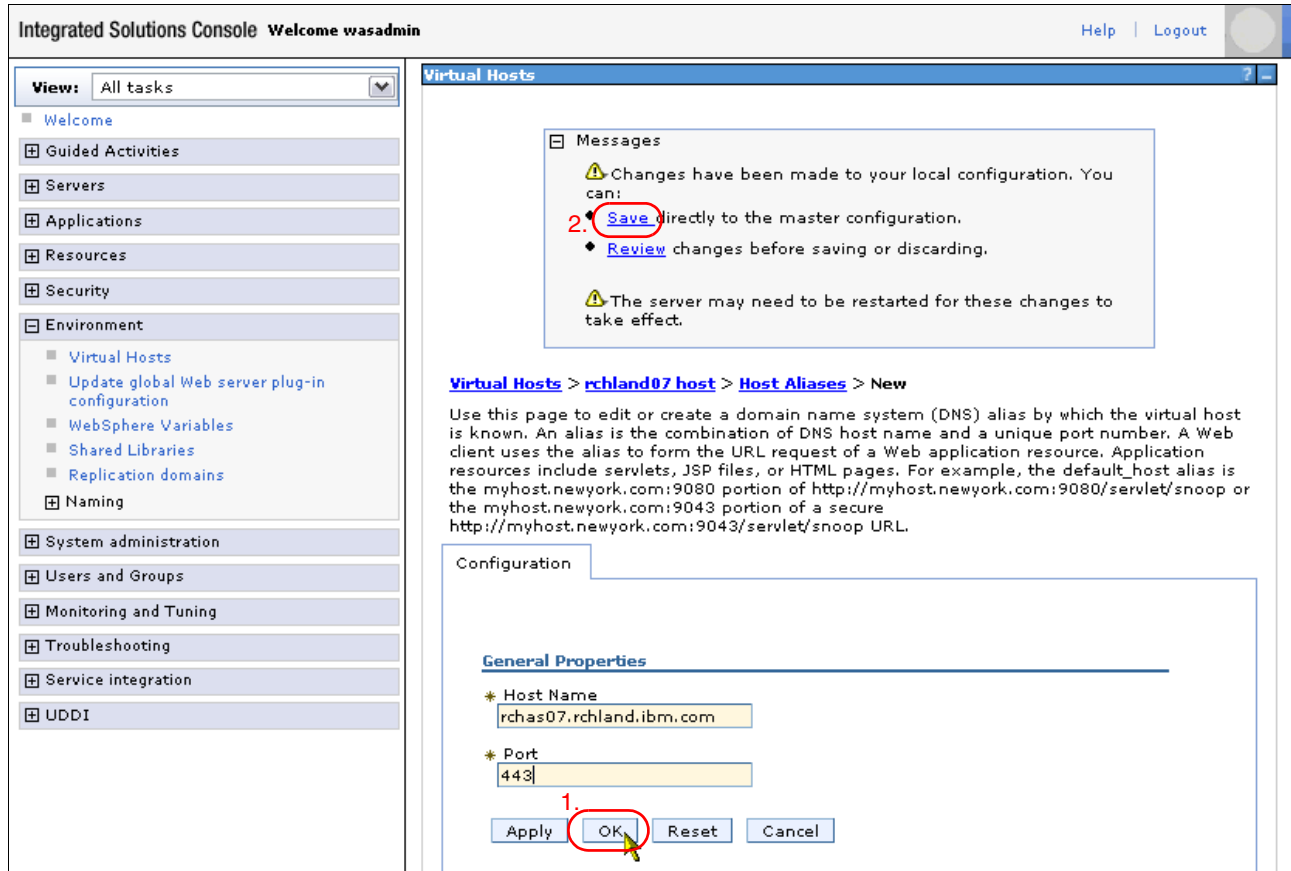

Figure 4-64 Entering the host alias hostname and port

The host aliases are not necessarily the same as the host name and port number of the WebSphere Application Servers. They are the host names and port numbers that the Web server plug-in is expecting to receive from the browser. The Web server plug-in sends the request to the application server using the host name and port number in the transport setting for that Web server. If the Web server is running on a separate machine from WebSphere, the host aliases are for Web server machines.

Mapping HTTP requests to host aliases is case-sensitive and the match must be alphabetically exact. Also, different port numbers are treated as different aliases, for example, the request `http://www.myhost.com/myservlet` does *not* map to any of the following:

```
http://myhost/myservlet
http://www.myhost.com/MyServlet
http://www.myhost.com:9876/myservlet
```

If the Web server plug-in receives a request that does not match one of the virtual hosts, then an HTTP error is returned to you.

You can use simple wild cards on the host aliases. You can use a "\*" for the host name, the port, or both, which means that any request will match this rule. However, we do not recommend that you use a wild card on a production server.

**Important:** If you create, delete, or update virtual hosts, you need to regenerate the Web server plug-in.

### 4.2.13 Auto-starting WebSphere Application Server

The WebSphere Application Server product runs in its own subsystem, QWAS61, which is installed with the product. For each WebSphere Application Server profile, the number of jobs that run in the QWAS61 subsystem depends on which product and which services you are using.

The auto-start of the application servers can be divided into two actions:

- ▶ Automatically start the subsystem
- ▶ Modify the subsystem and corresponding objects

In this section, we concentrate on the task of configuring the QWAS61 subsystem in such a way that after it is started, the application servers are also started.

**Important:** The default application server does not automatically start when the QWAS61 subsystem is started. When you use the startServer Qshell script to start your server, the QWAS61 subsystem is started if it is not currently active.

Table 4-9 lists the parameters that we used in this example.

Table 4-9 The manageprofiles parameters

Parameter name	Sample value	Description
profileName	MyAppSvr01	The name of the profile
serverName	MyAppSvr01	The name of the server
mywaslib	RAFJA	The name of the library, where the copy of the job description object is located
myjobd	MyAppSvr01	The name of the job description duplicate object

**Note:** On i5/OS, by default the application server name is the same as the profile name.

Perform the following steps to configure the application server profile to start automatically after the QWAS61 subsystem is started:

1. Make sure your user profile has authority to access the QWAS61/QWASJOB job description and QWAS61/QWAS61 subsystem description.
2. Create a duplicate of the job description that the WebSphere Application Server profiles use. Issue the following command on the CL command line, where *<mywaslib>* is the library name that contains the job description object, and *<myserv>* is the name of the job description duplicate object:

```
CRTDUPOBJ OBJ(QWASJOB) FROMLIB(QWAS61) OBJTYPE(*JOB) TOLIB(<mywaslib>)  
NEWOBJ(<myjobd>)
```

- Use the CHGJOB command to change the newly-created job description such that the Request data or command (RQSDTA) field starts the new server, for instance, to start the MyAppSvr01 profile's application server (MyAppSvr01) when the QWAS61 subsystem is started, set the RQSDTA field by issuing the following command on the CL command line:

```
CHGJOB JOB(RAFJA/MYAPPSVR01)
```

After you type this command, press F4. Figure 4-65 shows the results that you see.

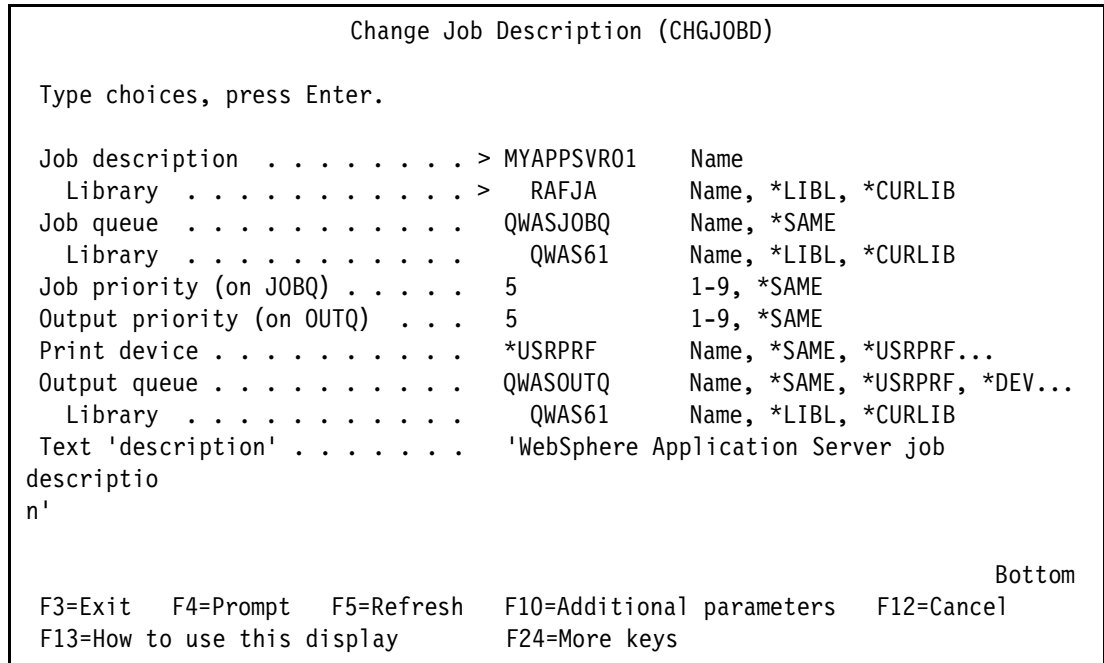

Figure 4-65 Change Job Description panel

- To change the Request Data parameter, you have to switch to Additional parameter mode. Press **F10**, then **PageDown**. Figure 4-66 on page 161 is displayed.

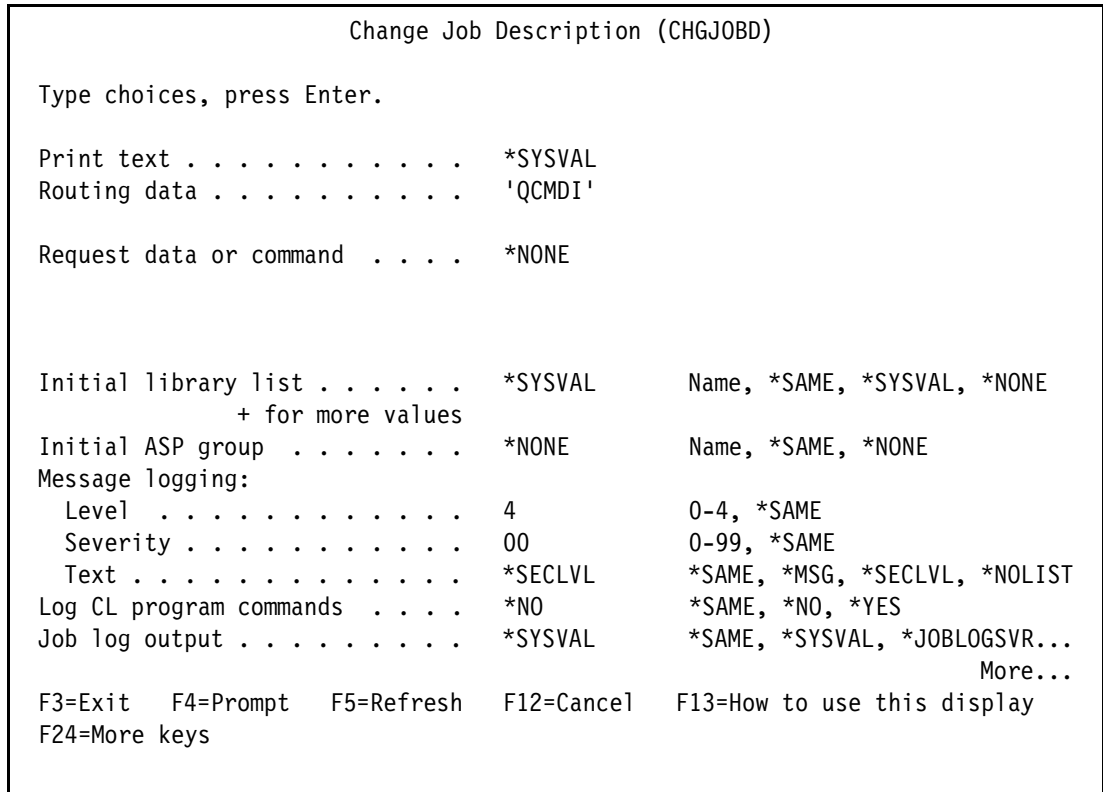

Figure 4-66 Change Job Description panel - Additional parameters

Carefully enter the following in the **Request data or command** input field:

```
'QSYS/CALL PGM(QWAS61/QWASSTRSVR) PARM(''-profilePath''
''/QIBM/UserData/WebSphere/AppServer/V61/Base/profiles/MyAppSvr01'' ''-server''
''MyAppSvr01'')
```

5. Press Enter.
6. Add an autostart job entry to the QWAS61/QWAS61 subsystem.

Type the following command from the CL command line:

```
ADDAJE SBS(D(QWAS61/QWAS61) JOB(MyAppSvr01) JOBD(RAFJA/MyAppSvr01)
```

**Tip:** Optionally, configure the system such that the QWAS61 subsystem starts during system startup. To enable automatic startup of the QWAS61 subsystem, add the following line to the system startup program:

```
STRSBS QWAS61/QWAS61
```





## Working with HTTP servers in WebSphere Application Server environment

In this chapter, we focus on the support for Web servers and in particular IBM HTTP Server in WebSphere Application Server V6.1. We arranged this chapter as a set of self-contained examples that allow you to understand the configuration of the HTTP servers in different WebSphere Application Server topologies.

**Note:** We use the terms “HTTP server” and “Web server” interchangeably.

## 5.1 Overview of Web servers in a WebSphere Application Server environment

A Web server can serve requests that do not require any dynamic content, for example, HTML pages. However, when a request requires dynamic content, such as JavaServer Pages (JSP) or servlet processing, it must be forwarded to WebSphere Application Server for handling.

To forward a request, an HTTP server uses a Web server plug-in, which is included with the WebSphere Application Server products. There is a separate version of a Web server plug-in for each supported Web server and operating system. The plug-in uses an XML configuration file to determine whether a request is handled by the Web server or an application server. The plug-in supports HTTP or HTTPS to transmit the request.

When you configure a Web server with WebSphere Application Server, it is defined to the WebSphere administration as a *Web server node*. Web server nodes can be *managed* or *unmanaged*. Managed nodes have an additional agent called a node agent, which is running on the Web server machine. This agent enables the Deployment Manager to administer the Web server, for example, you can start or stop the Web server from the Deployment Manager, generate the Web server plug-in configuration file, and automatically push it to the Web server.

Unmanaged Web server nodes, as the name implies, are not managed by WebSphere Application Server. When a Web server is installed on a separate machine from the WebSphere machine, you must manually copy or FTP Web server plug-in configuration files to the Web server. However, there is a special case for the IBM HTTP Server product and we explain it in 5.3, “Configuring a remote Web server with WebSphere Application Server” on page 171.

We describe a Web server configuration that is based on a chosen WebSphere topology. Topology refers to what devices and servers are going to be used to set up a Web serving environment—the physical layout of each server and the relationship between them. When you select a topology, there are a number of criteria for you to consider; however, such criteria are outside of the scope of this book. For a discussion on choosing a topology, see Chapter 5 of the IBM Redbooks publication *WebSphere Application Server V6.1: Planning and Design*, SG24-7305.

Although there are various criteria that ultimately influence your choice of topology, one important consideration is whether the Web server is *local* or *remote* to the WebSphere Application Server node.

**Attention:** If you are configuring a Web server on the same i5/OS server or logical partition as your WebSphere Application Server (that is, the Web server is local), you do not need to install the Web server plug-in.

However, if you are running your Web server on a different i5/OS system or logical partition to the application server (that is, the Web server is remote), you must install a Web server plug-in for your Web server. If you are using a Web server on a non-i5/OS platform, the plug-in installation and configuration are slightly different and we do not cover it in this book. Refer to the documentation on installing Web server plug-ins for the platform that you are using.

If you plan to use a local Web server with WebSphere Application Server, read on; otherwise, if you want to configure WebSphere Application Server to use a Web server that is installed

on a separate, remote i5/OS server, you might want to skip to section 5.3, “Configuring a remote Web server with WebSphere Application Server” on page 171.

### 5.1.1 Local Web server topology (stand-alone server)

There are various architectures or topologies for a WebSphere Application Server environment. In this section, we concentrate on a scenario where IBM System i platform fits well. Figure 5-1 outlines the components and relationships in a basic single-server architecture.

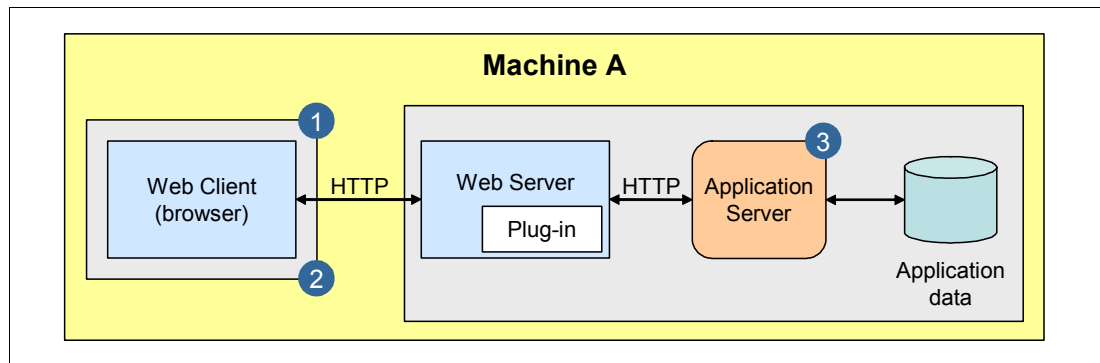

Figure 5-1 Typical Web serving architecture using a local Web server

The topology consists of the following components:

- ▶ Web browser: acts as a Web client. In most cases, it is a thin client that sends HTTP requests to the Web server.
- ▶ Web server: in the early ages of the internet, the Web (or HTTP) server was the key and sometimes the only server in the whole environment. In our architecture, it has two main tasks to perform:
  - The first is to serve traditional static Web content, such as HTML pages, image files, and so on.
  - The second and most important, from our perspective, is to redirect some of the HTTP requests to the application server.

In Figure 5-1, the Web server is labeled 1.

- ▶ Web server plug-in: a Web server serves static content; however, quite often it can also serve dynamic content through application server plug-ins. To establish a communication path between the Web server and the application server, you need a special program that acts as “glue code” between these two components. In Figure 5-1, the plug-in is labeled 2.
- ▶ Application server: usually a J2EE-compliant application server, such as WebSphere Application Server. In general, this component is responsible for serving dynamic content; however, the capabilities of current application servers are more extensive than this. In Figure 5-1, the application server is labeled 3.
- ▶ Application data: represents a database that the J2EE applications use, which runs inside the application server. In this book, we use DB2 UDB for i5/OS, which is integrated with i5/OS.

The main reason for putting the Web server, application server, and database components of our architecture on the same physical server is the IBM System i ideology of *integration*. From the ground up, System i is built for high performance and integrated computing. To that end, DB2/UDB for i5/OS, WebSphere Application Server Express, and IBM HTTP Server (based on Apache) are all included on the System i server, which means that all of the

components that you need to set up a reliable application serving environment are already included with i5/OS.

To make communication between the Web server and application server possible, both of these components must be configured properly. In 5.2, “Configuring a local Web server with WebSphere Application Server” on page 167, we discuss the configuration that is required for a stand-alone topology.

### 5.1.2 Remote Web server topology (stand-alone server)

Figure 5-2 illustrates the alternative location of the Web server, which is on a remote system. You can isolate the remote Web server from the application server by using a firewall or other methods.

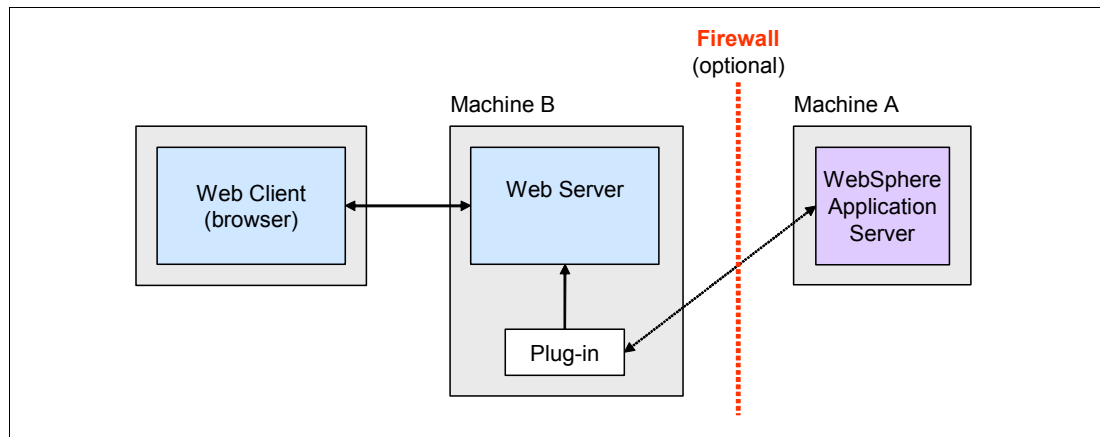

Figure 5-2 Remote Web server topology using stand-alone application server node

Security is the primary reason for considering a topology with a remote Web server. Such a configuration provides separate Web server and WebSphere interfaces to protect the application servers from unauthorized access. Separation of the Web server from the application server is often achieved using firewalls to create a secure dematerialized zone (DMZ) surrounding the Web server. Isolating the Web server in a DMZ protects the application logic and data by restricting the access from the public Web site to the servers and databases where this valuable information is stored. However, it is not usually advisable to run WebSphere Application Server in the DMZ because WebSphere Application Server usually needs to access a database that is located on a private or isolated portion of the network. For performance reasons, WebSphere Application Server should be “close” to the data that the enterprise applications access.

Another possible motive for using a remote Web server is to remove resource contention. By installing the Web server on a separate machine from WebSphere Application Server, a high load of static requests (for example, for HTML pages or image files) does not affect the resources available to WebSphere, such as processor, memory, and disk. Therefore, WebSphere Application Server’s ability to service dynamic requests is not affected by fluctuations in the number of static requests fulfilled by the remote Web server. The same applies when the Web server serves dynamic content using other technologies, such as CGI and so on.

In this scenario, the Web server plug-in must be installed on the remote Web server as a separate step from WebSphere Application Server installation. See 5.3, “Configuring a remote Web server with WebSphere Application Server” on page 171 for more information.

## 5.2 Configuring a local Web server with WebSphere Application Server

In this section, you can find detailed instructions on how to configure IBM HTTP Server for i5/OS and WebSphere Application Server to work together in a stand-alone topology with a local Web server, as we described in 5.1.1, “Local Web server topology (stand-alone server)” on page 165.

As a starting point, for this example we already created a Web server instance and a WebSphere Application Server profile.

Before you can proceed, you must identify some of the initial configuration parameters that the Web server and the application server will use. Table 5-1 lists HTTP Server parameters. Table 5-2 summarizes the application server profile parameters.

Table 5-1 HTTP Server instance parameters

Parameter name	Sample value	Description
Instance name	HTTP01	HTTP server instance name
Port	80	Port number the HTTP server listens on

Table 5-2 WebSphere Application Server profile parameters

Parameter name	Sample value	Description
Profile name	App01	Application server profile name
Template path	default	Directory path to the template files
Admin port	20001	Starting port of the port block that this profile uses

In the following example, we use IBM Web Administration for i5/OS and the WebSphere administrative console, which are our main administrative interfaces.

Complete the following steps to configure the local Web server to communicate with WebSphere Application Server:

1. Open IBM Web Administration for i5/OS, and click the **Manage** tab and **HTTP Servers** subtab.
2. Select the HTTP server instance you want to work with.

**Note:** See 4.2.1, “Starting IBM Web Administration for i5/OS” on page 89 for information about how to start this application.

3. Click the **WebSphere Application Server** link, as shown in Figure 5-3 on page 168.
4. Select the **WebSphere Application Server, V6.1 Base** option, and choose the application server profile you want associated with the current HTTP server instance. There are two more menus present, which allow you to:
  - Map all applications that are installed in the selected application server profile to the current HTTP server instance.
  - Choose to start the selected application server profile when ever the current HTTP server instance is started.
5. Choose **All applications** to be mapped, leave the second menu set to **No**, and click **OK**.

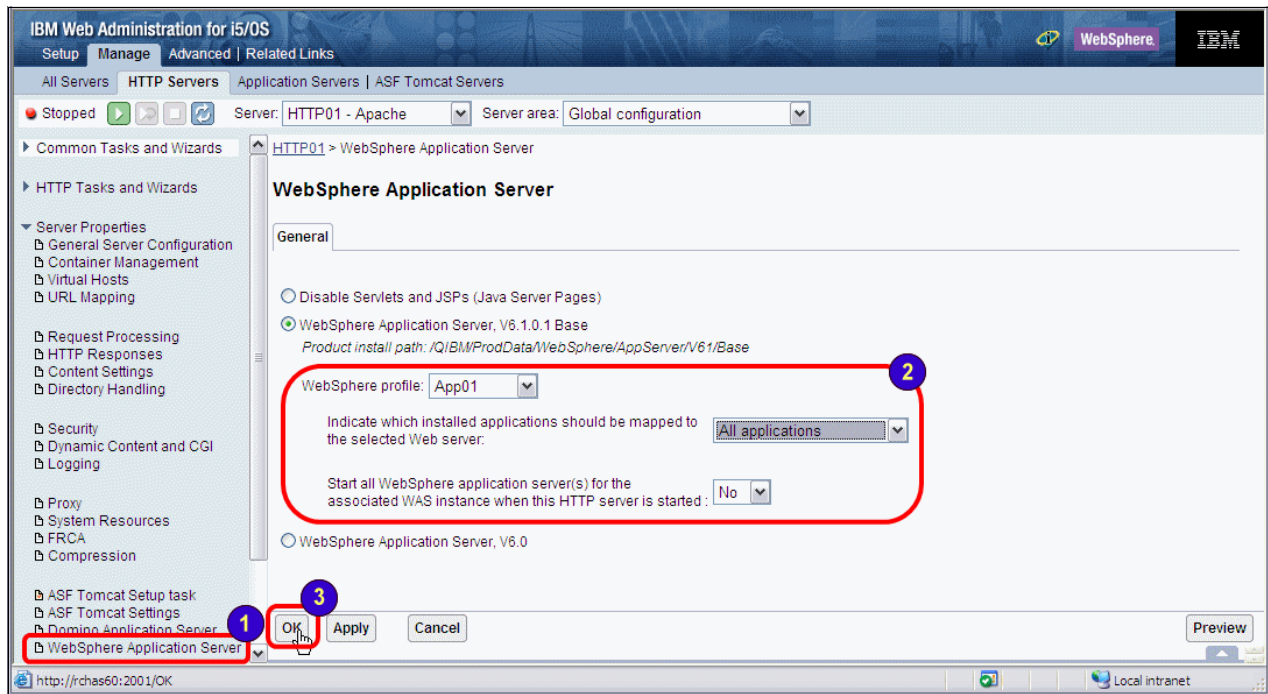

Figure 5-3 IBM Web Administration for i5/OS - associating application server with HTTP server

6. To verify that the association was performed correctly, click **Tools** → **Display Configuration File** as shown in Figure 5-4 on page 169.

To associate the Web server and the application server, the wizard adds two more lines at the beginning of the Web server configuration file. These two lines provide the Web server with the location of the plug-in configuration XML file and the location of the plug-in executable code.

The plug-in configuration XML file is located under the directory structure of the application server profile. The plug-in code is a service program located in the WebSphere Application Server library.

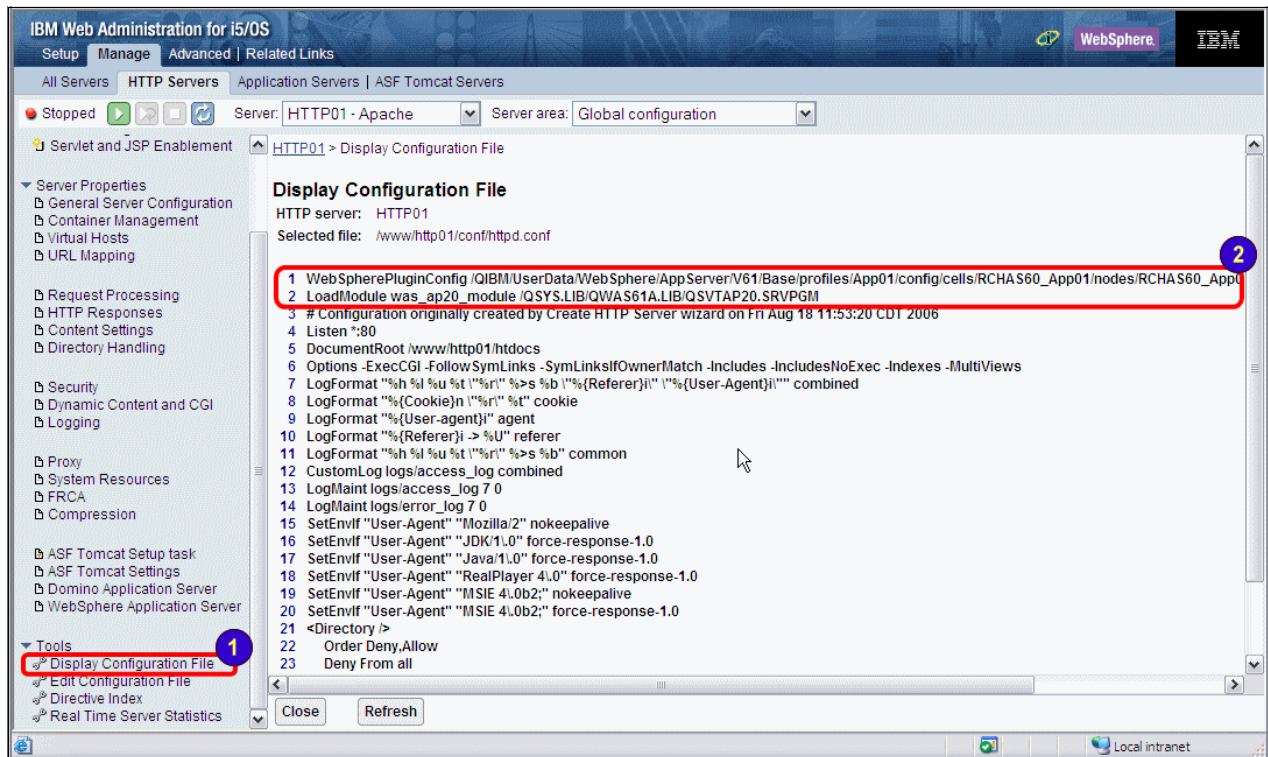

Figure 5-4 IBM Web Administration for i5/OS - parameters added to HTTP server configuration file

- Based on the parameters specified in step 6 (Figure 5-3 on page 168) the wizard sets up the HTTP Server side as well as the application server side. On the application server side, the wizard creates a *Web server definition* (Figure 5-5 on page 170) in the WebSphere Administrative Console.

The Web server definition is an object that represents the Web server in the WebSphere application server profile. The Web server definition allows for the remote administration of the Web server from the administrative console.

Open the WebSphere Administrative Console as described in 4.2.6, “Accessing the WebSphere Administrative Console” on page 121. Click **Servers** → **Web servers**, as shown on Figure 5-5 on page 170. The Web server definition list is displayed. You can see one entry that represents the Web server that is associated with the application server profile.

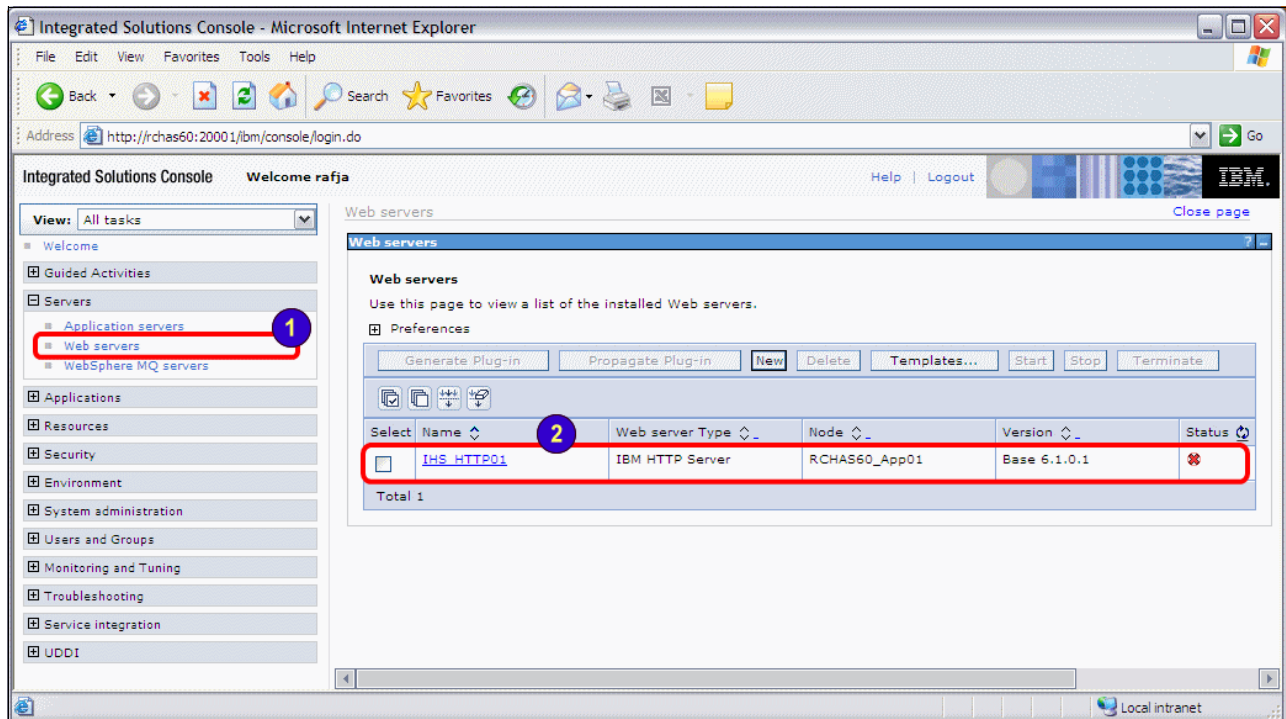

Figure 5-5 Administrative console - Web server definitions

8. Click the Web server definition entry (Figure 5-5) to work with the object's configuration parameters as shown in Figure 5-6 on page 171.

**Note:** Depending on the Web server instance name, the window can have one or two tabs. If the Web server instance is in the running state, you will see an additional tab called **Runtime**.

There are several configuration parameters displayed, such as:

- Web server name - logical name of the Web server.
- Type - the vendor of the Web server. The default value is IBM HTTP Server.
- Port - The port from which to ping the status of the Web server.
- Configuration file name - Specifies the location of the Web server instance configuration file.
- Web server Instance name - Specifies the name of the Web server instance

The wizard creates the Web server name based on the HTTP server instance name and adds the prefix. The prefix change depends on the Web server type. For IBM HTTP Server, the prefix is *IHS\_*, which combined with an instance name of HTTP01, creates the Web server name IHS\_HTTP01.

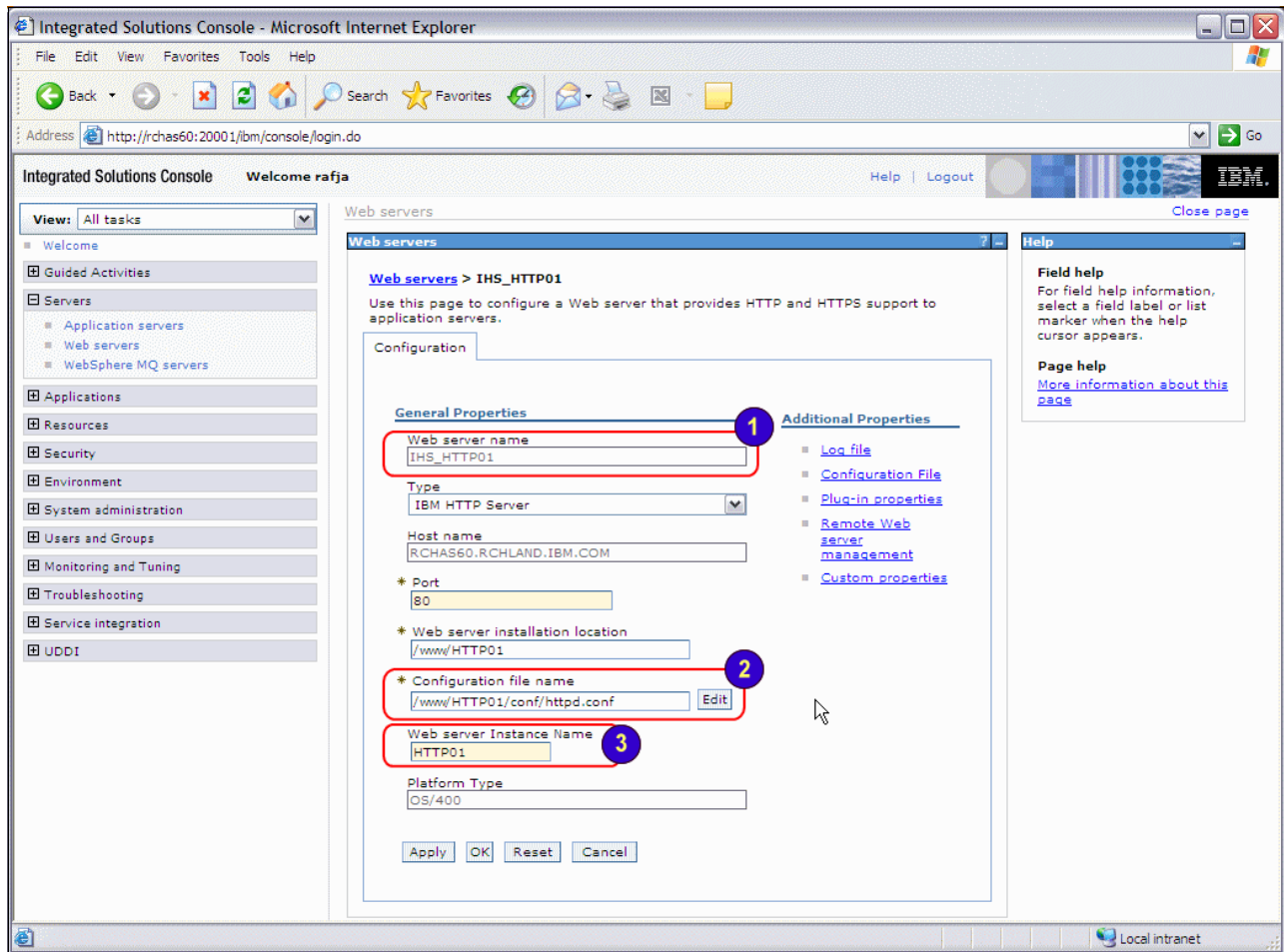

Figure 5-6 Administrative console - Web server definition configuration

In this section, we described how to associate the Web server instance with an application server profile. There are other ways to accomplish this, however IBM Web Administration for i5/OS includes a wizard that creates such an association in a single step.

## 5.3 Configuring a remote Web server with WebSphere Application Server

In this section, we describe the procedure for configuring WebSphere Application Server to work with a Web server that is installed on a remote i5/OS machine (or logical partition) to WebSphere Application Server.

**Attention:** If you are running your remote Web server on a platform other than i5/OS, read the documentation about installing Web server plug-ins for the platform that you are using. The steps in this section are applicable *only* to remote Web servers that are running on i5/OS.

**Important:** In this section, we assume that the WebSphere Application Server profile is a stand-alone server that is not federated into a cell that is managed by WebSphere Application Server Network Deployment. If you intend to federate the WebSphere Application Server profile into a cell, federate the WebSphere Application Server profile *before* you configure it to use a remote Web server. Any Web server definition that is associated with the profile is lost upon federation.

The high-level steps that are required to configure a remote Web server instance to communicate with WebSphere Application Server are (see Figure 5-7):

1. Install the plug-in on the remote Web server Machine B, which we discuss in 5.3.1, “Installing the Web server plug-in on the remote Web server” on page 172.
2. Create a Web server instance on the remote Web server Machine B, which we discuss in see 5.3.2, “Creating an instance of IBM HTTP Server for i5/OS” on page 177.
3. Create a special kind of a WebSphere profile called *http profile*, which we discuss in 5.3.3, “Creating a non-default HTTP server profile” on page 180. This profile is different from the WebSphere profile that is created on the application server Machine A.
4. Associate the Web server instance with the http profile, which we discuss in 5.3.4, “Associating the Web server instance and Web server profile” on page 180.
5. Run a configuration script on the application server machine to update the WebSphere Application Server repository, which we discuss in 5.3.5, “Creating a Web server definition in the WebSphere profile” on page 181.

Step 2 can occur any time prior to step 4, although we performed the steps in the given order. You must perform the other steps in the order listed.

Figure 5-7 illustrates the remote HTTP server configuration.

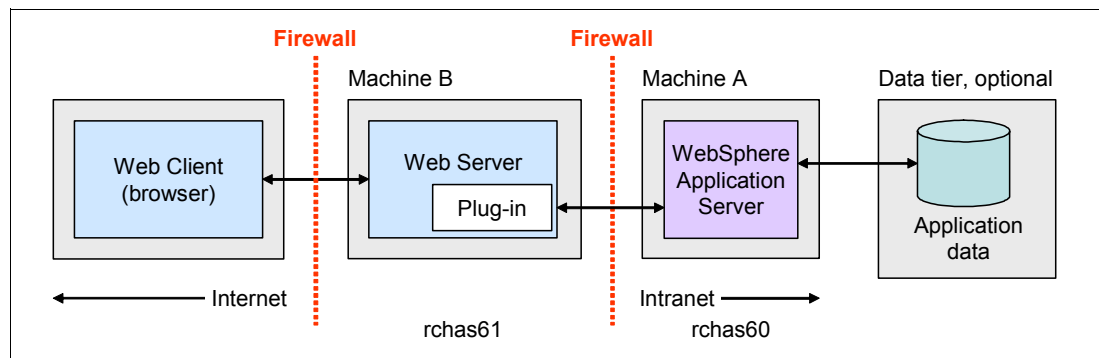

Figure 5-7 Remote HTTP server configuration

In the following sections, we assume that the remote Web server is an IBM HTTP Server for i5/OS.

### 5.3.1 Installing the Web server plug-in on the remote Web server

With a remote Web server, you must install the plug-in on the remote Web server machine as a separate step from WebSphere Application Server installation on the i5/OS. In our scenario, WebSphere Application Server is installed on rchas60, but the Web server is on rchas61, which is a second i5/OS V5R4 server. The Web server is an IBM HTTP Server for i5/OS, which comes pre-installed on i5/OS.

To install the plug-in on the remote Web server using the plug-in installation wizard, complete the following steps on the remote Web server system:

1. Start a 5250 emulator session and sign on.
2. If TCP/IP is not started or if you do not know if TCP/IP is started, enter the Start TCP/IP (STRTCP) command on the Control Language (CL) command line.
3. Verify that the host server jobs are started on your System i server. The host server jobs allow the installation code to run on System i. On a CL command line, type:  
`STRHOSTSVR SERVER(*ALL)`
4. Verify that your user profile has the \*ALLOBJ and \*SECADM special authorities by using `DSPUSRPRF <user_profile>`.
5. Place the WebSphere Application Server Supplemental CD in the disc drive of your workstation.
6. Run the launchpad.exe program, which is available in the root directory of the product disc or the downloaded installation image.
7. Select **Launch the installation wizard for Web server plug-ins**, as shown in Figure 5-8. The launch pad opens in the language of the local setting of the machine.

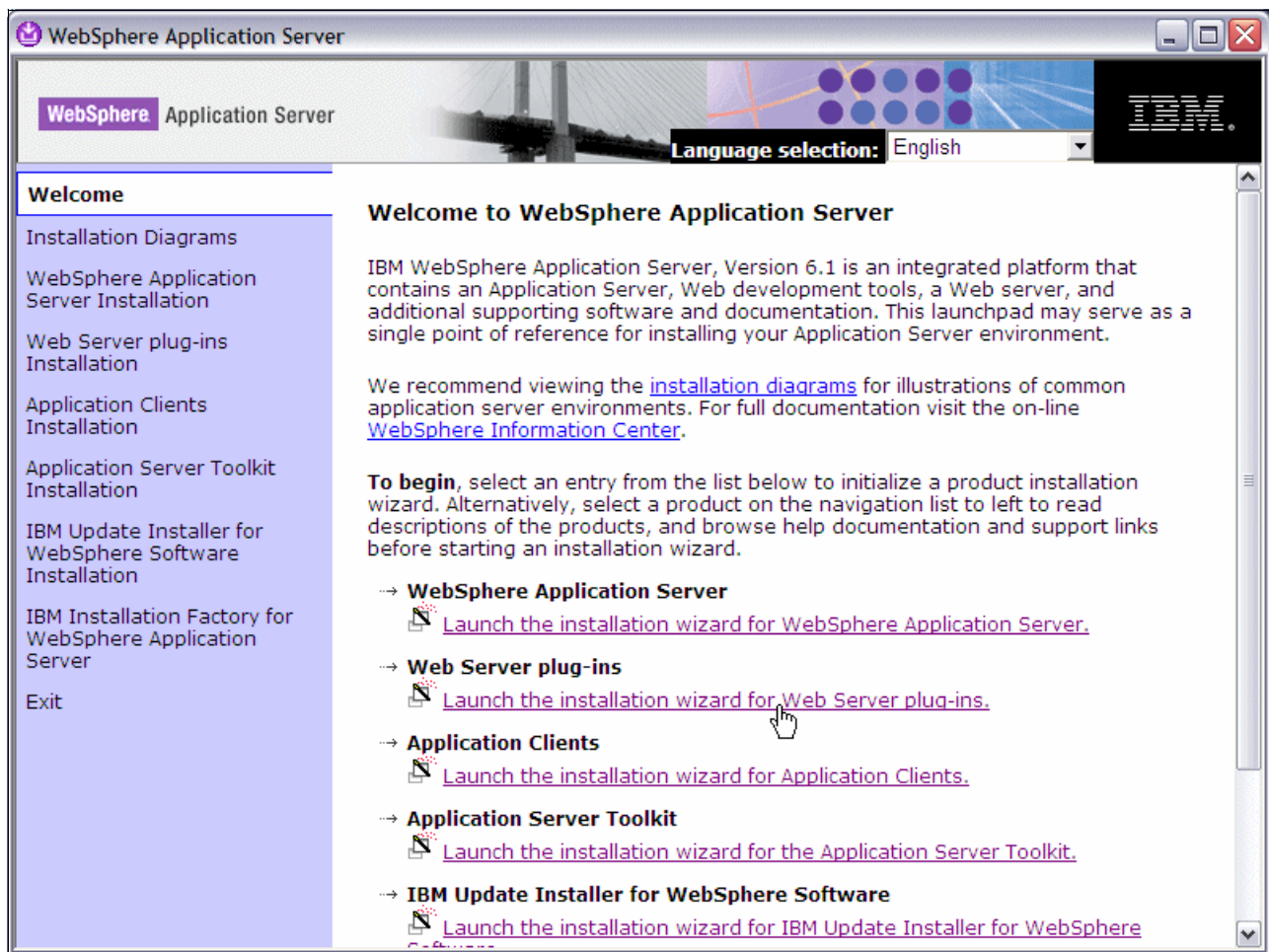

Figure 5-8 Selecting the Web server plug-in installation wizard from the launch pad

8. Enter your user profile, password, and the host name or IP address for the system on which you are installing the plug-in, and then click **OK**, as shown in Figure 5-9.

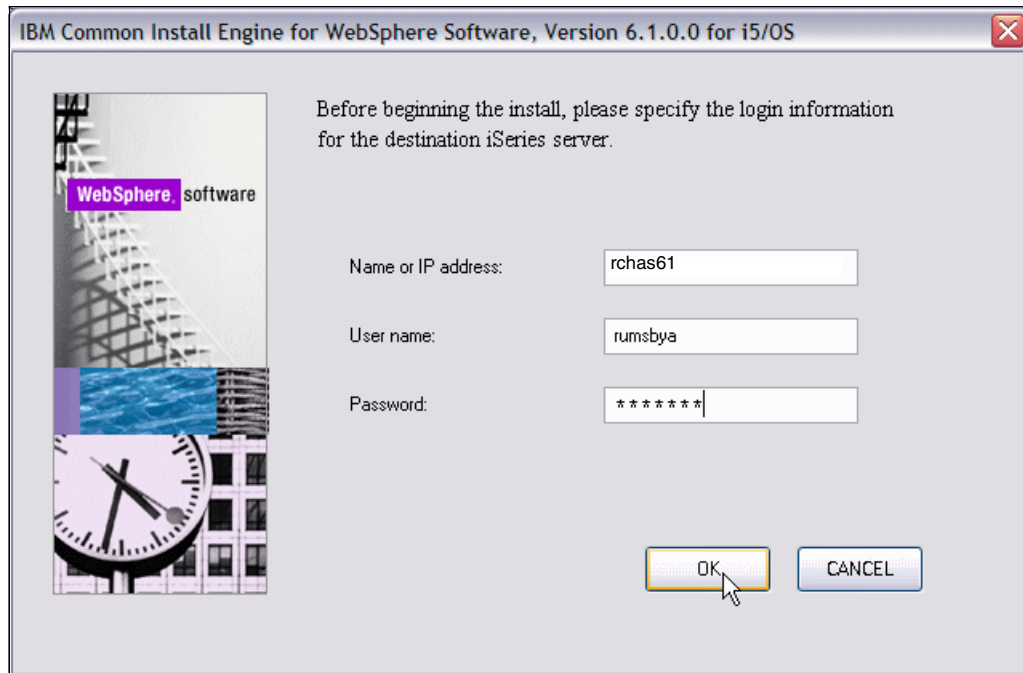

Figure 5-9 Specify the login information for the destination iSeries server

9. The Welcome page for the installer appears, as shown in Figure 5-10. Deselect the **Installation roadmap: overview and installation scenarios** option, and click **Next**.

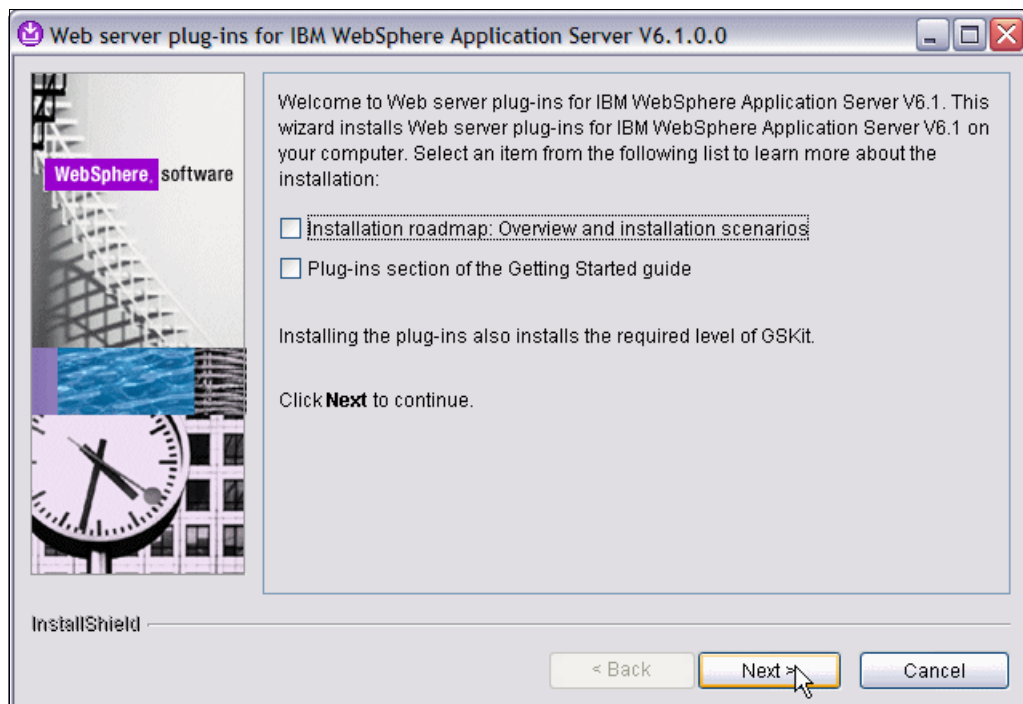

Figure 5-10 Plug-in install wizard Welcome panel

10. On the Software License Agreement panel, select **I accept the terms in the license agreement** message, if you agree to the license agreement, and click **Next** to continue.
- The wizard performs a prerequisites check on the remote i5/OS server where the plug-in is to be installed. After a short time, the success window (Figure 5-11) is displayed.

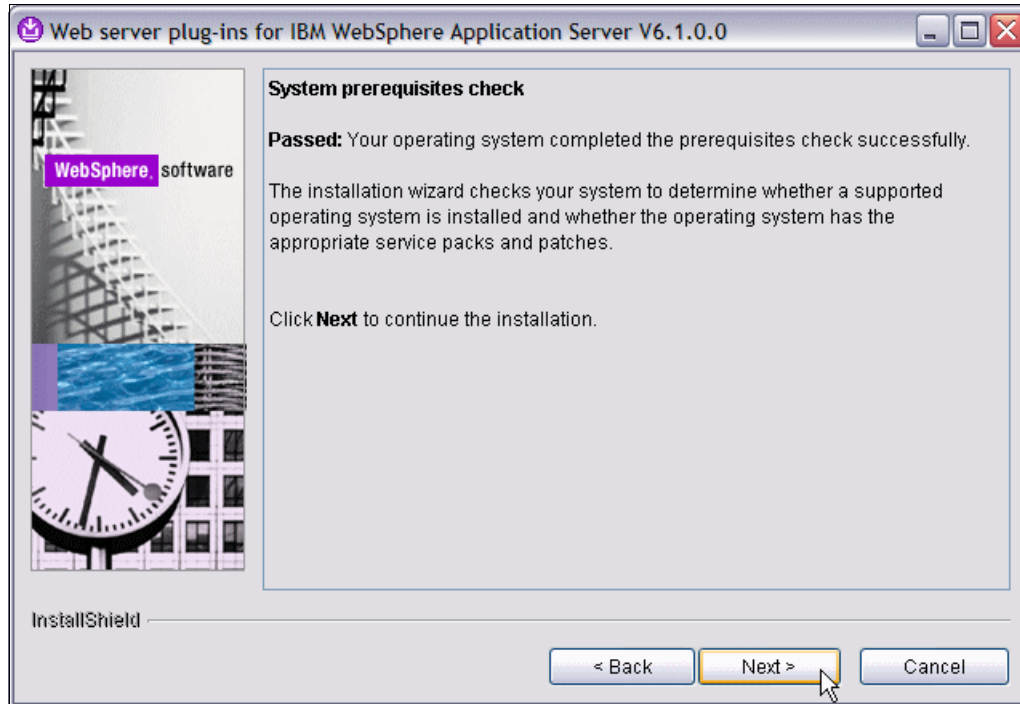

Figure 5-11 Prerequisites check passed

11. If the operating system prerequisite check shows Passed, click **Next**. If the check shows Failed, click **Cancel**. Install any PTFs that are needed for the plug-in, and then try to install the Web server plug-in again.

12. Next, you are prompted to select the Web server to configure. Select **None**, and click **Next**, as shown in Figure 5-12.

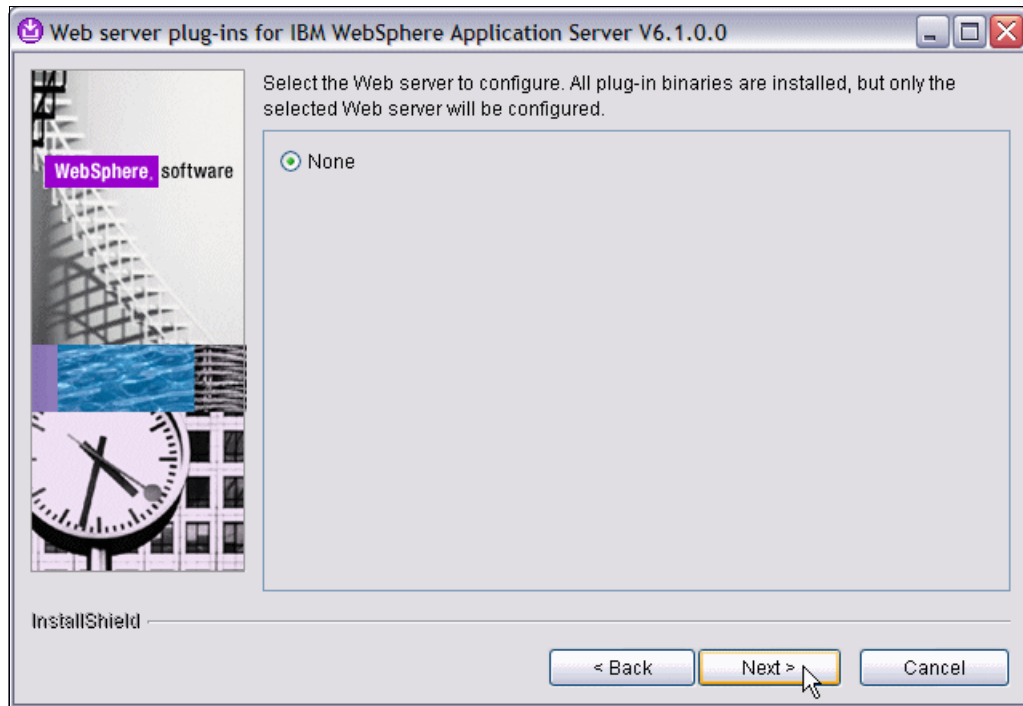

Figure 5-12 Choosing the Web server to configure

13. The Installation directory panel (Figure 5-13) appears. Specify the directories to which to install the plug-in and default profile (or keep the default location as we did). Click **Next**.

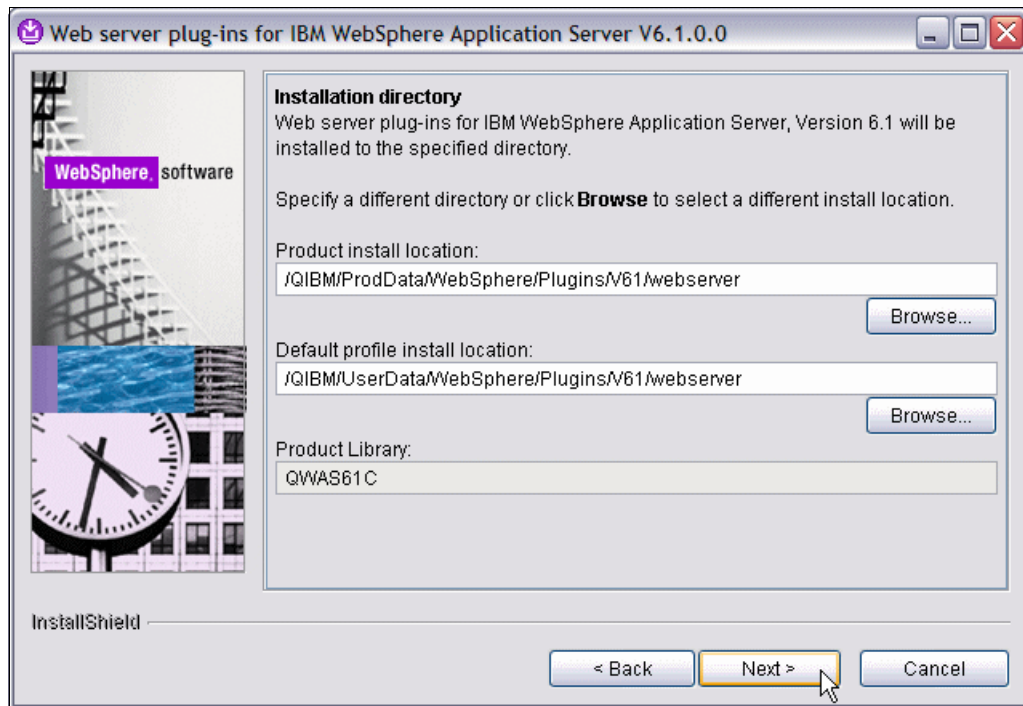

Figure 5-13 Choose install directory for plug-in and default profile

14. On the Installation Summary panel, verify that the settings are correct, and click **Next**.

The installation wizard copies the Web server plug-in files to your system and creates a default Web server profile (called *http*) as a convenience and to act as the location for putting key, certificate, or log files. This takes a few minutes to complete.

15. The installation results panel (Figure 5-14) appears indicating success. Click **Finish** to exit the wizard.

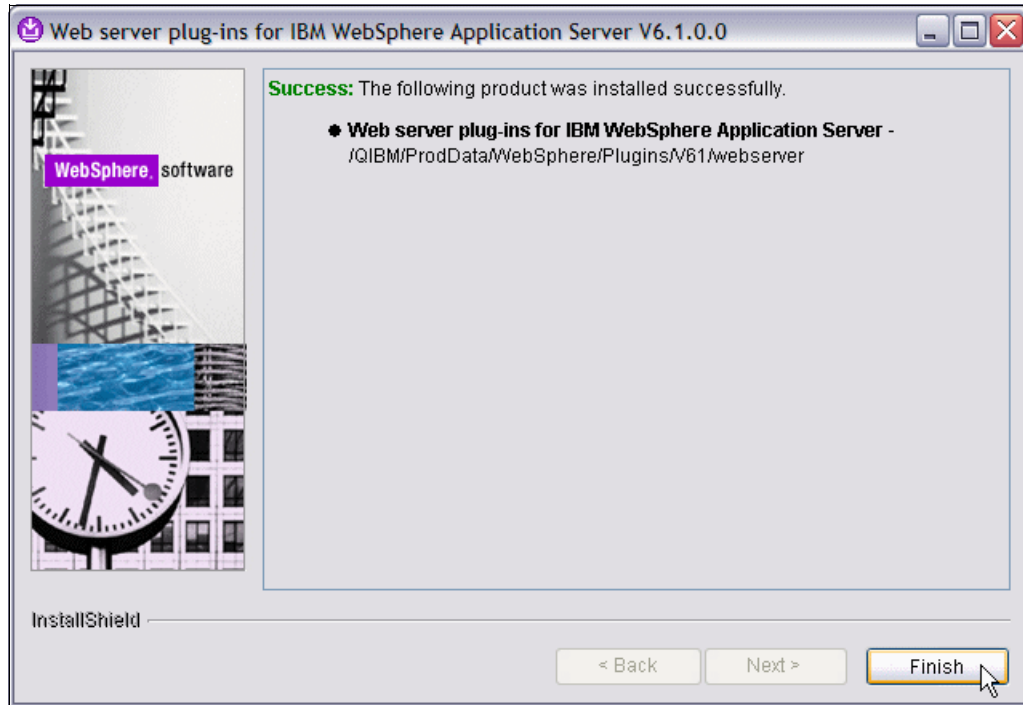

Figure 5-14 Web server plug-in successfully installed to remote System i server

In this section, you installed the Web server plug-in that is required by the remote Web server.

### 5.3.2 Creating an instance of IBM HTTP Server for i5/OS

At this stage, although the IBM HTTP Server for i5/OS product is present on the remote Web server machine (because it ships with i5/OS), there are no instances created. To create an instance of IBM HTTP Server for i5/OS, perform the following steps on the remote Web server machine (Machine B in Figure 5-7 on page 172):

1. Make sure that the \*ADMIN HTTP server is up by issuing the following command at a CL prompt:

```
STRTCPSVR SERVER(*HTTP) HTTPSVR(*ADMIN) .
```

2. Connect to IBM Web Administration for i5/OS on the *remote Web server system* by pointing a browser at the following URL:

```
http://<Remote_Web_server_hostname>:2001/HTTPAdmin
```

**Important:** Make sure you specify the host name of the remote Web server machine, *not* the application server machine.

3. In the left navigation pane, click **Create HTTP Server**, as shown in Figure 5-15.

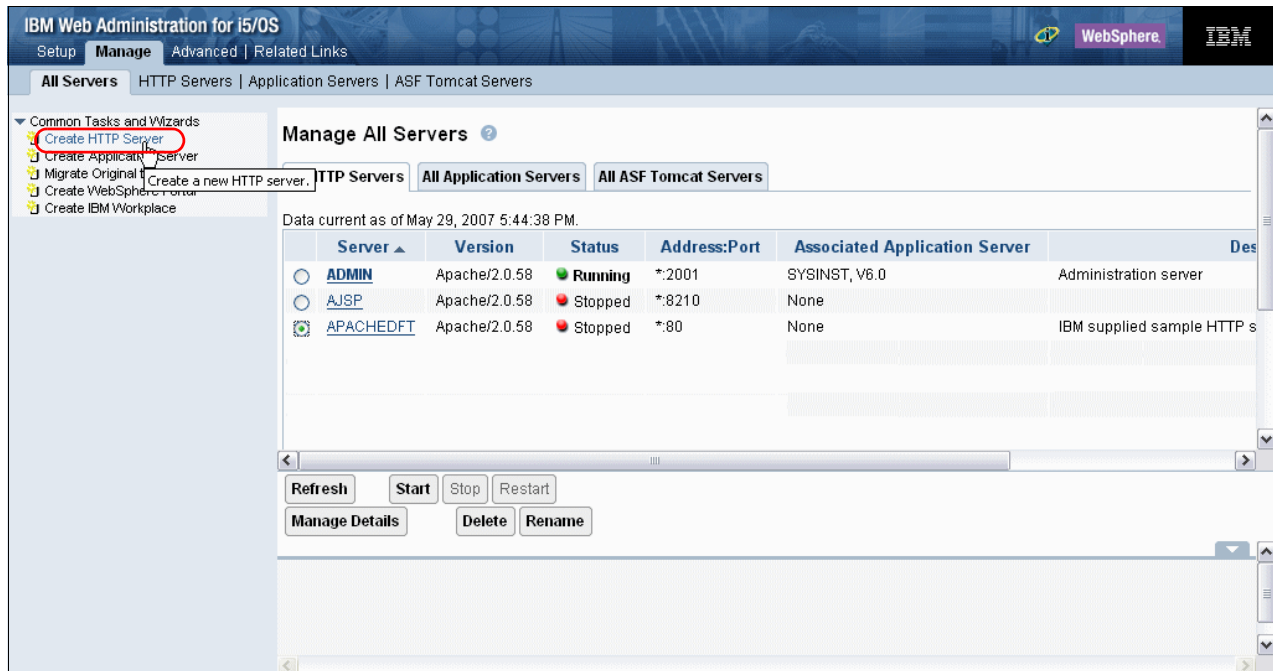

Figure 5-15 Create an HTTP Server option in the IBM Web Administration for i5/OS

4. In the next window (Figure 5-16), type the name of your new HTTP server, **REMOTEHTTP**, and a description. Click **Next**.

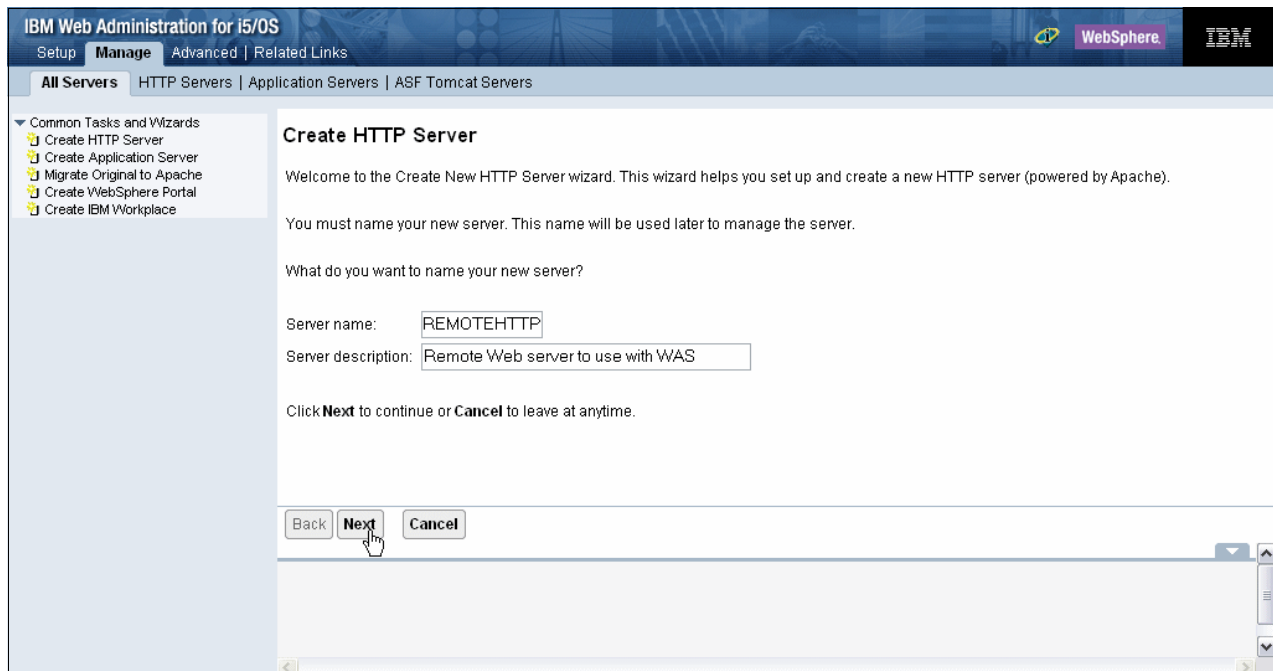

Figure 5-16 Enter the name of the Web server

5. Click **Next** to accept the default value for the server root.
6. Click **Next** to accept the default value for the document root.

7. In the next window (Figure 5-17), choose **All IP addresses** from the IP Address menu, and enter the port number for your HTTP server. We chose port **80**. Click **Next**.

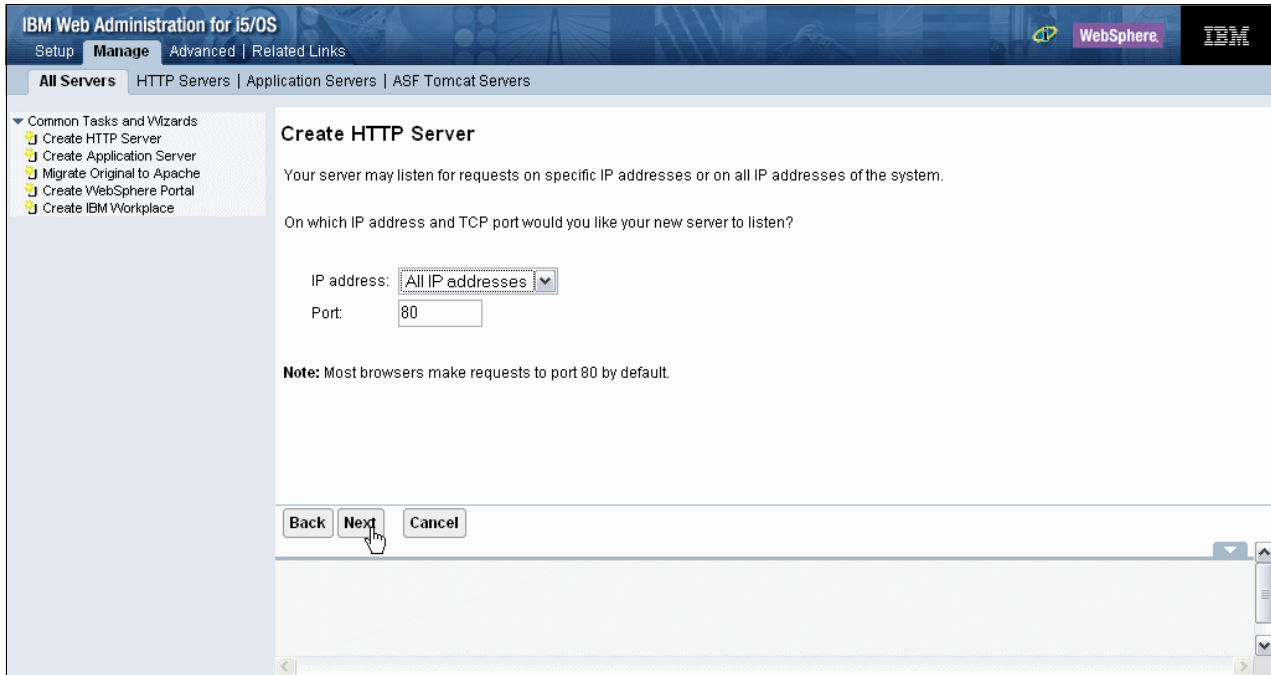

Figure 5-17 Choose port for the Web server, and select to listen on all IPs for requests

8. Click **Next** to accept the default value for the access log.
9. Click **Next** to accept the default value for the time to keep the log file.
10. Figure 5-18 is the summary page. Review the configuration values, and click **Finish**.

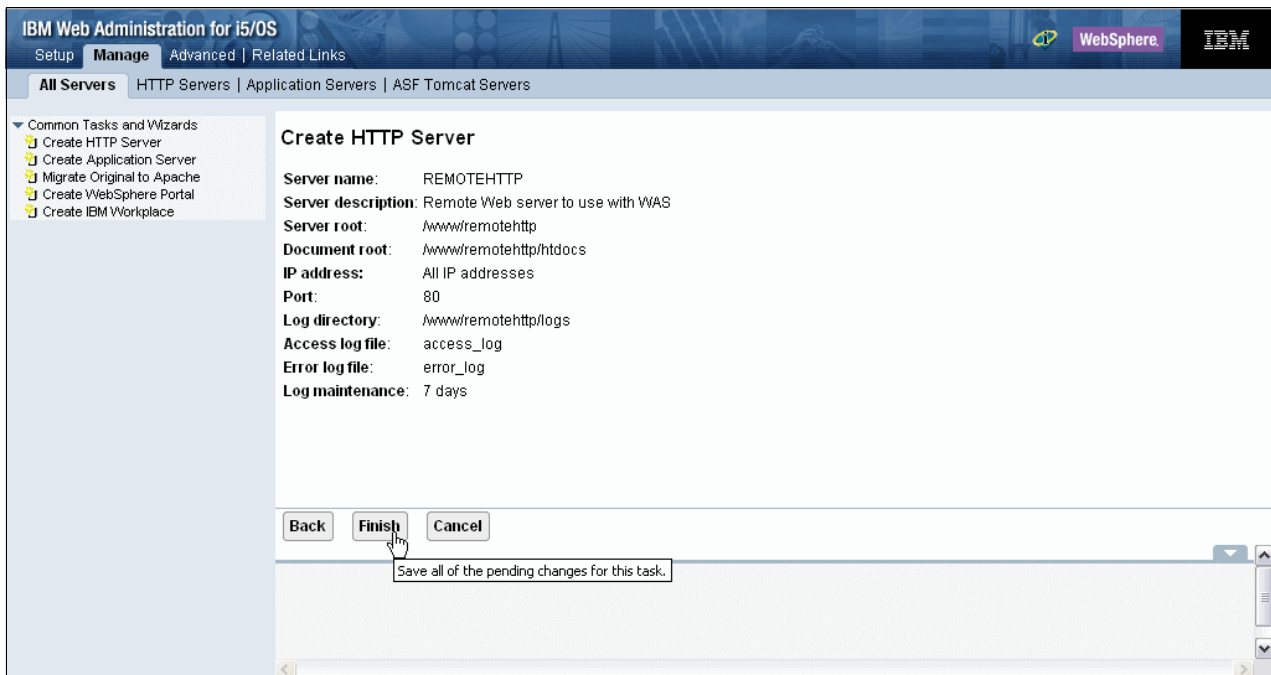

Figure 5-18 Summary window for Create HTTP Server

The IBM HTTP Server for i5/OS instance is created and the Welcome page for the new server opens.

At this stage we have a Web server instance that is ready to accept requests, but there is no relationship or link between the Web server instance and the WebSphere profile on the application server machine (Machine A in Figure 5-7 on page 172).

### 5.3.3 Creating a non-default HTTP server profile

To properly configure an association between a WebSphere profile and an HTTP Server instance, you need to create a special type of the WebSphere profile, called `http`. This profile does not provide a full set of WebSphere functions, so you cannot run it. The only purpose of this profile is to support the remote Web server configuration.

Use the `manageprofiles` script in the `<plugin_install_root>/bin` directory, on the Web server system for this purpose. By default this script is located in:

```
/QIBM/ProdData/WebSphere/Plugins/V61/webserver/bin
```

The command is `manageprofiles -create -profileName <Web_server_instance_name> -templatePath http`.

Choosing the same WebSphere profile name as the HTTP Server instance name makes it easier to know what WebSphere profile is associated with a specific HTTP Server instance.

In our case, we used the `manageprofiles` script to create a WebSphere profile called `REMOTEHTTP`, which matches the Web server instance name.

### 5.3.4 Associating the Web server instance and Web server profile

We can now create an association between the HTTP server instance and the newly-created WebSphere profile `REMOTEHTTP`. If you followed the guidance in 5.3.3, “Creating a non-default HTTP server profile” on page 180, substitute the name of the WebSphere profile that you created. To make the association, performing the following steps, which are also illustrated in Figure 5-19 on page 181:

1. Access IBM Web Administration for i5/OS, and select **Manage** → **HTTP Servers**.
2. Select the relevant HTTP server from the Server menu, in our case it is **REMOTEHTTP**.
3. Click **WebSphere Application Server**, which is located at the bottom of the navigation pane.
4. From the pull-down menu, select the Web server profile that you created. In our case, the Web server profile is **REMOTEHTTP**.
5. Click **OK** to save changes and to make the association.

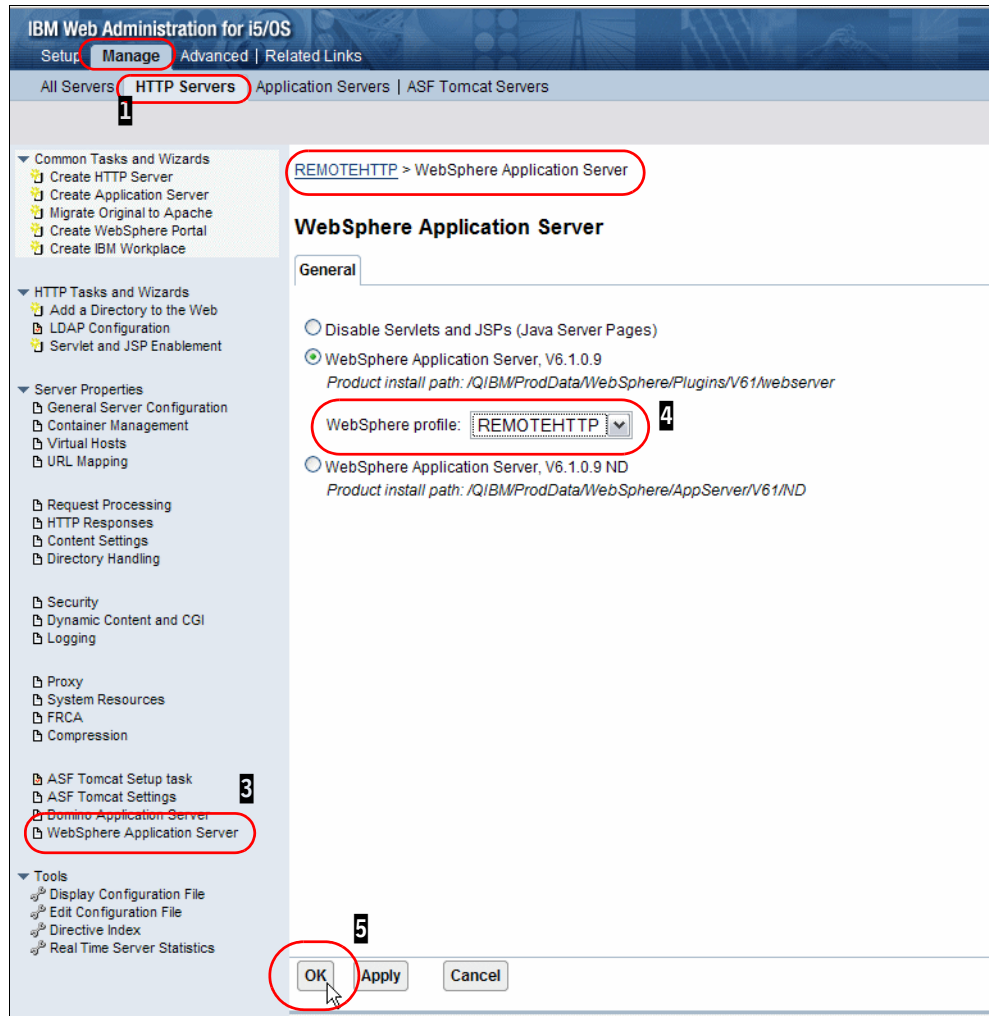

Figure 5-19 Associating the HTTP Server instance and profile

### 5.3.5 Creating a Web server definition in the WebSphere profile

In the previous section, where you associated the remote HTTP server instance with your WebSphere profile, IBM Web Administration for i5/OS created a script file called “under the covers”. This script file contains commands for updating the WebSphere Application Server profile on the application server (Machine A in Figure 5-7 on page 172) and for creating a Web server definition in the WebSphere Application Server repository.

The next stage is to run the “under the covers” script on the WebSphere Application Server system. You must copy this file from its current location to the `/bin` directory of your WebSphere Application Server profile on the application server before you execute it. Use the following steps to update the WebSphere Application Server configuration on the application server system:

1. Map a network drive to the `/root` share of the remote Web server system. Alternatively, you can use iSeries Navigator to copy this file.
2. Map a network drive to the `/root` share of the WebSphere Application Server system.
3. Copy the following file from the Web server system:

```
/QIBM/UserData/WebSphere/Plugins/V61/webserver/profiles/<HTTP_profile_name>/config/IHS_<HTTP_instance_name>/configureIHS_<HTTP_instance_name>
```

Copy the file previously mentioned to the WebSphere Application Server system in the following location, where:

- <HTTP\_profile\_name> is the name of the WebSphere profile that you created in 5.3.3, “Creating a non-default HTTP server profile” on page 180.
- <HTTP\_instance\_name> is the name of your HTTP Server instance that you created in 5.3.2, “Creating an instance of IBM HTTP Server for i5/OS” on page 177.
- <WAS\_profile\_name> is the name of the WebSphere profile on the application server machine (Machine A in Figure 5-7 on page 172).

```
/QIBM/UserData/WebSphere/AppServer/V6.1/Base/profiles/<WAS_profile_name>/bin/
```

4. On the application server system, start a Qshell session with the STRQSH command.

5. Run the following command:

```
cd
/QIBM/UserData/WebSphere/AppServer/V6.1/Base/profiles/<WAS_profile_name>/bin/
```

6. On the application server, check the status of your profile:

```
serverStatus -all -profileName <WAS_profile_name>
```

If your server status is STOPPED, start your profile:

```
startServer -profileName <WAS_profile_name>
```

7. On the application server, run the script:

```
configureIHS_<HTTP_instance_name>
```

8. After the script completes, connect to your application server profile’s administrative console at:

```
http://<WAS_hostname>:<admin_port>/ibm/console
```

9. Expand **Servers** in the navigation pane, and click **Web servers**. You should see your remote Web server instance in the list (see Figure 5-20 on page 183).

### 5.3.6 Propagating the plug-in configuration file to the Web server

Your Web server plug-in configuration file is generated by the WebSphere profile. After this file generates, copy it from the application server machine (Machine A in Figure 5-7 on page 172) to the Web server machine (Machine B in Figure 5-7 on page 172), which you can achieve in one of the several ways:

- ▶ If your Web server is an unmanaged node that is running IBM HTTP Server, WebSphere Application Server supports remote administration of that node, similar to how it is done for the managed node. In this case, you can use the WebSphere Administrative Console to propagate the plug-in configuration file.
- ▶ If your Web server is an unmanaged node, then copy the plug-in configuration file manually. Put the file in the location that is specified in the HTTP Server instance configuration (see the first line in the HTTP Server configuration file, similar to Figure 5-4 on page 169). If you followed our instructions, the file should be copied to:

```
/QIBM/UserData/WebSphere/Plugins/V61/webserver/profiles/<HTTP_profile_name>/config/IHS_<HTTP_instance_name>/
```

- ▶ If your Web server is a managed node, you can use the WebSphere Administrative Console to propagate the plug-in configuration file.

To propagate the plug-in configuration file to the remote Web server:

1. Login to the WebSphere Administrative Console on the application server.
2. If you have not previously configured the user ID and password for managing IBM HTTP Server, do so now by referring to 5.7.1, “Preparing the Web server for remote management” on page 194. If you have a firewall between the Web server and application server machines, make sure to open port 2001 (IBM Web Administration for i5/OS port).
3. If your HTTP Server instance listens on a port other than 80, you need to add that port to the alias table in the virtual host configuration. For the instructions, see 8.3.6, “Creating a virtual host alias for the remote Web server” on page 256.
4. Expand **Server** → **Web servers**.
5. Select the check box next to the name of your Web server (**IHS\_REMOTEHTTP** in our case), and click **Generate Plug-in**, as shown in Figure 5-20.

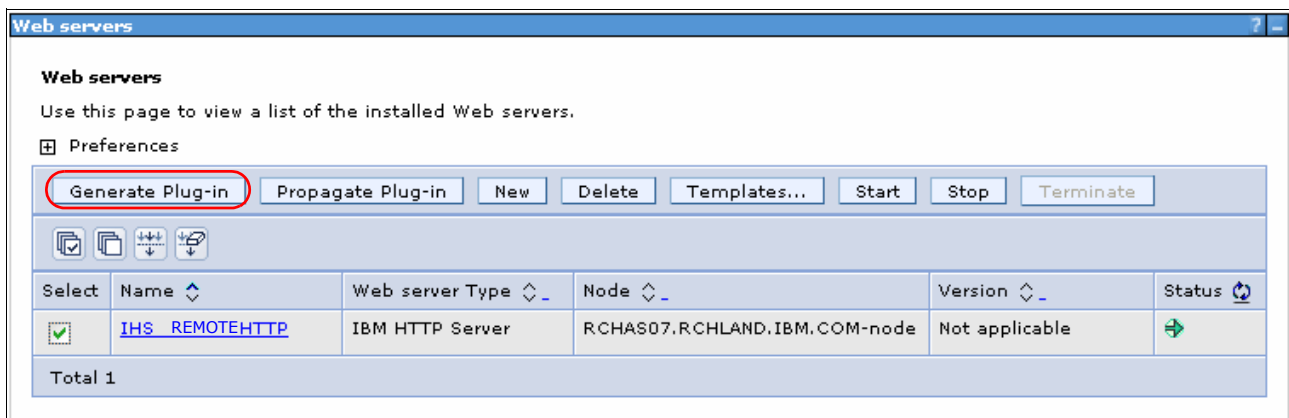

Figure 5-20 Generating a Web server plug-in configuration file

A plug-in generation success message is displayed in the WebSphere administrative console, as shown in Figure 5-21.

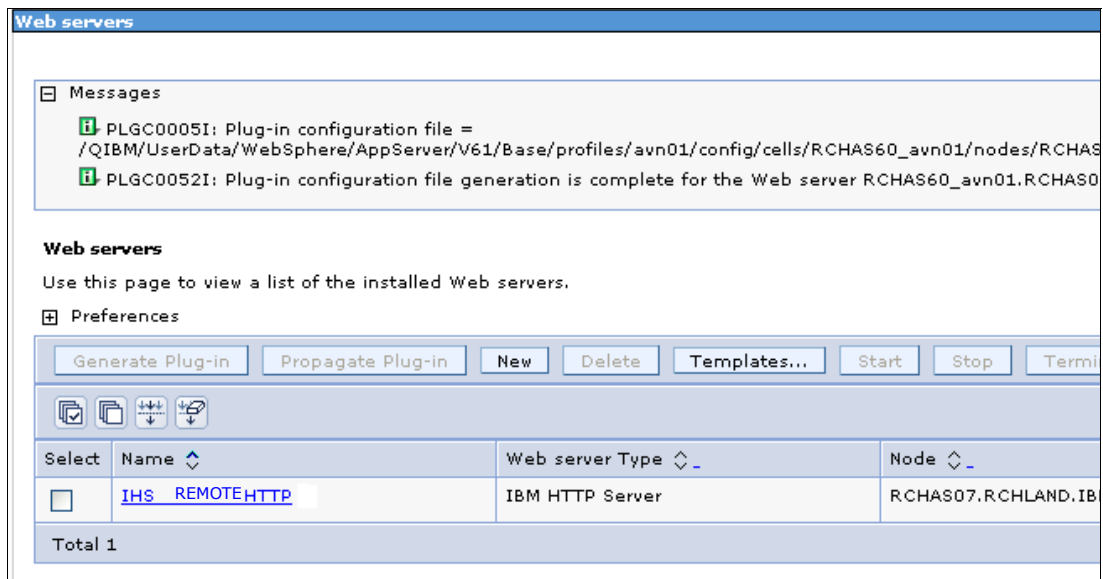

Figure 5-21 Plug-in regeneration complete

6. Select the check box next to the name of your Web server (**IHS\_REMOTEHTTP** in our case), and click **Propagate Plug-in**, as shown in Figure 5-22.

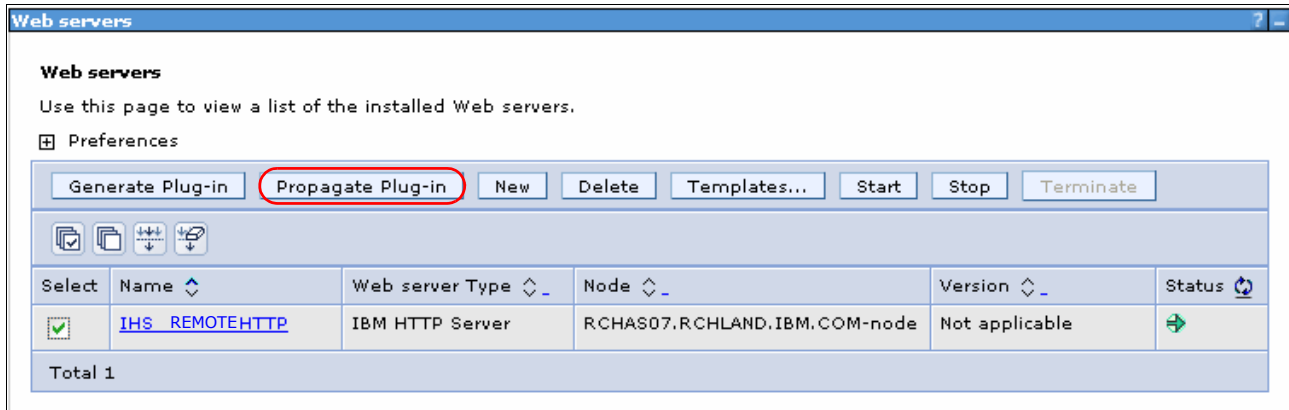

Figure 5-22 Propagating the plug-in configuration file to the Web server

A plug-in propagation success message is displayed in the WebSphere administrative console, as shown in Figure 5-23.

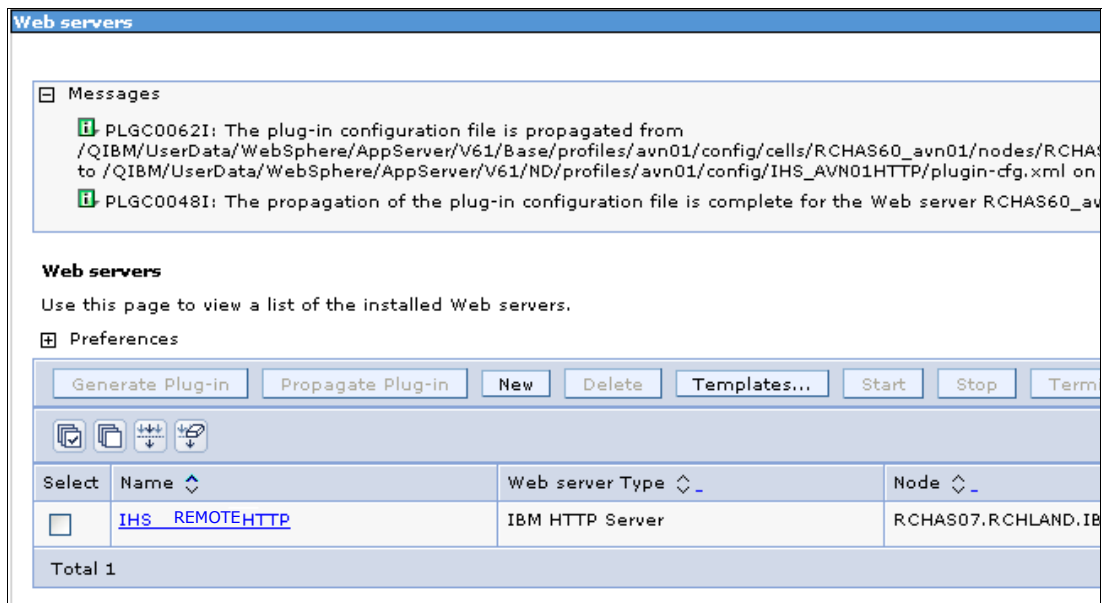

Figure 5-23 Plug-in propagation to Web server complete

Next, you must restart the Web server instance to pick up the new plug-in configuration file.

7. Login to IBM Web Administration for i5/OS on your HTTP server system (Machine B in Figure 5-7 on page 172).
8. Select **Manage** → **HTTP Servers** sub-tab.
9. Select your HTTP server name from the Server list (see Figure 5-24 on page 185).
10. If your HTTP server instance is running, restart it by clicking the **Restart** button, as shown in Figure 5-24 on page 185. If it is not running, start it now by clicking the **Start** button.

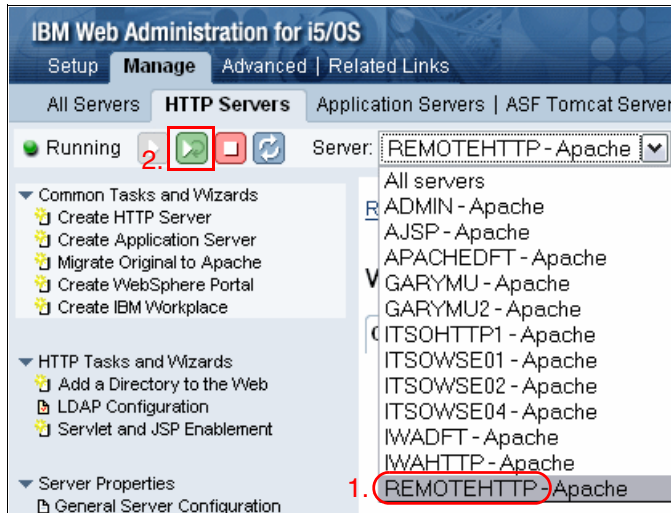

Figure 5-24 Restart the Web server instance

In addition, you can rely on the WebSphere profile to automatically regenerate and propagate the Web server plug-in configuration file every time you make any changes in the WebSphere profile configuration. This feature is applicable for a scenario where you can manage a Web server from the WebSphere Administrative Console (see information at the beginning of this section). It is enabled by default in the Plug-in properties panel for your Web server definition (see Figure 5-25).

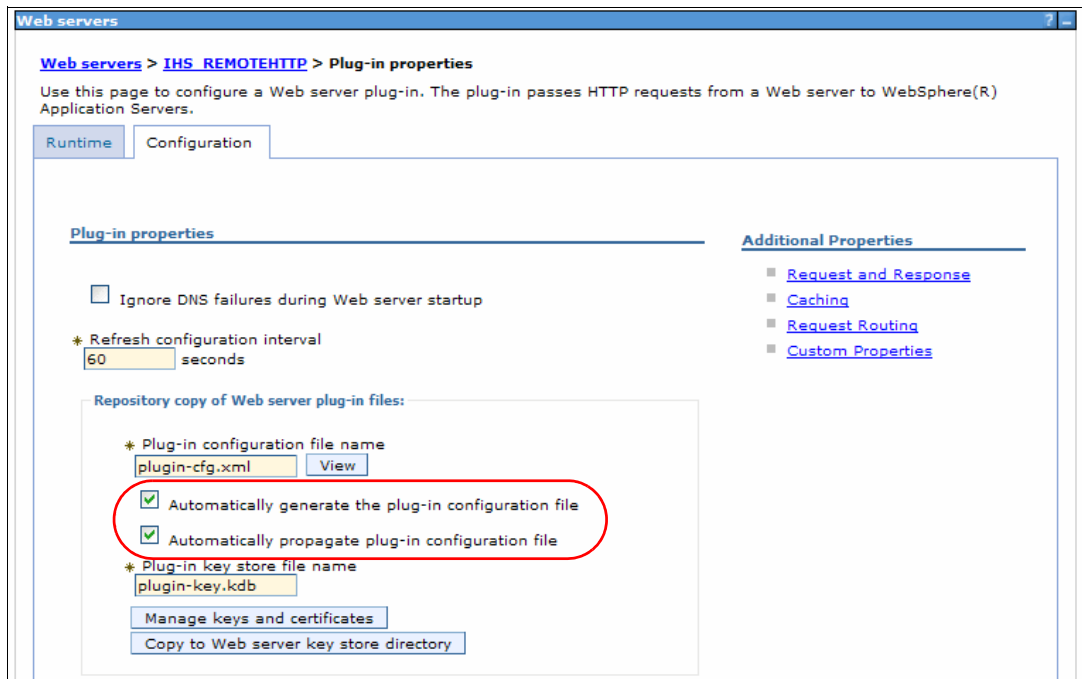

Figure 5-25 Automatic plug-in configuration file management

In this section, we showed you how to configure WebSphere Application Server to use a remote Web server on an unmanaged node. Such a configuration is typically employed where the Web server and application server are separated by a firewall. Now, all that remains is to test the configuration, as described in the next section.

## 5.4 Verifying the Web server configuration

Whether the Web server is local or remote to the application server, you can verify that the configuration is correct by accessing the Snoop servlet. To access the Snoop servlet:\

Type the following URL in a Web browser, assuming that the Web server is configured to listen on the standard HTTP port of 80:

`http://<Web_server_hostname>/snoop`

You should see the Snoop servlet displayed as shown in Figure 5-26. If you get an error, there may be a problem with the Web server configuration. Verify that you followed the configuration steps correctly. You may also want to consult *WebSphere Application Server V6: Web Server Plug-in Problem Determination*, REDP-4045.



**Snoop Servlet - Request/Client Information**

**Requested URL:**

`http://rchas .rchland.ibm.com/snoop`

**Servlet Name:**

Snoop Servlet

**Request Information:**

Request method	GET
Request URI	/snoop
Request protocol	HTTP/1.1
Servlet path	/snoop

Figure 5-26 Using the Snoop servlet to verify Web server configuration

## 5.5 Configuring additional Web server definitions

WebSphere Application Server allows you to configure more than one Web server to work with an application server profile. This capability is present in WebSphere Application Server Base and WebSphere Application Server Network Deployment editions. The Express edition allows you to associate only one Web server instance with each application server profile.

Adding additional Web servers to the WebSphere environment is identical to one of two scenarios, which we described in this chapter:

- ▶ For local Web server scenario, see 5.2, “Configuring a local Web server with WebSphere Application Server” on page 167.
- ▶ For remote Web server scenario, see 5.3, “Configuring a remote Web server with WebSphere Application Server” on page 171.

At the end, you should have more than one entry in the Web servers panel of the, as shown in Figure 5-27.

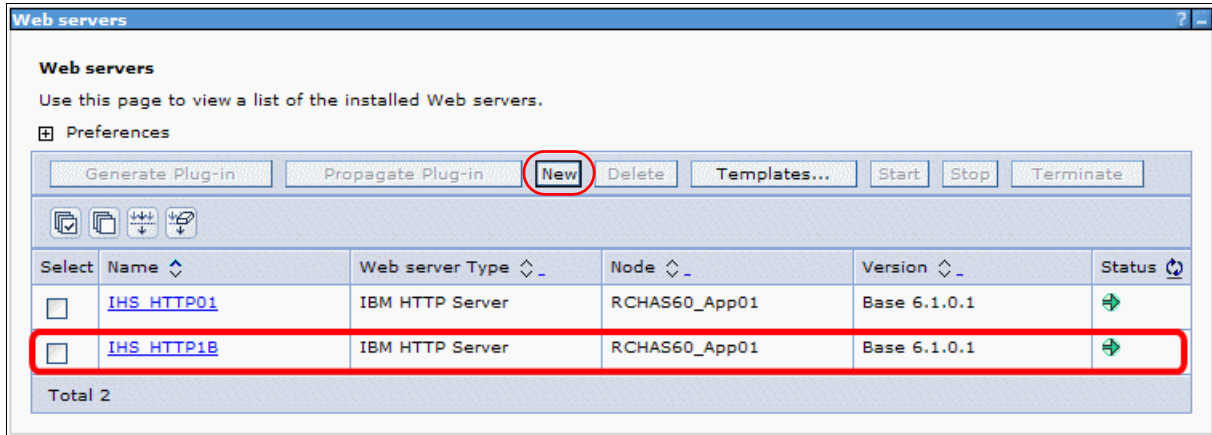

Figure 5-27 WebSphere administrative console - Web server definitions

Additionally, the WebSphere Administrative Console provides a wizard for manually adding a new Web server definition. You can invoke this wizard by clicking the **New** button, as shown in Figure 5-27. However, using IBM Web Administration for i5/OS to either directly create a definition or generate a script file is an easier way to add a new Web server definition, and we recommend using IBM Web Administration for i5/OS.

## 5.6 Adding a Web server definition to a cell profile

In this section, we focus on the association between Web servers and application servers that are federated into a cell profile. This next example is based on the cell profile we created in 4.2.9, “Creating an application server cell” on page 134. See that chapter for instructions on creating the initial environment that we used in this section.

Complete the following steps to configure Web servers:

1. Open the WebSphere Deployment Manager Administrative Console. See “Accessing the WebSphere Administrative Console directly” on page 121 to learn how to open the deployment manager administrative console.
2. Select **System administration** → **Cell** → **Local Topology** tab.

Figure 5-28 on page 188 shows the cell topology that represents our example topology that we created in 4.2.9, “Creating an application server cell” on page 134.

You can see there are two application servers: MyAppSvr01 and MyAppSvr02. Currently there are no HTTP servers assigned to these application server profiles.

There is also the DefaultApplication application, which is installed on both application servers in the cell.

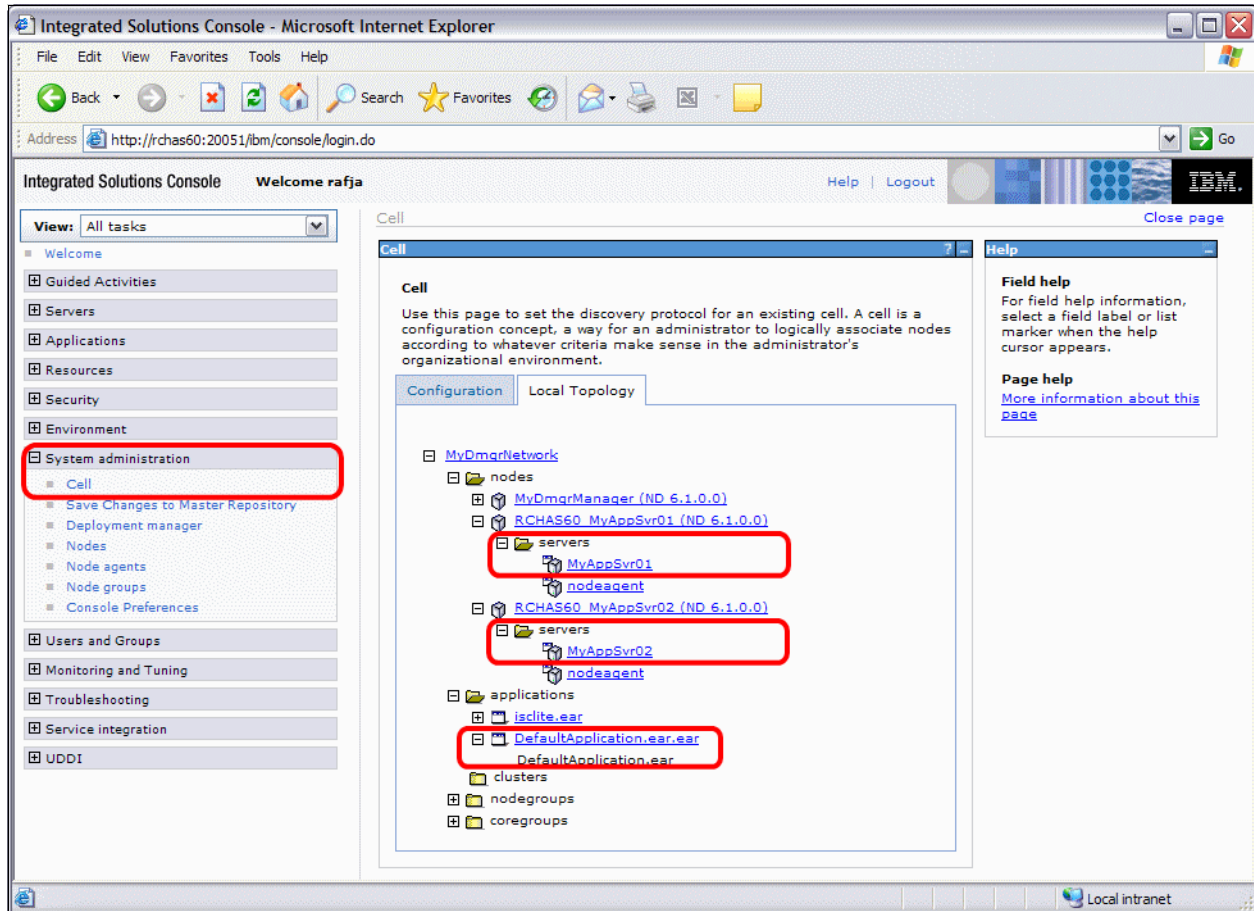

Figure 5-28 WebSphere administrative console - Local topology

- Open IBM Web Administration for i5/OS and click the HTTP server instance that you want to associate. In the example, the HTTP server instance name is **HTTP01**, and it is located on the same machine (partition) as the associated WebSphere profile.

**Note:** See 4.2.1, “Starting IBM Web Administration for i5/OS” on page 89 for information about how to start IBM Web Administration for i5/OS.

- Click the **WebSphere Application Server** link, as shown in Figure 5-3 on page 168. Under the **General** tab of the WebSphere Application Server window, you can see a list of application server products that are installed.
- Select WebSphere Application Server, V6.1 ND, and choose the application server profile that you want associated with the HTTP server instance. In this example, the WebSphere Application Server profile name is **MyAppSvr01**.
- There are two more menus present that allow you to map all applications to the new HTTP server instance and to start the application server profile together with this HTTP server instance.

Select **All applications** to be mapped, leave the next drop-down menu set to **No**, and click **OK**. The wizard configures the Web server configuration files and creates a Web server definition object in the WebSphere Application Server profile configuration.

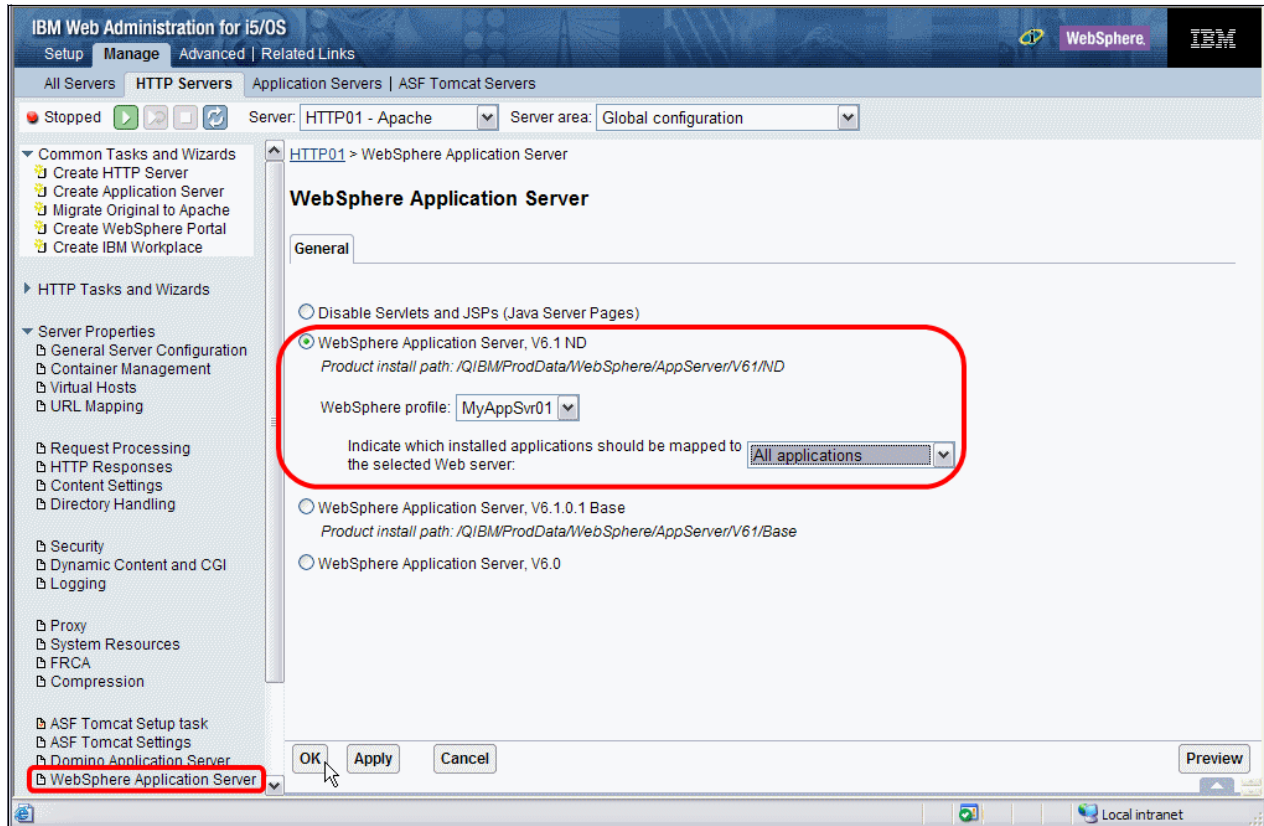

Figure 5-29 IBM Web Administration for i5/OS - WebSphere Application Server

- Open IBM Web Administration for i5/OS on the system where you run the second WebSphere profile (MyAppSvr02 in our example). Click the HTTP server instance you want to associate with the WebSphere profile. Following the previous steps, associate HTTP server name **HTTP02** with the second application server federated into the cell **MyAppSvr02**.

Figure 5-30 on page 190 represents the association between the second HTTP server and the application server profile.

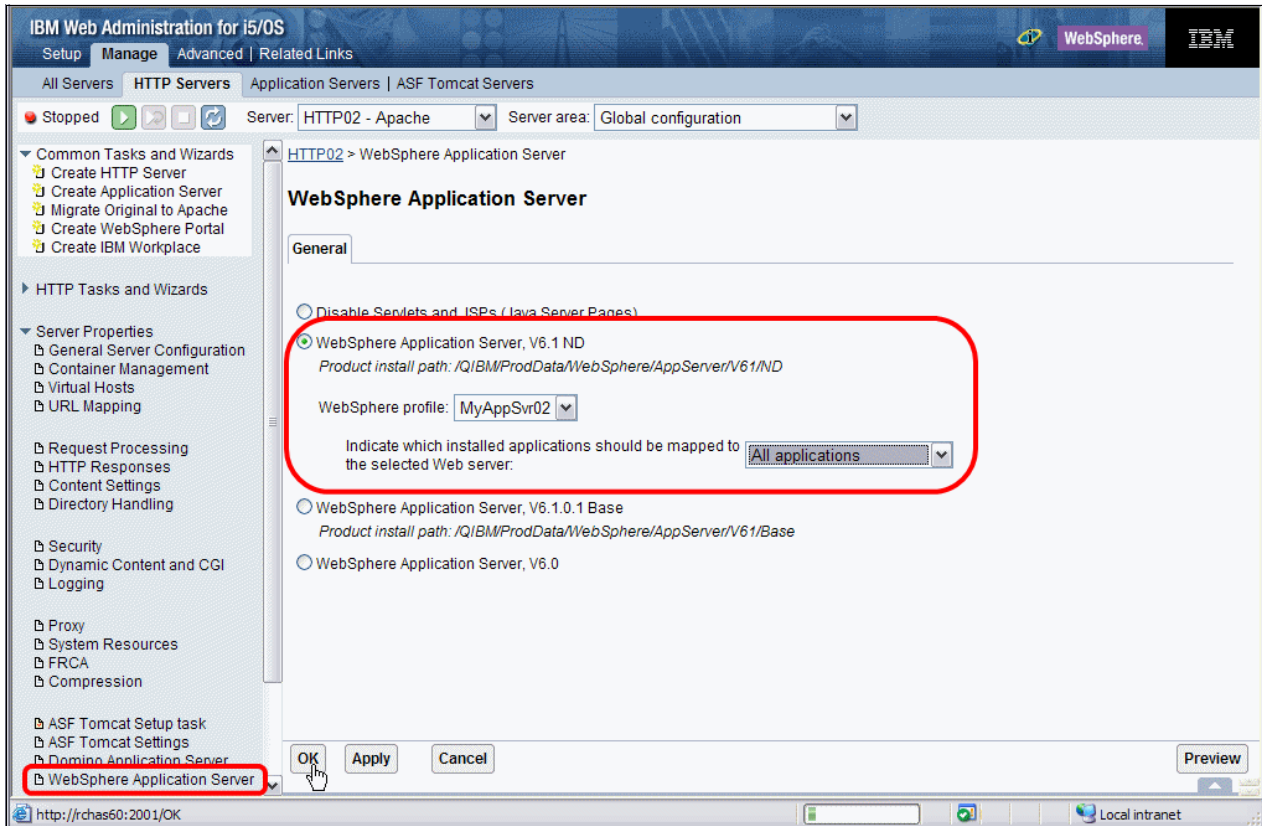

Figure 5-30 IBM Web Administration for i5/OS - WebSphere Application Server

As a result of both associations, the WebSphere Deployment Manager configuration was updated with the new Web server definition objects (Figure 5-31 on page 191). Each of these two Web server definition object creates a pairing with an appropriate HTTP server instance.

The first Web server definition entry with the name **IHS\_HTTP01** represents the **HTTP01** Web server instance. The second entry with the name **IHS\_HTTP02** represents the **HTTP02** Web server instance.

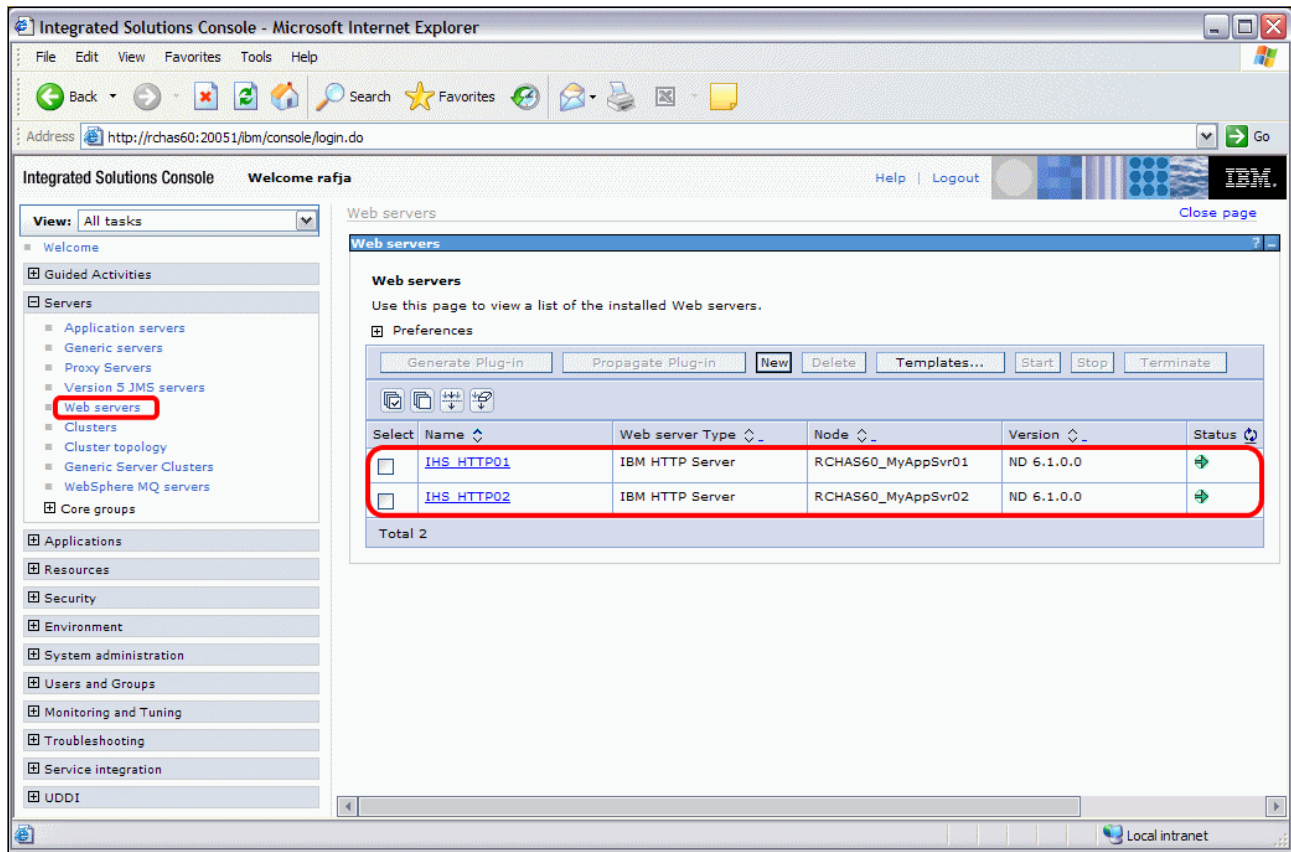

Figure 5-31 WebSphere administrative console - Web servers

- One of the differences when you make an association between the Web server and the Deployment Manager profile is that in the Deployment Manager you have to update virtual host aliases manually.

In our example, the Web server instances listen on ports 90 and 91. Create a virtual host alias for both of these ports under the default\_host virtual host, as shown in Figure 5-32 on page 192.

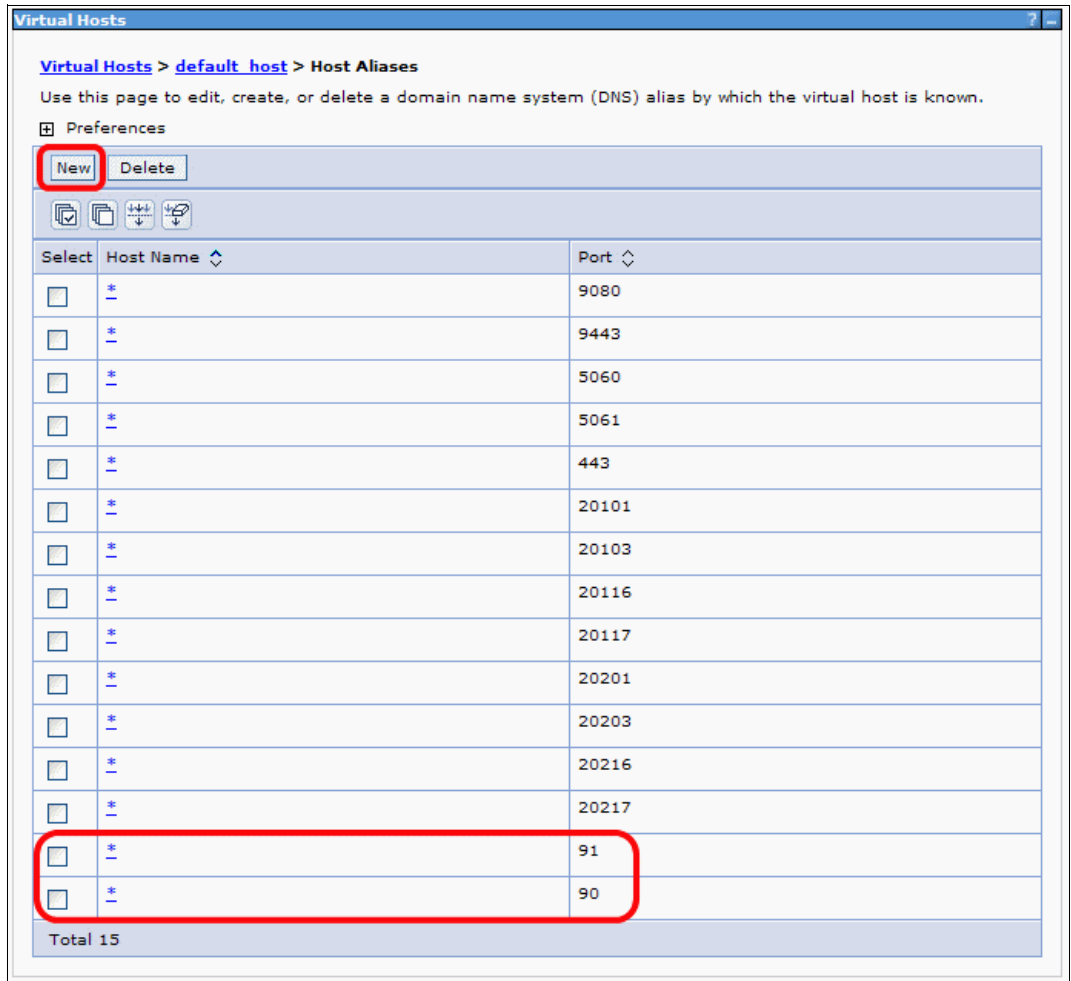

Figure 5-32 WebSphere administrative console - Virtual hosts

- Changes to virtual hosts require you to restart application servers. In the cell architecture, you can restart servers from the Deployment Manager console. Expand **Servers**, and click **Application Servers**. Select the check boxes next to the server names, and click **Stop**. When the servers are stopped, select the check boxes again, and click **Start**, as shown in Figure 5-33 on page 193.

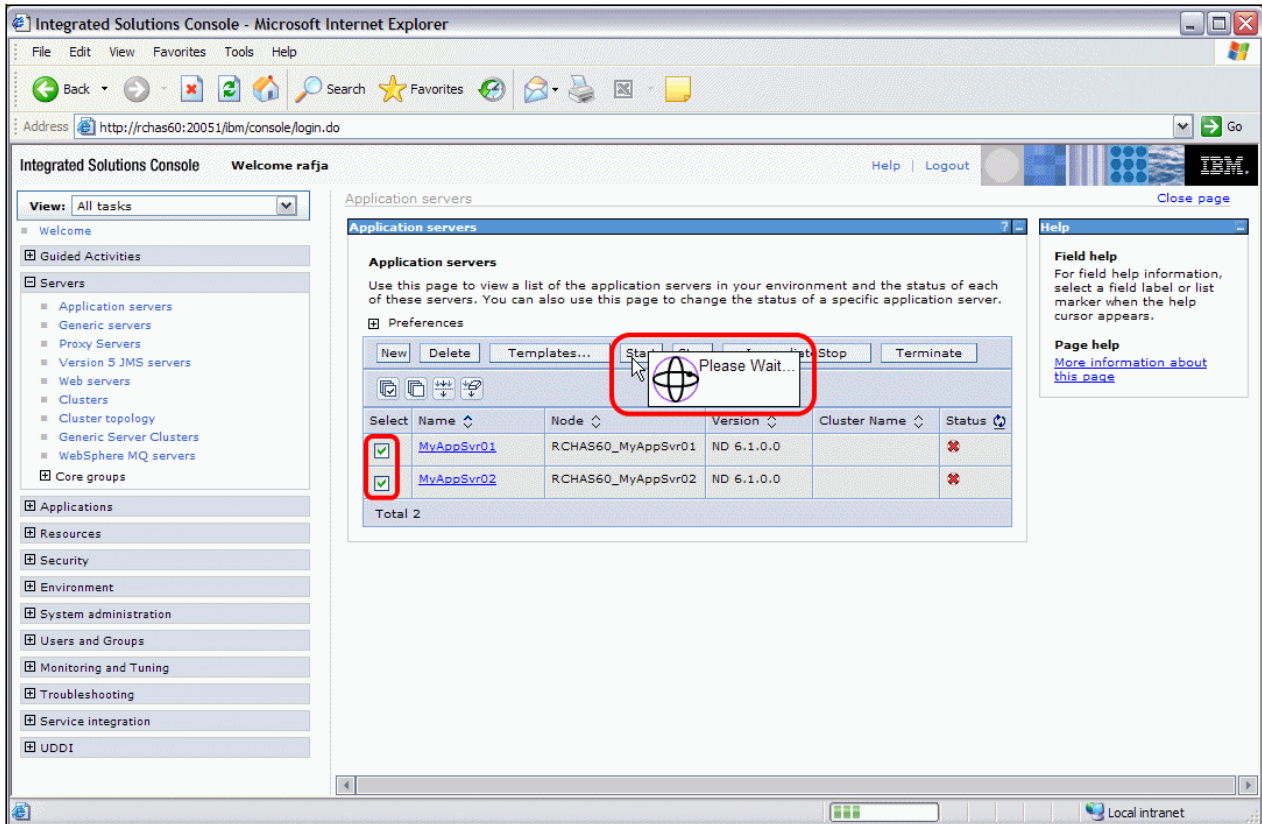

Figure 5-33 WebSphere administrative console - Application servers restart

Figure 5-34 shows the updated cell topology after HTTP servers were associated with the application server profiles.

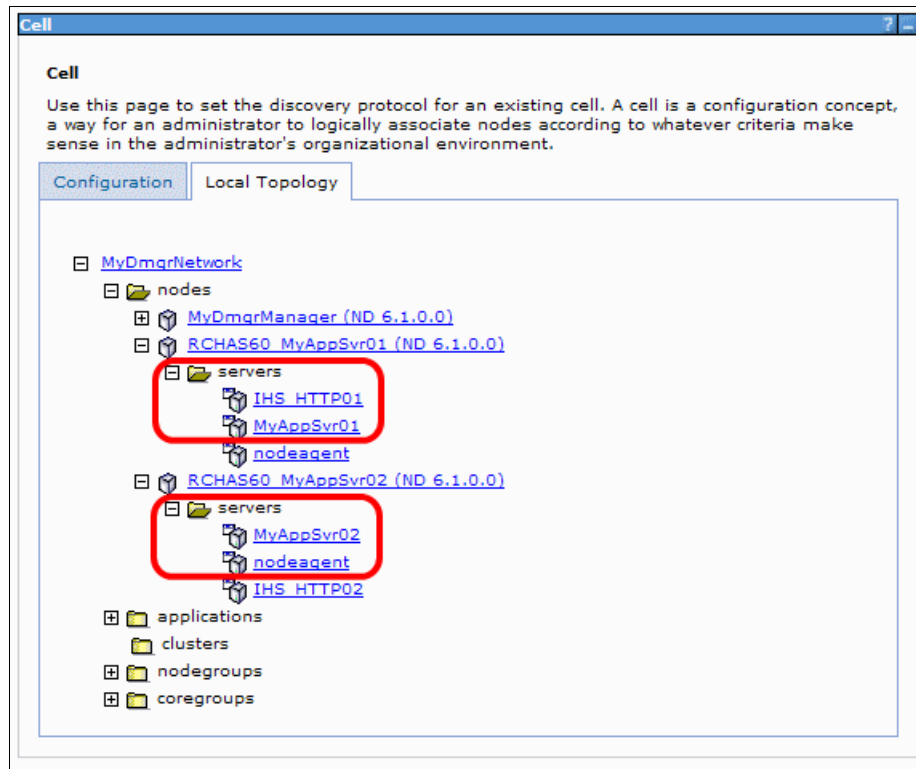

Figure 5-34 WebSphere administrative console - Local topology

As a final step to ensure that your cell with associated Web servers works fine, you can request the snoop servlet ([http://<host\\_name>:<port>/snoop](http://<host_name>:<port>/snoop)) from each of the Web servers. In our case, we would request the snoop servlet on ports 90 and 91 to test HTTP01 and HTTP02 respectively.

## 5.7 Managing IBM HTTP Server from the WebSphere Administrative Console

The WebSphere Application Server V6.1 Administrative Console enhances functions that are delivered in version five of the product. From the Web server perspective, there are new wizards that allow you to automate some of the tasks. You can also administer the Web server instance from within the WebSphere Administrative Console.

### 5.7.1 Preparing the Web server for remote management

In this topic, we outline how to set up the user name and password that are required for some of the remote Web server administration tasks. Complete the following steps to configure remote administration for a Web server:

1. For a stand alone WebSphere profile only, start the HTTP \*ADMIN instance on the machine (partition) where you run a Web server.

2. Open the WebSphere administrative console, and click the Web server definition object for the Web server instance you want to work with. Figure 5-5 on page 170 shows how to navigate to the Web server definition window.

After you click the Web server definition object, you see a window similar to Figure 5-35.

Click **Remote Web server management** to set up the user name and password.

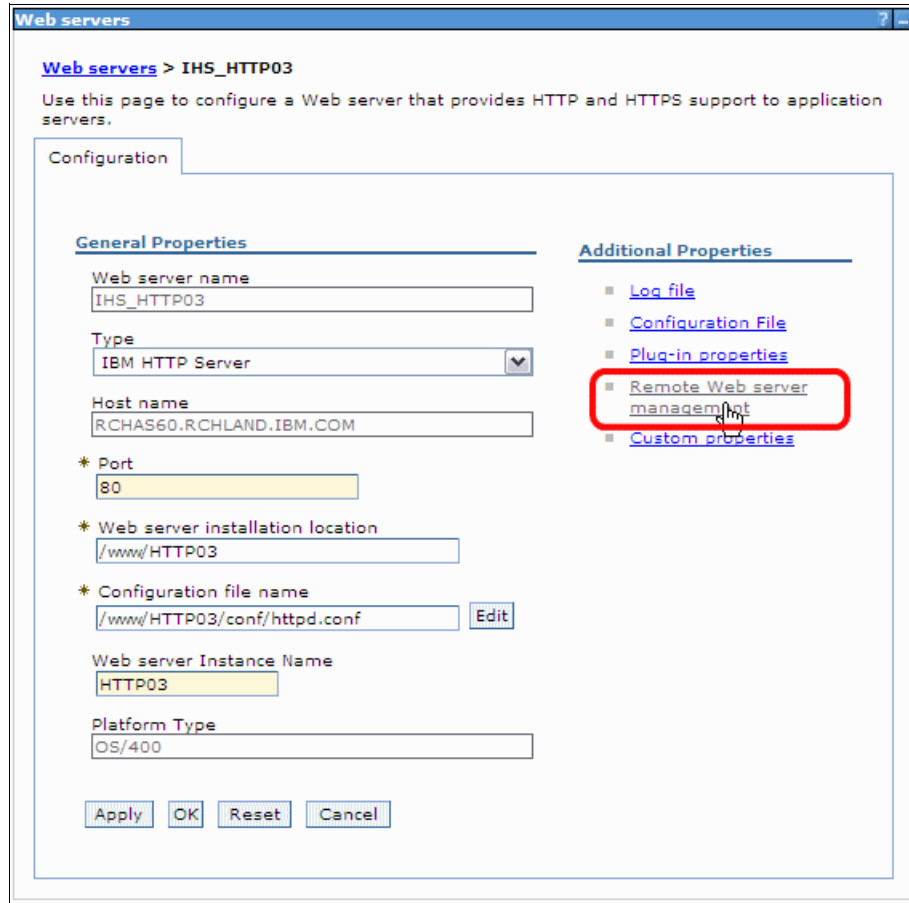

Figure 5-35 WebSphere Administrative Console - Web server configuration

The Configuration tab allows you to specify a username and password, which are now required to access the Web server instance resources (Figure 5-36 on page 196).

**Note:** To remotely manage Web servers in i5/OS, the specified i5/OS user profile must have \*ALLOBJ special authority.

3. Specify the username and password, and click **OK**.

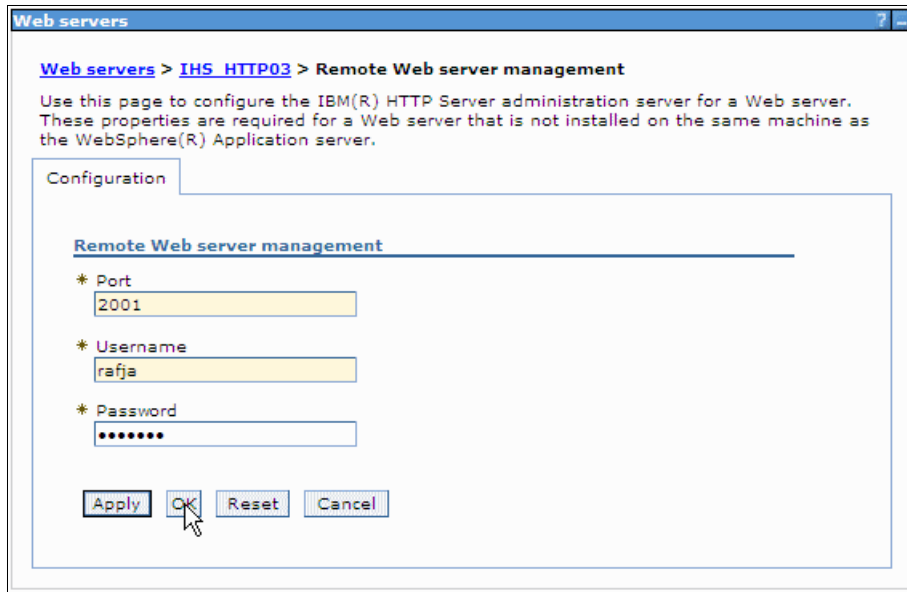

Figure 5-36 WebSphere Administrative Console - Remote Web server management

4. Save the changes to the master configuration, as shown in Figure 5-37.

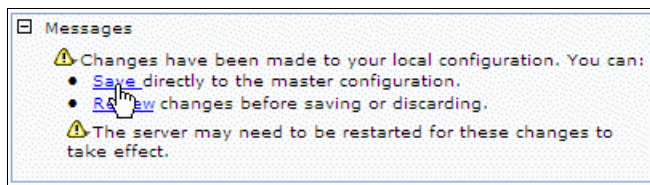

Figure 5-37 WebSphere Administrative Console - Save configuration changes

After you update the username and password parameters into the master configuration, any attempted access to the Web server resources is validated against these credentials.

## 5.7.2 Working with Web server configuration files from the WebSphere Administrative Console

In the previous sections, we showed you how to work with the Web server configuration file from IBM Web Administration for i5/OS. In this topic, we outline how to edit the Web server configuration from the WebSphere Administrative Console:

1. In the WebSphere Administrative Console, click the Web server definition object, which displays the window that we show in Figure 5-38 on page 197.
2. Click **Edit** to edit the Web server configuration file.

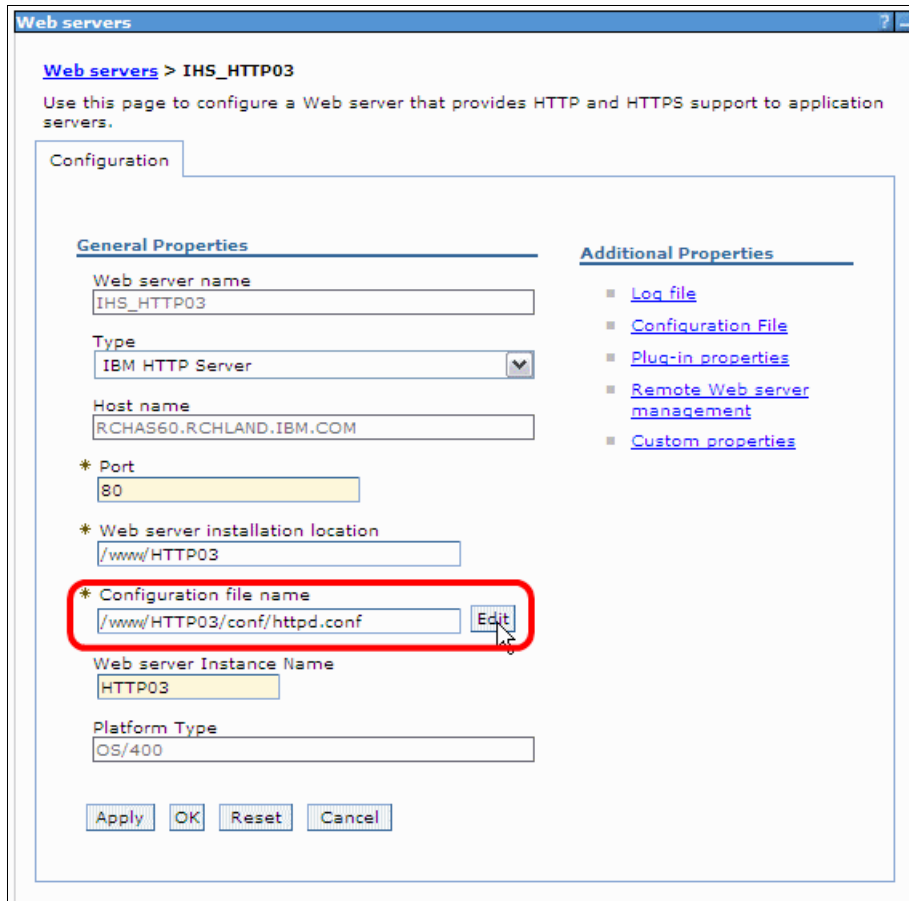

Figure 5-38 WebSphere Administrative Console - editing the Web server configuration file

Figure 5-39 on page 198 shows sample content of the Web server configuration file. By default, the file is located under the Web server instance directory.

**Attention:** Changes to the configuration file require you to restart the Web server instance.

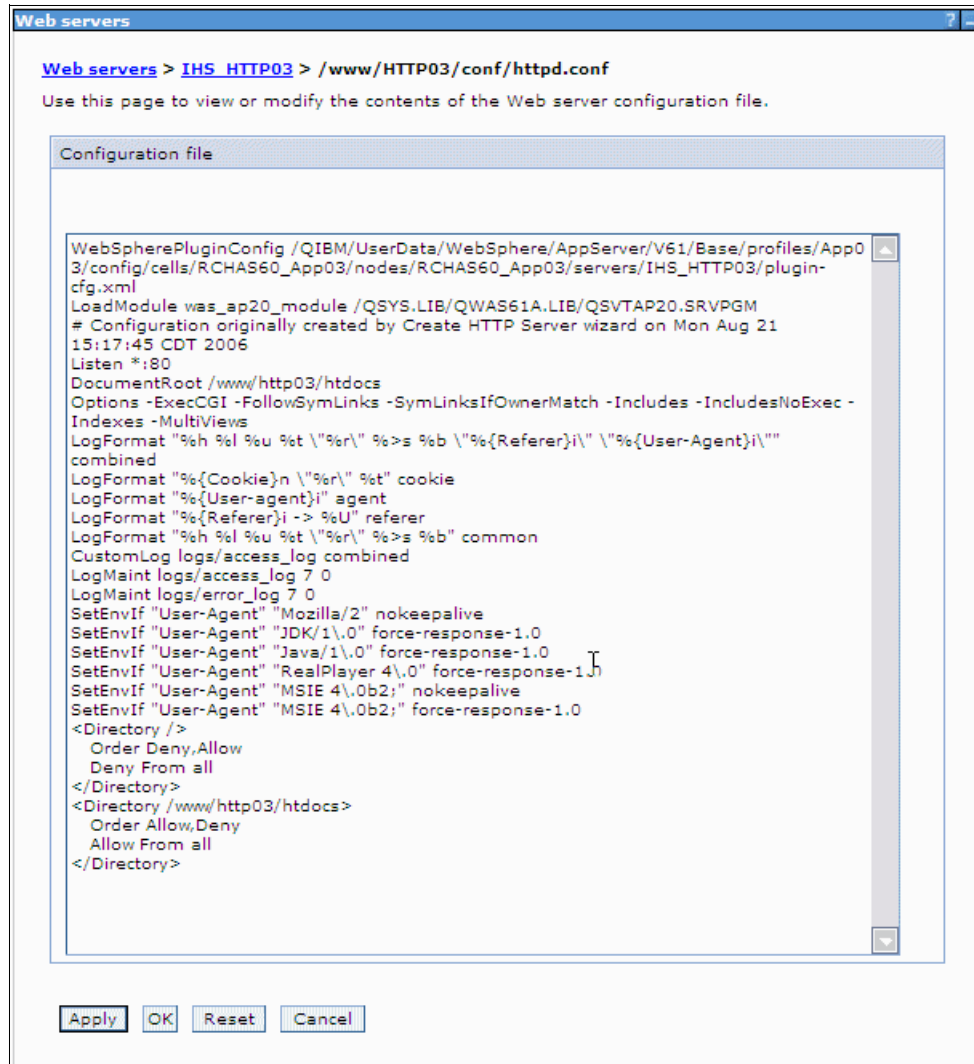

Figure 5-39 WebSphere administrative console - Web server configuration file

You could edit the Web server configuration file manually, for instance, to add parameters to allow the Web server to locate the plug-in module and configuration files. Click **Apply** or **OK** to save any configuration file changes.

### 5.7.3 Working with Web server log files

Working with the Web server log files is a day-to-day administration task. There are various ways to work with the log files. You can access them directly from the i5/OS command line, QShell, or IBM Web Administration for i5/OS. In this section, we demonstrate how to work with the HTTP server instance log files from the WebSphere Administrative Console.

1. Figure 5-40 shows the Web server definition configuration page. Click **Log file**.

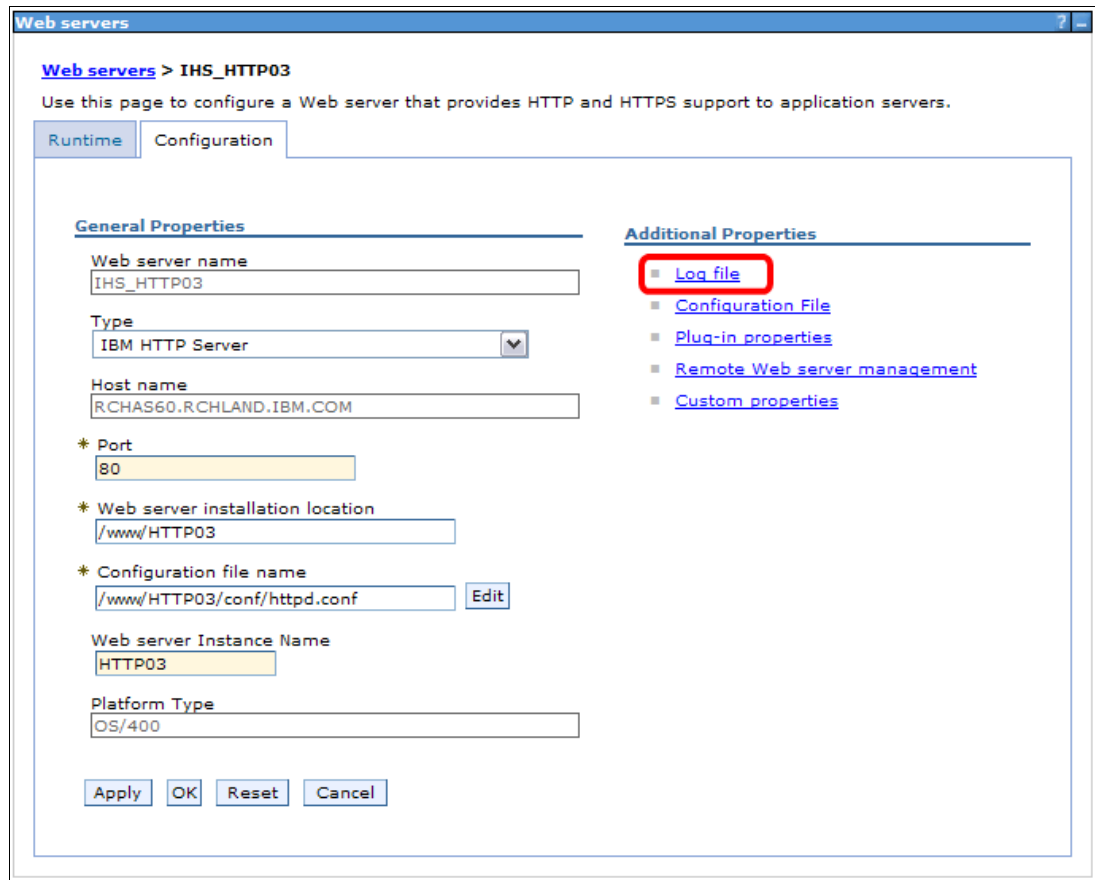

Figure 5-40 WebSphere Administrative Console - Web server login management

There are two tabs under the Log file window. On the **Configuration** tab (Figure 5-41), you can set up the location of the Web server log file. There are input fields on the window that correspond to the access log file name and the error log file name.

2. Click **Apply** or **OK** to confirm any changes to these parameters.



Figure 5-41 WebSphere Administrative Console - Web server log files configuration

3. Figure 5-42 shows the **Runtime** tab of the Log file window. Click one of the **View** buttons to open the access log or the error log file.

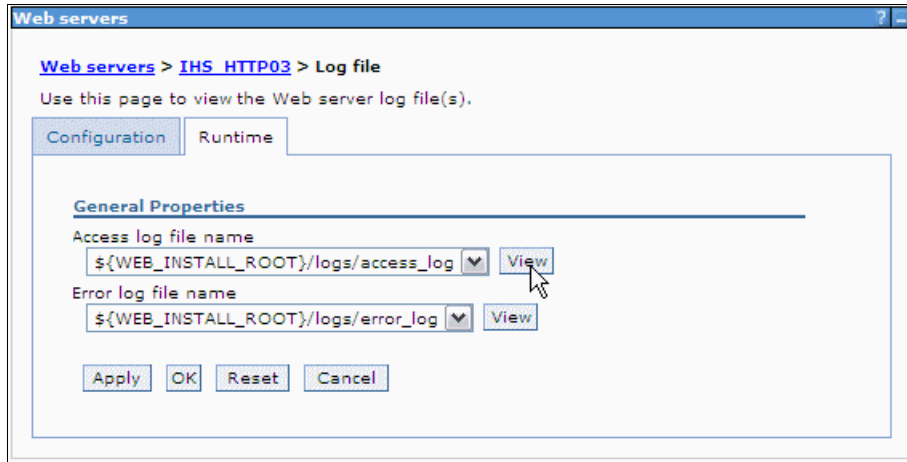

Figure 5-42 WebSphere administrative console - Web server log

Figure 5-43 shows an example of the Web server access log file contents.

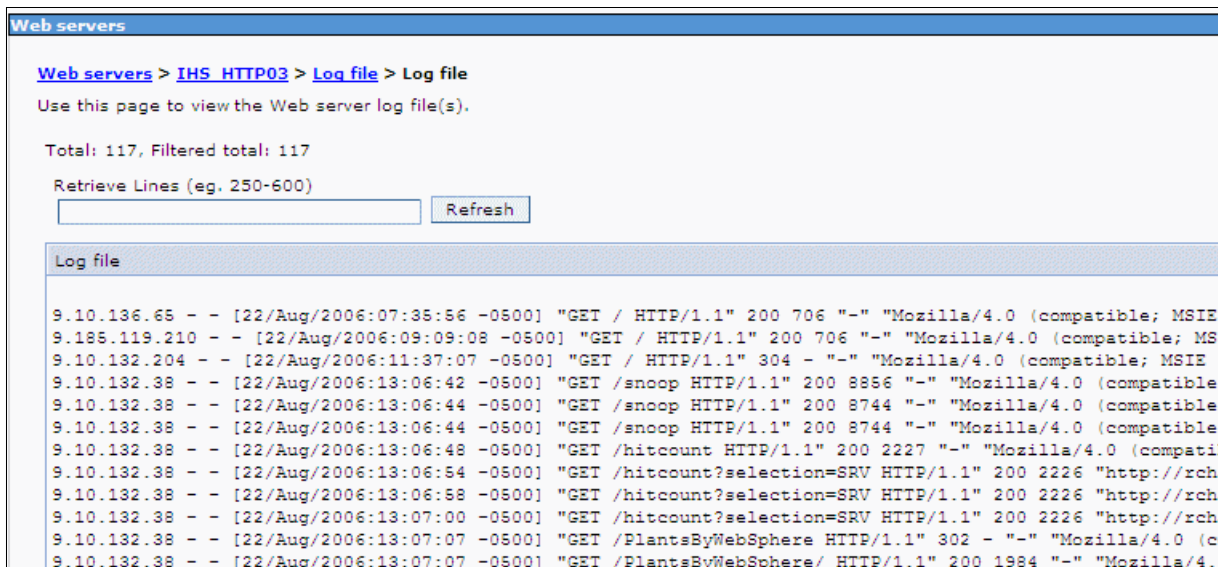

Figure 5-43 WebSphere administrative console - Sample Web server access log file

4. It is important to note that the size of the log file can grow significantly. In such cases, the administrative console by default shows you only a subset of the log. Specify the **Retrieve Lines** parameter to instruct the console what line range you want to work with.



## Working with applications

In this chapter, we provide a high-level overview of the J2EE application development and deployment processes. For detailed information about enterprise application deployment and management, see Part 3 of the IBM Redbooks publication *WebSphere Application Server V6.1: System Management and Configuration*, SG24-7304.

We also provide instructions for performing common enterprise application management tasks in WebSphere Application Server, such as:

- ▶ Installing and uninstalling enterprise applications
- ▶ Exporting enterprise applications
- ▶ Starting and stopping enterprise applications
- ▶ Preventing applications from automatic startup
- ▶ Viewing application details in the deployment descriptor
- ▶ Determining the URL of a Servlet or a JSP

The examples in this chapter are based on using the WebSphere Application Server administrative console, which is suitable for the majority of users. Expert users however, might want to become more familiar with using `wsadmin` or `Ant` for application management. In this case, we recommend the following IBM Redbooks publications:

- ▶ *WebSphere Application Server V6 Planning and Design WebSphere Handbook Series*, SG24-6446
- ▶ *WebSphere Application Server V6.1: Planning and Design*, SG24-7305

## 6.1 Overview of developing and deploying J2EE applications

Figure 6-1 shows a high-level view of the stages of application development and deployment for J2EE applications using Rational Application Developer and WebSphere Application Server.

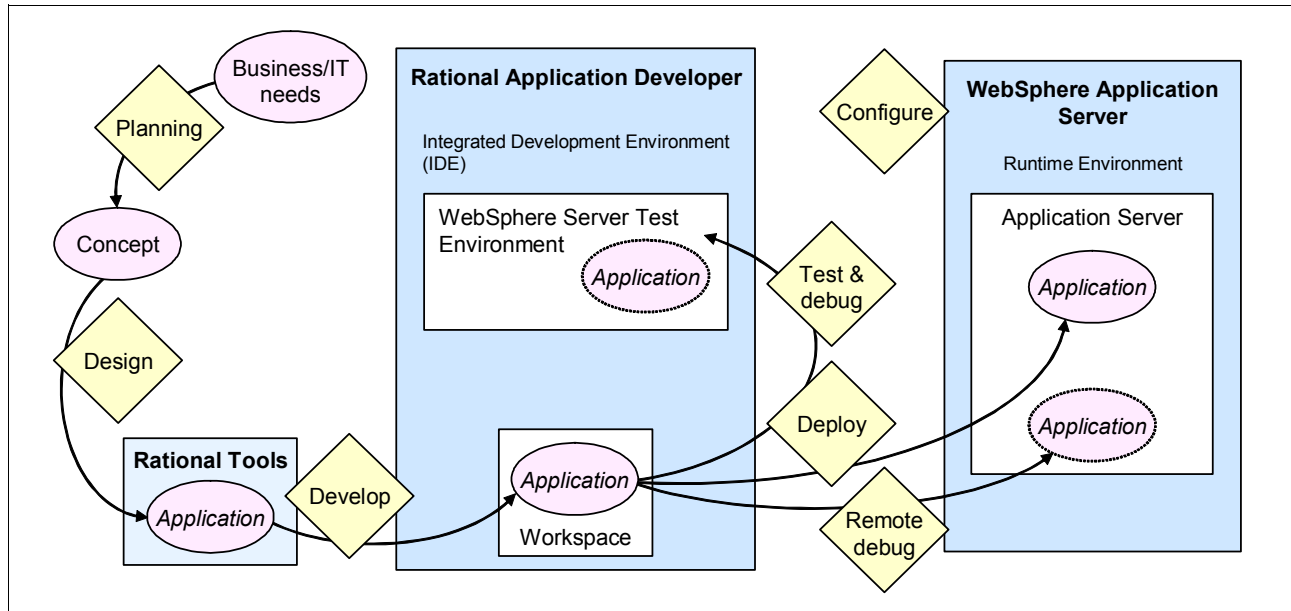

Figure 6-1 J2EE application develop and deploy stages

### 6.1.1 Application design

You can use design tools, such as Rational Software Architect, to model the application using the Unified Modeling Language (UML). The output of the modeling generally consists of use-case scenarios, class diagrams, and starter code that is generated based on the model.

### 6.1.2 Application development

Application development is performed using Rational Application Developer, WebSphere Development Studio Client for iSeries (extension of the Rational tools), Application Server Toolkit, or a comparable IDE to create the enterprise application. You can start by importing pregenerated code from modeling tools, a sample application, or an existing production application, or you can start from scratch.

Rational Application Developer provides many tools and aids to get you started quickly. It also supports team development using Rational ClearCase or CVS, which enables multiple developers to share a single master source copy of the code.

During the development phase, you can perform component testing using the built-in WebSphere Application Server test environment. Rational Application Developer provides server tools that can create and manage servers both in the test environment and on remote server installations. The application is automatically packaged into an EAR file for deployment when you run the application on a server using Rational Application Developer.

### 6.1.3 Application packaging

J2EE applications are packaged into EAR files to be deployed to one or more application servers. A J2EE application contains any or all of the modules, as shown in Table 6-1.

Table 6-1 J2EE application modules

Module	Filename	Contents
Web module	<module>.war	Servlets, JSP files, and related code artifacts.
EJB module	<module>.jar	Enterprise beans and related code artifacts.
Application client module	<module>.jar	Application client code.
Resource adapter module	<module>.rar	Library implementation code that your application uses to connect to enterprise information systems (EIS).

This packaging is automatically done in Rational Application Developer when you export an application for deployment. If you are using another IDE, WebSphere Application Server provides the Application Server Toolkit (AST) for packaging applications. See 7.4, “WebSphere Application Server Toolkit” on page 224 for more information about the Application Server Toolkit.

#### Enhanced EAR files

The enhanced EAR, which was introduced in WebSphere Application Server V6, is a regular J2EE EAR file with additional configuration information for resources that are usually required by J2EE applications. Although adding this extra configuration information at packaging time is not mandatory, it can simplify deployment of J2EE applications to WebSphere Application Server.

When you deploy an enhanced EAR to a WebSphere Application Server V6.1 server, WebSphere can configure the resources that are specified in the enhanced EAR automatically. This automatic configuration reduces the number of steps that are required to set up the WebSphere environment to host the application.

### 6.1.4 Application deployment

Applications are installed on WebSphere Application Server primarily using the administrative console or the wsadmin scripting interface. You can deploy an application to a single server or a cluster. In the case of a cluster, the application is installed on each application server in the cluster.

Installing an application involves:

- ▶ Binding resource references (created during packaging) to actual resources, for example, a data source must be bound to a real database.
- ▶ Defining JNDI names for EJB home objects.
- ▶ Specifying data source entries for entity beans.
- ▶ Binding EJB references to the actual EJB JNDI names.
- ▶ Mapping Web modules to virtual hosts.
- ▶ Specifying listener ports for message-driven beans.
- ▶ Mapping application modules to application servers.
- ▶ Mapping security roles to users or groups.

Using an enhanced EAR file simplifies this installation process. After a new application is deployed, the Web server plug-in configuration file has to be regenerated and copied to the Web server, unless automatic regeneration is configured. See 5.3.6, “Propagating the plug-in configuration file to the Web server” on page 182 for information about regenerating the plug-in configuration file.

### **WebSphere Rapid Deployment**

WebSphere Rapid Deployment is designed to simplify the development and deployment of WebSphere applications. It is a collection of Eclipse plug-ins that can be integrated within development tools or run in a headless mode from a user file system. WebSphere Rapid Deployment is currently integrated into Rational Application Developer and the Application Server Toolkit. Initially, there are features that are only supported in headless mode.

During development, annotation-based programming is used. The developer adds metadata tags into the application source code that generate artifacts needed by the code, thus reducing the number of artifacts the developer has to create.

These applications are packaged into an enhanced EAR file that contains the J2EE EAR file along with deployment information, application resources, and properties (environment variables, JAAS authentication entries, shared libraries, classloader settings, and JDBC resources). During installation, this information is used to create the necessary resources. Moving an application from one server to another also moves the resources.

WebSphere Rapid Deployment automates installation of applications and modules onto a running application server by monitoring the workspace for changes and then driving the deployment process.

### **6.1.5 The flow of a J2EE application**

Figure 6-2 on page 205 shows the typical application flow for Web browser clients that are using either JDBC (from a servlet) or EJB to access application databases.

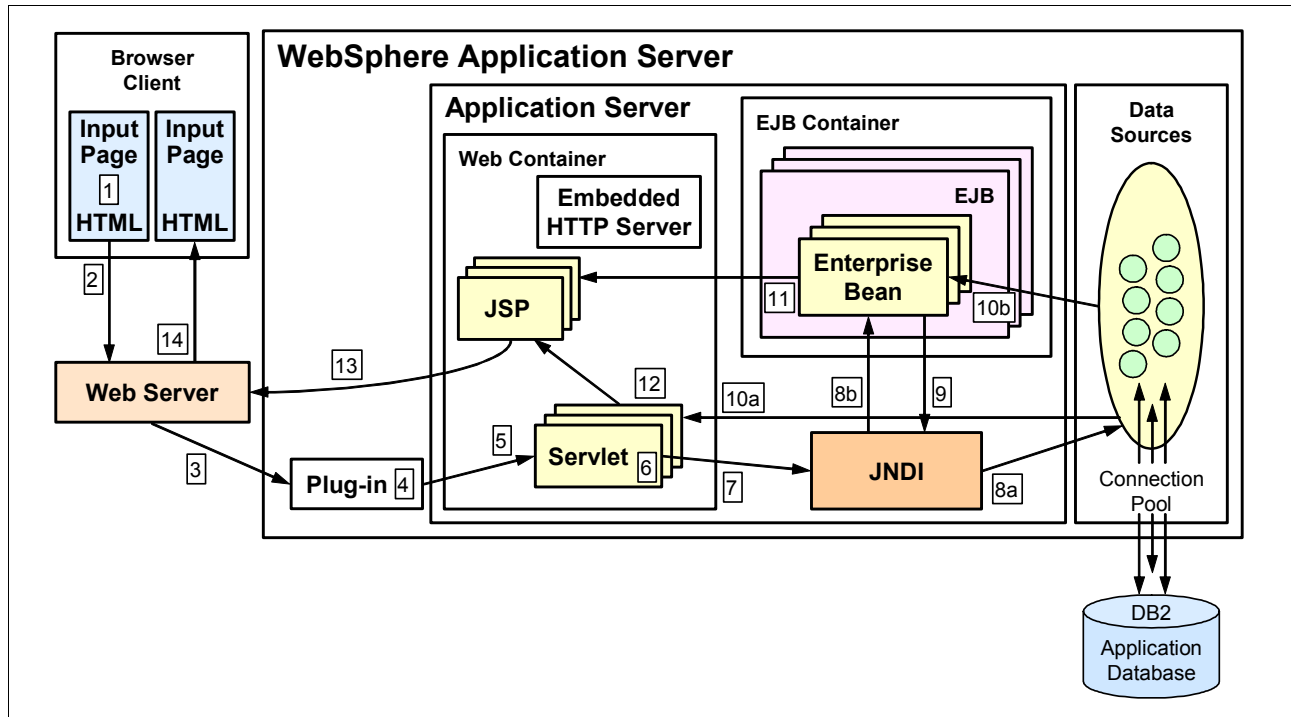

Figure 6-2 J2EE application flow

The typical application flow is as follows:

1. A Web client requests a URL in the browser (input page).
2. The request is routed to the Web server over the Internet.
3. The Web server immediately passes the request to the Web server plug-in. All requests go to the Web server plug-in first.
4. The Web server plug-in examines the URL, verifies the list of host name aliases from which it will accept traffic based on the virtual host information, and chooses a server to handle the request.
5. A stream is created. A stream is a connection to the Web container. It is possible to maintain a connection (stream) over a number of requests. The Web container receives the request and, based on the URL, dispatches it to the proper servlet.
6. If the servlet class is not loaded, the dynamic class loader loads the servlet (servlet init(), then doGet() or doPost()).
7. JNDI is used for lookup of either datasources or EJBs that the servlet requires.
8. Depending upon whether a datasource is specified or an EJB is requested, the JNDI directs the servlet to the corresponding:
  - Database and gets a connection from its connection pool in the case of a data source.
  - EJB container, which then instantiates the EJB when an EJB is requested.
9. If the EJB request involves an SQL transaction, it goes back to the JNDI to look up the datasource.
10. The SQL statement is executed and the retrieved data is sent back, either to the servlet or to the EJB.
11. Data beans are created and handed off to JSPs in the case of EJBs.
12. The servlet sends data to JSPs.

13. The JSP generates the HTML that is sent back through the plug-in to the Web server.
14. The Web server sends the output page (output HTML) to the browser.

## 6.2 Managing applications in WebSphere Application Server V6.1

Applications can be managed using the following methods:

- ▶ Using wsadmin

Using scripts to manage applications is more complicated than using the other methods because requires skill in at least one of the supported scripting languages (for example, Jython) and a complete understanding of the WebSphere Application Server configuration. However, scripting can offer a greater degree of control and can be quite useful in situations where you are performing the same administrative tasks multiple times, or when the tasks are to be done by multiple administrators. We provide an introduction to wsadmin in Chapter 7, “Using WebSphere administrative (wsadmin) scripting” on page 217.

- ▶ Using WebSphere Rapid Deployment

The rapid deployment tools in WebSphere Rapid Deployment provide a shortcut to installing, uninstalling, and updating applications. You can place full J2EE applications (EAR files), application modules (WAR files or EJB JAR files), or application artifacts (Java source files, Java class files, images, JSPs, and so on) into a configurable location on your file system, referred to as the monitored, or project, directory. The rapid deployment tools then automatically detect added or changed parts of these J2EE artifacts and perform the steps that are necessary to produce a running application on an application server.

For information about using this feature, see *Rapid deployment of J2EE applications* topic in the Information Center:

<http://publib.boulder.ibm.com/infocenter/wasinfo/v6r1/index.jsp?topic=/com.ibm.etools.wrd.freeform.doc/topics/cwrdrapid.html>

- ▶ Using the WebSphere Administrative Console

Using the WebSphere administrative console is an easy way to install or update an application. Wizards take you through the process and provide help information at each step. This is the method discussed in this section at a high level. A detailed discussion can be found in Chapter 14 of the IBM Redbooks publication *WebSphere Application Server V6.1: System Management and Configuration*, SG24-7304.

### 6.2.1 Using the WebSphere administrative console to manage applications

To view and manage applications:

1. Access the WebSphere Administrative Console (see 4.2.6, “Accessing the WebSphere Administrative Console” on page 121), select **Applications** → **Enterprise Applications** in the left navigation menu.
2. In the window, you see the list of installed applications and options for performing application management tasks. Select one or more applications by selecting the check box to the left of the application name, and then click an action to perform. The exception to this is the Install option, which installs a new application, and requires no existing application to be selected. See Figure 6-3 on page 207.

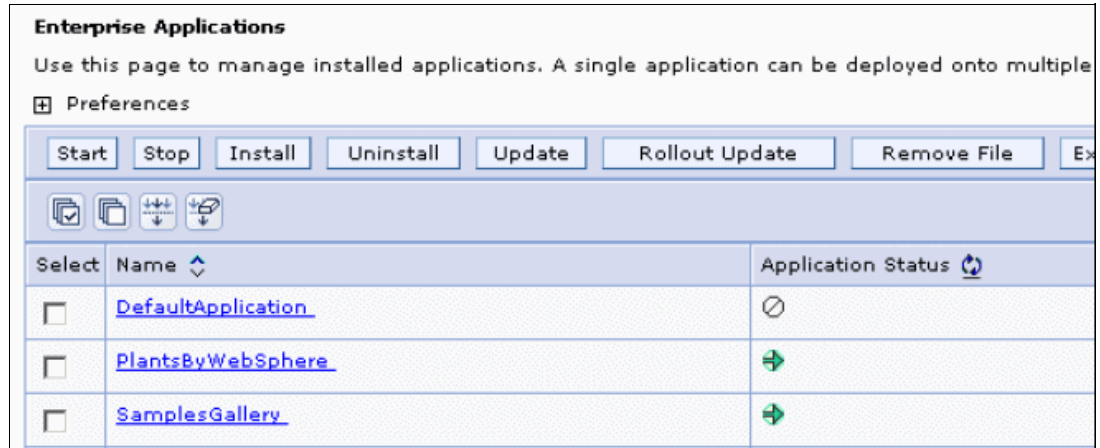

Figure 6-3 Working with enterprise applications

**Note:** The PlantsByWebSphere application is a sample Java 2 Platform, Enterprise Edition (J2EE) application that is supplied with WebSphere Application Server. You do not need to deploy the PlantsByWebSphere.ear file onto the application server because it is installed by default when you create the application server profile. The PlantsByWebSphere application demonstrates several J2EE functions using an online store that specializes in plant and garden tool sales. We use it to illustrate some points in the remainder of this chapter.

The following list describes the actions you can choose from this window:

- ▶ **Start**  
Applications normally start when the server to which they are mapped starts. Exceptions to this include when you initially install the application and when you manually stop the application.
- ▶ **Stop**  
You can stop an application manually without affecting the rest of the application server processes. This is common when you are updating an application or when you want to make an application unavailable to users.
- ▶ **Install**  
The install option takes you through the process of installing a new enterprise application EAR file.
- ▶ **Uninstall**  
Use the uninstall option to remove an application. This removes it from the application servers and from the configuration repository.
- ▶ **Update or Rollout Update**  
You can update applications in several ways. The update options include full application, single module, single file, and partial application.

- ▶ **Remove file**  
With this option, you can remove a single file from an application.
- ▶ **Export**  
Use this option to export an EAR file of the application.
- ▶ **Export DDL**  
Use this option to export Data Definition Language (DDL) files that are found in the application. DDL files typically contain the SQL statements that are necessary to generate the database table for your Container Managed Persistence (CMP) enterprise beans.

## 6.2.2 Installing an enterprise application

To install an enterprise application into a WebSphere configuration, you must install its modules onto one or more application servers. Follow these steps for this task using the WebSphere Administrative Console:

1. Select **Applications** → **Enterprise Applications** → **Install**, or **Applications** → **Install New Application**.
2. Specify the location of the EAR file to install, as shown in Figure 6-4.  
The EAR file that you are installing can be either on the client machine running the Web browser or on any of the nodes in the cell. Click **Next**.

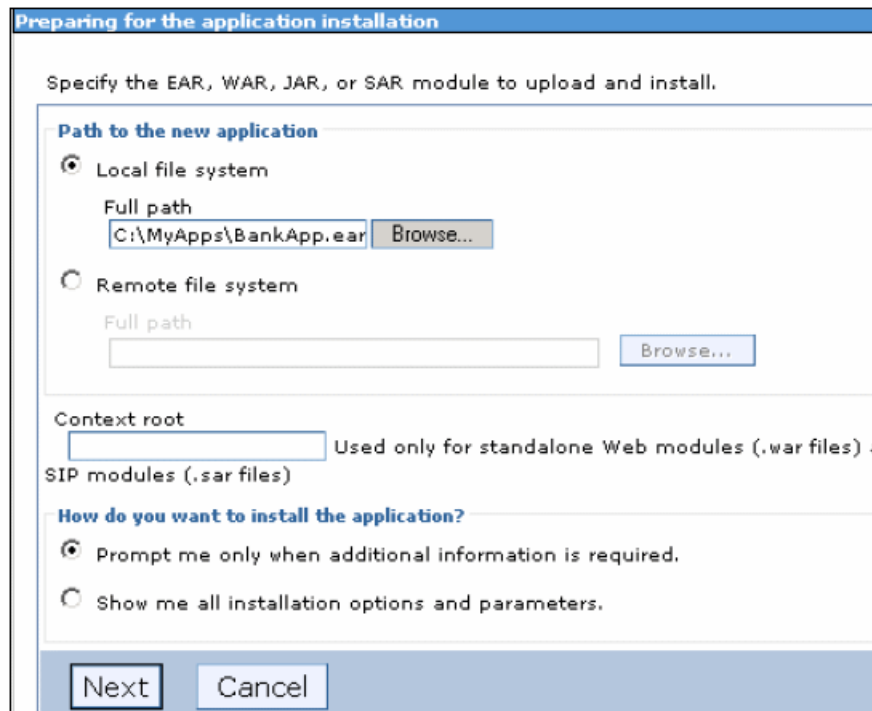

Figure 6-4 Installing an enterprise application

**Note:** New in V6.1 is the Streamline™ installation process, activated using the **Prompt me only when additional information is required** option.

3. The first window has settings that are used during the installation. These settings primarily determine whether default settings are used or if you will override the default settings

during the installation. You can choose to view all installation options and parameters or just prompt when additional information is required. Click **Next**.

4. The rest of the installation process is done in steps. The steps can vary, depending on the contents of the EAR file. The following steps are the typical sequence if you choose the option **Show me all installation options and parameters**:
  - a. Provide options to perform the installation, which includes an option to use embedded configuration values in an Enhanced EAR and the option to pre-compile JSPs.
  - b. Map modules to servers.
  - c. Provide JSP reloading options for Web modules.
  - d. Map shared libraries.
  - e. Initialize parameters for servlets.
  - f. Provide JNDI names for beans.
  - g. Map resource references to resources.
  - h. Map virtual hosts for Web modules.
  - i. Map context roots for Web modules.
  - j. Map security roles to users or groups.
  - k. Summary.
5. Click **Finish** to install the application.
6. Click **Save**.

### 6.2.3 Uninstalling an enterprise application

To uninstall an enterprise application that you no longer need:

1. Select **Applications** → **Enterprise Applications**.
2. Check the application you want to uninstall, and click **Uninstall**.

### 6.2.4 Exporting an enterprise application

If you modified the binding information of an enterprise application, you might want to export the changed bindings to a new EAR file. To export an enterprise application to an EAR file:

1. Select **Applications** → **Enterprise Applications**.
2. Check the application you want to export, and click **Export**.
3. Click the link for the file you want to export.
4. Click **Save**.
5. Specify the directory on the local machine, and click **Save**.

### 6.2.5 Starting an enterprise application

An application starts automatically when the application server to which it is mapped starts. You only need to start an application immediately after installing it or if you manually stopped it.

**Note:** The order in which the applications start depends on the weights you assigned to each of them. The application with the lowest starting weight is started first. Applications that have the same weight are started in no particular order. Enabling the parallel start option for the application server means that you want to start applications with the same weight in parallel.

To view or change the application starting weight, select **Applications** → **Enterprise Applications**. To find the Starting weight field, open the configuration page for the application by clicking the application name.

To start an application from the WebSphere Administrative Console:

1. From the administrative console, select **Applications** → **Enterprise Applications**.
2. Check the application you want, and click **Start**.

**Note:** To start an application, the application server that contains the application has to be started. If not, the application displays in the administrative console as unavailable and you cannot start it.

## 6.2.6 Stopping an enterprise application

To stop an application using the WebSphere Administrative Console:

1. From the administrative console, select **Applications** → **Enterprise Applications**.
2. Check the application you want to stop, and click **Stop**.

## 6.2.7 Preventing an enterprise application from auto-starting

By default, an application starts when the server starts. The only way to prevent this is to disable the application from running on the server:

1. From the administrative console, select **Applications** → **Enterprise Applications**.
2. Click the application name to open the configuration.
3. Select **Target specific application status** in the Detail Properties table.
4. Select the server for which you want to disable the application.
5. Click the **Disable Auto Start** button.
6. **Save** the configuration.

## 6.2.8 Viewing application deployment details

The administrative console does not display the deployed servlets, JSPs, or EJBs directly on the console. However, you can use the console to display XML deployment descriptors for the enterprise application, Web modules, and EJB modules.

To view the deployment descriptor for an application:

1. From the console navigation tree, select **Applications** → **Enterprise Applications**.
2. Click the application that you are interested in.
3. Under the **Configuration** tab, select **Detail Properties** → **View Deployment Descriptor**.

Figure 6-5 shows the deployment descriptor window for the PlantsByWebSphere enterprise application. The **Configuration** tab shows you the structure defined by the deployment descriptor:

- The name and description of the enterprise application
- The Web modules or WAR files and their context roots
- The EJB modules and their associated JAR files
- The security roles associated with the enterprise application

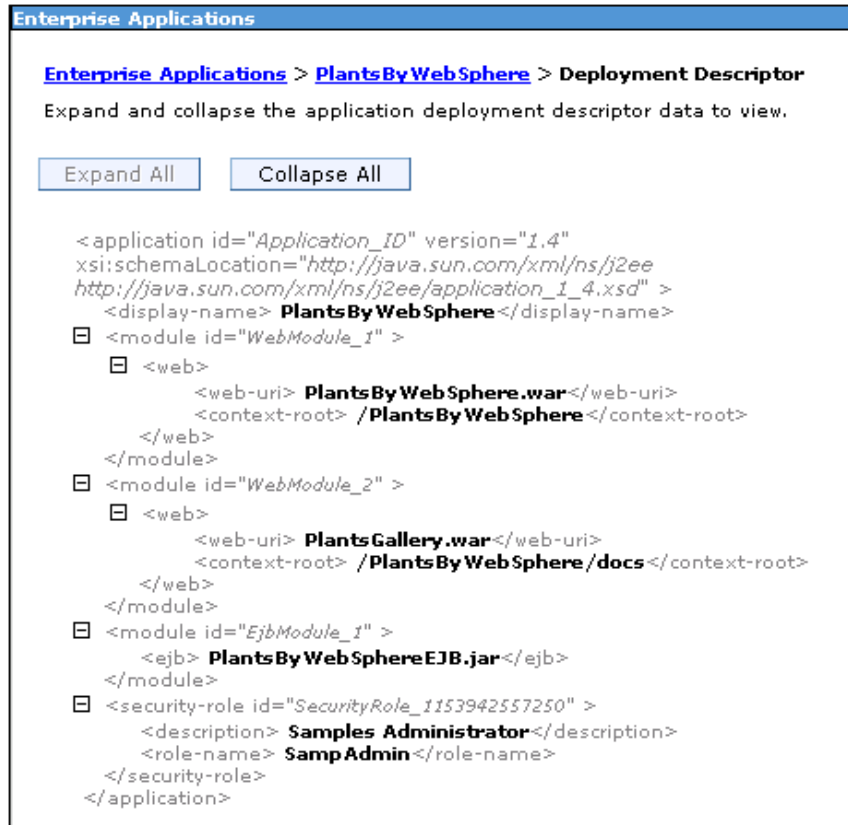

Figure 6-5 Enterprise application deployment descriptor

## Viewing EJB modules

To see the EJBs that are part of an enterprise application, do the following in the WebSphere administrative console:

1. Select **Applications** → **Enterprise Applications**.
2. Click the application that you are interested in. We selected **PlantsByWebSphere**.
3. Select **Modules Items** → **Manage Modules**.
4. Click the EJB module you want to view.
5. Click **Additional Properties** → **View Deployment Descriptor** to see the EJB deployment descriptor. See Figure 6-6 on page 212.

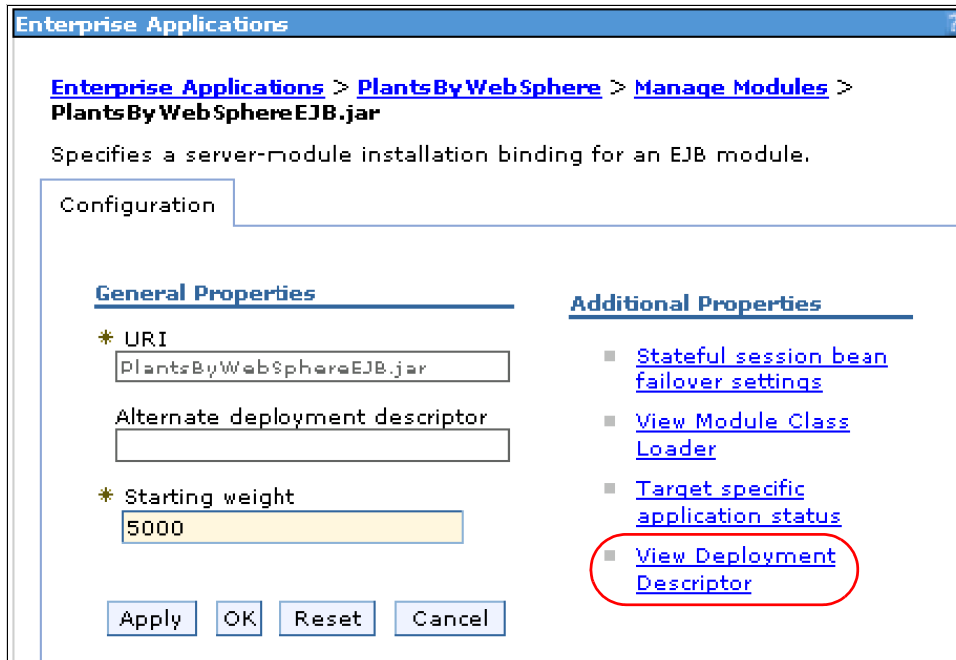

Figure 6-6 Viewing an EJB module configuration

## Viewing Web modules

To see the servlets and JSPs that are part of an enterprise application:

1. Select **Applications** → **Enterprise Applications**.
2. Click the application that you are interested in.
3. Select **Manage Modules** under **Modules**.
4. Click the Web module you want to view.
5. Click **View Deployment Descriptor** to see the details of the Web module content. See Figure 6-7 on page 213.

[Enterprise Applications](#) > [PlantsByWebSphere](#) > [Manage Modules](#) > [PlantsByWebSphere.war](#)

Use this page to configure an instance of a deployed Web module in the application. This page contains deployment-specific information for a Web module and session management settings.

Configuration

General Properties	Web Services Properties
<p>* URI  <input type="text" value="PlantsByWebSphere.war"/></p> <p>Alternate deployment descriptor  <input type="text"/></p> <p>* Starting weight  <input type="text" value="10000"/></p> <p>* Class loader order  <input type="text" value="Classes loaded with parent class loader first"/></p> <p><input type="button" value="Apply"/> <input type="button" value="OK"/> <input type="button" value="Reset"/> <input type="button" value="Cancel"/></p>	<ul style="list-style-type: none"> <li>▪ <a href="#">Web services client bindings</a></li> <li>▪ <a href="#">View Web services client deployment descriptor extension</a></li> </ul>
	Web Services Security Properties
	<ul style="list-style-type: none"> <li>▪ <a href="#">Web services: Client security bindings</a></li> </ul>
	Additional Properties
	<ul style="list-style-type: none"> <li>▪ <a href="#">View Module Class Loader</a></li> <li>▪ <a href="#">Target specific application status</a></li> <li>▪ <a href="#">View Deployment Descriptor</a></li> <li>▪ <a href="#">View Portlet Deployment Descriptor</a></li> <li>▪ <a href="#">Session Management</a></li> <li>▪ <a href="#">Web Module Proxy Configuration</a></li> </ul>

Figure 6-7 View a Web module configuration

## 6.2.9 Determining the URL of a servlet or JSP

The URL for a servlet or JSP is the path that is used to access it from a browser, for example `http://mysystem.ibm.com/snoop`. The URL is partly defined in the deployment descriptor that is provided in the EAR file and partly defined in the deployment descriptor for the Web module that contains the servlet or JSP. You must determine what the URL is in order to access the application.

To find the URL for a servlet or JSP:

1. Find the context root of the Web module that contains the servlet.
2. Find the URL for the servlet.
3. Find the virtual host where the Web module is installed.
4. Find the aliases by which the virtual host is known.
5. Combine the virtual host alias, context root, and URL pattern to form the URL request of the servlet/JSP. The result is what a user enters in the browser to access the enterprise application.

As an example, use the following steps to determine the URL that is used to access the Snoop servlet:

1. Find the context root of the Web module `DefaultWebApplication` of the `DefaultApplication` enterprise application. This Web module contains the Snoop servlet:
  - a. From the WebSphere Administrative Console navigation tree, select **Applications** → **Enterprise Applications**.
  - b. Click the application that you are interested in (**DefaultApplication** in our case).

- c. On the **Configuration** tab, select **Context Root for Web Modules**. (Figure 6-8). You can see:
  - There is only one Web module in this application, DefaultWebApplication.
  - The context root for the DefaultWebApplication Web module is “/”. We will use this information later.

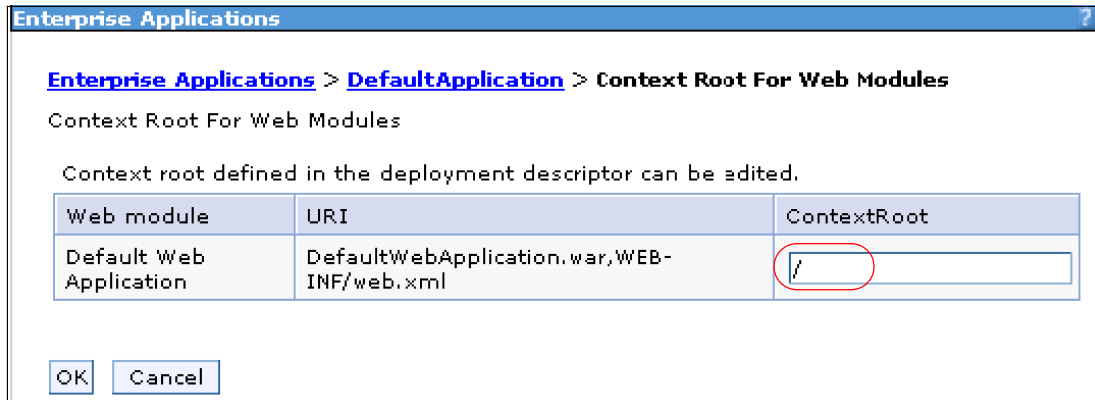

Figure 6-8 Context root for the Web modules in DefaultApplication

- d. Click **OK** to return to the DefaultApplication configuration.
2. Find the URL for the Snoop servlet:
    - a. In the DefaultApplication configuration page, select **Manage Modules**.
    - b. Click the **DefaultWebApplication** Web module to see the general properties.
    - c. Click **View Deployment Descriptor**, which displays the Web module properties window, as shown in Figure 4-41 on page 131. Note that the URL pattern for the Snoop servlet starting from the Web module context root is “/snoop/\*”. The Web module context root (from Figure 6-8) was “/”.

[Enterprise Applications](#) > [DefaultApplication](#) > [Manage Modules](#) > [DefaultWebApplication.war](#) > **Deployment Descriptor**

Expand and collapse the application deployment descriptor data to view.

```

<web-app id="WebApp_ID" >
  <display-name> Default Web Application</display-name>
  <description> This is the IBM WebSphere Application Server Default Web Application.</description>
  ⊕ <servlet id="Servlet_1" >
  ⊕ <servlet id="Servlet_2" >
  ⊕ <servlet id="Servlet_3" >
  ⊖ <servlet-mapping id="ServletMapping_1" >
    <servlet-name> Snoop Servlet</servlet-name>
    <url-pattern> /snoop/*</url-pattern>
  </servlet-mapping>
  ⊖ <servlet-mapping id="ServletMapping_2" >
    <servlet-name> Hello Pervasive Servlet</servlet-name>
    <url-pattern> /hello</url-pattern>
  </servlet-mapping>
  ⊖ <servlet-mapping id="ServletMapping_3" >
    <servlet-name> Hit Count Servlet</servlet-name>
    <url-pattern> /hitcount</url-pattern>
  </servlet-mapping>
  ⊕ <welcome-file-list id="WelcomeFileList_1" >
  ⊕ <error-page id="ErrorPage_1" >

```

Figure 6-9 DefaultWebApplication Web module deployment descriptor

- d. Note that as you navigate through the windows, a navigation path is displayed below the Messages area. Click **DefaultApplication** to return to the application configuration page.
3. Find the virtual host where the DefaultWebApplication Web module is installed:
  - a. In the DefaultApplication configuration page, select **Virtual hosts** under Web Module Properties, which displays all of the Web modules that are contained in the enterprise application, and the virtual hosts in which they were installed. See Figure 6-10. The DefaultWebApplication Web module is installed on the default\_host virtual host.

[Enterprise Applications](#) > [DefaultApplication](#) > **Virtual hosts**

Virtual hosts

Specify the virtual host where you want to install the Web modules that are contained in your application. You can install Web modules on the same virtual host or disperse them among several hosts.

Apply Multiple Mappings

Select	Web module	Virtual host
<input type="checkbox"/>	Default Web Application	default_host

Figure 6-10 List of Virtual Hosts

4. Find the host aliases for the default\_host virtual host:
  - a. From the WebSphere Administrative Console navigation tree, select **Environment** → **Virtual Hosts**.
  - b. Click **default\_host**.
  - c. Select **Additional Properties** → **Host Aliases**. This shows the list of aliases by which the default\_host virtual host is known, as shown in Figure 6-11.

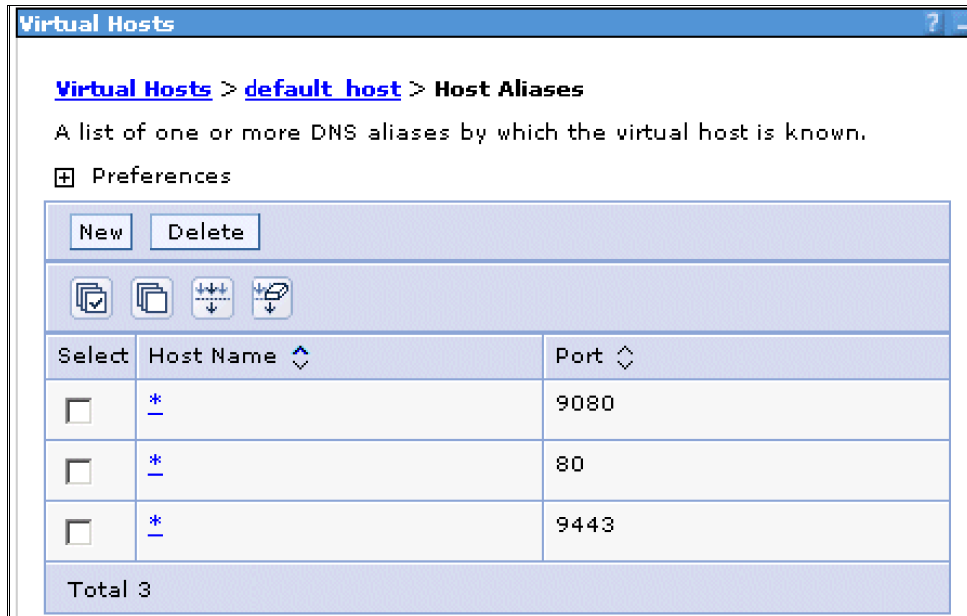

Figure 6-11 Default\_host virtual host aliases

**Note:** The aliases are composed of a DNS host name and a port number. The host aliases for the default\_host virtual host are \*:80, \*:9080 and \*:9443, with “\*” meaning any host name.

5. Combine the virtual host alias, context root and URL pattern to form the URL request of the Snoop servlet. Requests for the servlet with any of the following URLs will map to the default\_host virtual host:

```
http://<hostname>:80/snoop
http://<hostname>:9080/snoop
https://<hostname>:9443/snoop
```



## Using WebSphere administrative (wsadmin) scripting

In this chapter, we introduce the WebSphere scripting interface, wsadmin, and describe how some of the tasks that WebSphere administrators perform can be done using wsadmin. There are two types of tasks: the *operational task* and the *configurational task*. Operational tasks deal with currently running objects in WebSphere installation, and configurational tasks deal with the configuration of WebSphere installations.

We also introduce the WebSphere Application Server Toolkit (AST) and tell you how to use it with content assist to make creating automation scripts easier.

For further information about this subject, refer to the IBM Redbooks publication *WebSphere Application Server V6.1: System Management and Configuration*, SG24-7304.

## 7.1 Developing automation scripts

The WebSphere administrative scripting tool (wsadmin) is a non-graphical command interpreter environment that enables you to run administrative operations on an application server in a scripting language. The wsadmin tool is intended for production environments and unattended operations.

There are five wsadmin objects available when you use wsadmin scripts:

- ▶ **AdminControl**

The *AdminControl* scripting object is used for operational control. It communicates with MBeans that represent live objects that are running a WebSphere server process. It includes commands to query existing running objects and their attributes and invokes operations on the objects. In addition to the operational commands, the AdminControl object supports commands to query information about the connected server, convenient commands for client tracing, reconnecting to a server, and starting and stopping a server.

- ▶ **AdminConfig**

The *AdminConfig* object manages the configuration information that is stored in the repository. This object communicates with the WebSphere Application Server configuration service component to make configuration inquiries and changes. You can use it to query existing configuration objects, create configuration objects, modify existing objects, and remove configuration objects. In a distributed server environment, the AdminConfig commands are available only if a scripting client is connected to the Deployment Manager. When connected to a node agent or a managed application server, the AdminConfig commands are not available because the configuration for these server processes are copies of the master configuration that resides in the Deployment Manager.

- ▶ **AdminApp**

The *AdminApp* object can update application metadata, map virtual hosts to Web modules, and map servers to modules for applications that are already installed. Perform changes to an application, such as specifying a library for the application to use or setting session management configuration properties, using the AdminConfig object.

- ▶ **AdminTask**

The *AdminTask* object is used to access a set of task-oriented administrative commands that provide an alternative way to access the configuration commands and the running object management commands. The administrative commands run simple and complex commands. The administrative commands are discovered dynamically when the scripting client is started. The set of available administrative commands depends on the edition of WebSphere Application Server that you install. You can use the AdminTask object commands to access these commands. Two run modes are always available for each administrative command, namely the batch and interactive mode. When you use an administrative command in interactive mode, you go through a series of steps to collect your input interactively. This process provides you with a text-based wizard and a similar user experience to the wizard in the administrative console. You can also use the help command to obtain help for any of the administrative commands and the AdminTask object.

- ▶ **Help**

The *Help* object provides information about the available methods for the four management objects as well as information about operations and attributes of running MBeans. For detailed information about using Help refer to 7.3, "Using wsadmin help" on page 223.

## 7.1.1 Execution environment

The AdminConfig, AdminTask, and AdminApp objects all handle configuration functionality. You can invoke configuration functions with or without being connected to a server. Only the AdminControl object requires the server to be started because you can only invoke its commands on running JMX™ MBeans.

If a server is running, we do not recommend that you start the wsadmin scripting client in local mode because configuration changes made in local mode are not reflected in the running server configuration. The reverse is also true. In connected mode, the availability of the AdminConfig commands depend on the type of server to which the scripting client is attached to. We do not advise that you perform configuration changes to a node agent or managed application server.

To start the wsadmin client in local mode, you can specify **-conntype none**, for example, if you issue the **wsadmin -profileName nbsvr01 -conntype none** command, wsadmin is started in interactive mode using the wsadmin.properties file for WebSphere Application Server profile nbsvr01, but does not connect to the server.

**Note:** For the purposes of this discussion, we refer to the methods of the AdminControl, AdminConfig, AdminApp, AdminTask, and Help objects as commands.

The WebSphere Administrative (wsadmin) scripting client supports two scripting languages: Java Tcl (Jacl) and Java Python (Jython).

The Jython syntax for wsadmin is the strategic direction for WebSphere administrative automation. With the Version 6.1 release, WebSphere is significantly enhancing administrative functions and tooling to support product automation in general and the use of the Jython syntax in particular. The following new Jython scripting related enhancements are provided in WebSphere Application Server V6.1:

- ▶ WebSphere Automation Tools

An Eclipse-based, full function development environment for wsadmin scripts, which includes Jython editor, color-coded keyword highlighting, statement completion assistance, script execution, and debugging support. For more information, see 7.4, “WebSphere Application Server Toolkit” on page 224.

- ▶ Administrative Console Command Assist

A feature of the WebSphere Administrative Console that displays the wsadmin command that is equivalent to the action taken by the user who interacts with the console. The output from the Command Assist feature is transferred directly to the Jython Editor, which makes development of Jython scripts based on console actions easy. For more information, see 7.4.6, “Getting content assistance and tips in the Jython editor” on page 236.

- ▶ IBM Jacl to Jython Conversion Assistant

A program that assists in the conversion of Jacl syntax wsadmin scripts into equivalent Jython syntax wsadmin scripts. For more information, see 7.4.7, “Migrating administrative Jacl scripts to Jython” on page 236.

All future enhancements in the area of WebSphere scripting focus on using the Jython syntax. Jacl remains as a component that is shipped with WebSphere Application Server for at least two full releases. No new tooling or explicit enhancements will be created for Jacl syntax.

## 7.2 Invoking wsadmin

WebSphere Application Server provides a scripting interface that is based on the Bean Scripting Framework (BSF) called *wsadmin*. BSF is an open source project to implement an architecture for incorporating scripting into Java applications and applets. The BSF architecture works as an interface between Java applications and scripting languages. Because *wsadmin* uses BSF, it can make various Java objects available through language-specific interfaces to scripts.

The *wsadmin* command file resides in the bin directory of every profile for an application server, for example, in the default base install, you would find the command in:

```
/QIBM/ProdData/WebSphere/AppServer/V61/Base/bin
```

If you execute the *wsadmin* command from this directory, by default it uses properties as specified in the *wsadmin.properties* file in directory:

```
/QIBM/ProdData/WebSphere/AppServer/V61/Base/properties
```

Figure 7-1 on page 221 shows part of the *wsadmin.properties* file. It defines SOAP as the connection method and uses the default SOAP port number of 8880. It also defines *Jacl* as the scripting language.

**Important:** The *wsadmin.properties* file, by default, specifies *Jacl* as the scripting language. Examples in this book are in *Jython* because this is the strategic direction for WebSphere administrative scripting. Edit your profile's *wsadmin.properties* file to specify the language that is used in your script files. By default, the *wsadmin.properties* file is located in:

```
/QIBM/UserData/WebSphere/AppServer/V61/Base/profiles/<profile_name>/properties
```

```

#-----
# Properties file for scripting client
#   Base App Server version
#-----
#
#-----
# The connectionType determines what connector is used.
# It can be SOAP or RMI.
# The default is SOAP.
#-----
com.ibm.ws.scripting.connectionType=SOAP
#com.ibm.ws.scripting.connectionType=RMI

#-----
# The port property determines what port is used when attempting
# a connection.
# The default SOAP port for a single-server installation is 8880
#-----
com.ibm.ws.scripting.port=8880

#-----
# The host property determines what host is used when attempting
# a connection.
# The default value is localhost.
#-----
com.ibm.ws.scripting.host=localhost

#-----
# The defaultLang property determines what scripting language to use.
# Supported values are jacl and jython.
# The default value is jacl.
#-----
com.ibm.ws.scripting.defaultLang=jacl

#-----

```

Figure 7-1 *wsadmin.properties*

Therefore if you want to connect to a server other than the default server, use the `-profileName` parameter when you use the `wsadmin` tool.

You can, for instance, for server name *nbsvr01* do the following:

1. Start a QShell session with the STRQSH command.
2. Change the directory so that you are in the product bin directory. For the default install location, the command is:

```
cd /QIBM/ProdData/WebSphere/AppServer/V61/Base/bin
```

3. Invoke `wsadmin` to connect to your running application server. For our WebSphere Application Server *nbsvr01*, the command is:

```
wsadmin -profileName nbsvr01
```

wsadmin reads properties from the wsadmin.properties file of the specified profile, which, in our case, is located in:

```
/QIBM/UserData/WebSphere/AppServer/V61/Base/profiles/nbsvr01/properties
```

4. After wsadmin is launched in this way, you are in wsadmin *interactive* mode and administrative objects and built-in language objects can be invoked, as shown in Example 7-1. Type the commands shown in **bold**.

*Example 7-1 Interactive command invocation*

---

```
wsadmin>  
> AdminControl.getNode()  
RCHAS60_nbsvr01'
```

---

**Tip:** If this command syntax gives a WASX7015E exception, you may still be in Jacl mode.

5. To end the interactive execution environment, type **quit**, and press Enter.

This works fine if there are only a few simple commands that you want to execute; however, if you are involved in more complex or repetitive operations, you should put your commands in a script file and run the script file.

## 7.2.1 Running wsadmin script files

The `-f` option is used to execute a script file. Example 7-2 shows a two-line Jython script named `myScript.py`. The script has a `.py` extension to reflect the Jython language syntax of the script. The extension has no significance to wsadmin however.

*Example 7-2 Jython script*

---

```
print "This is an example Jython script"  
print "+AdminControl.getNode()+"
```

---

In our case, we created a *scripts* directory in the root of the system integrated file system, and put our scripts there.

The following steps outline how we can execute the script in our environment:

1. Start a QShell session with the STRQSH command.
2. Change the directory so that you are in your product bin directory. For our installation, we used the command:

```
cd /QIBM/ProdData/WebSphere/AppServer/V61/Base/bin
```

3. Invoke *wsadmin* to connect to your running application server, and run the `myScript` file. For our WebSphere Application Server *nbsvr01*, the command is:

```
wsadmin -profileName nbsvr01 -f /scripts/myScript.py
```

Figure 7-2 on page 223 shows the resulting output.

```

> wsadmin -profileName nbsvr01 -f /scripts/myScript.py
WASX7209I: Connected to process "nbsvr01" on node RCHAS60_nbsvr01 using SOAP
connector; The type of process is: UnManagedProcess
This is an example Jython script
RCHAS60_nbsvr01
$

```

Figure 7-2 Running a Jython script

## 7.3 Using wsadmin help

The examples we use in this section are for the Jython scripting language. Confirm that your `wsadmin.properties` file for your server profile is set to Jython. Refer to 7.2, “Invoking wsadmin” on page 220.

To enter wsadmin interactive mode:

1. Start a QShell session with the STRQSH command.
2. Change your directory so that you are in your product bin directory. For our installation, we use the command:

```
cd /QIBM/ProdData/WebSphere/AppServer/V61/Base/bin
```

3. Invoke `wsadmin` to connect to your running application server. For our WebSphere Application Server `nbsvr01`, the command is:

```
wsadmin -profileName nbsvr01
```

If you get the following message, you are still in Jacl mode.

```
WASX7029I: For help, enter: "$Help help"
```

If you are in Jython mode you should get a message of the form:

```
WASX7031I: For help, enter: "print Help.help()"
```

The command `print Help.help()` provides general help information for the objects that are supplied by wsadmin for scripting: `Help`, `AdminApp`, `AdminConfig` and `AdminControl`. It also provides information about a variety of commands that are available to get information about the operations, attributes, and other interface information.

More detailed information about each of these commands is available by using the `help` command of `Help` and supplying the name of the command as an argument, for example, to get a list of the public methods that are available for the `AdminControl` object, enter the command:

```
wsadmin>print Help.AdminControl()
```

To get a detailed description of a specific object method and the parameters that it requires, invoke the `help()` method of the target object with the method name as a parameter to the `help()` method:

```
wsadmin>print AdminControl.help('completeObjectName')
```

To list the available object names, use the command:

```
wsadmin>AdminControl.queryNames('*')
```

This is where the WebSphere Application Server Toolkit can be of great assistance. The object names are not always obvious, but the WebSphere administration command assists

along with the content assist and content tip functions of the WebSphere Application Server Toolkit make it much easier to discover the appropriate syntax to use.

## 7.4 WebSphere Application Server Toolkit

The WebSphere Application Server Toolkit (AST) helps you create, test, and deploy applications with WebSphere Application Server Version 6.1. All the tools are integrated into an Eclipse-based workbench to simplify the development process.

The following list is a typical scenario for developing applications using the WebSphere Application Server Toolkit:

- ▶ A team of Application Developers write code on their personal workstations. WebSphere Application Server Toolkit supports a variety of technologies, such as J2EE 1.4, Enterprise JavaBeans 2.1, Web services, XML, and portlets.
- ▶ Application Developers check their code into a source control system, which allows them to manage, share, and synchronize resources. The workbench can be configured to work with Rational ClearCase, CVS, or other source control systems.
- ▶ Application Developers deploy Web applications to a unit test server where they can test and debug their code.
- ▶ A Build Engineer generates scripts for building, packaging, and deploying the application. They run daily or weekly builds of the application. A Jython editor simplifies the development and maintenance of wsadmin scripts.
- ▶ Test Engineers perform functional testing on the application.
- ▶ The Solution Deployer deploys the completed application onto a production server

**Attention:** In this topic, we concentrate on using the Jython editor in AST and the development and maintenance of wsadmin scripts using AST.

You can use the WebSphere Administration Command assist tool to generate WebSphere administrative (wsadmin) commands in the Jython scripting language as you interact with the WebSphere Administrative Console. When you perform server operations in the WebSphere Administrative Console, the WebSphere Administration Command assist tool captures and displays the wsadmin commands that are issued. You can transfer the output from the WebSphere Administration Command view directly to a text editor, such as the Jython editor, which enables you to develop Jython scripts based on actual console actions.

### 7.4.1 Starting the WebSphere Application Server Toolkit (AST)

The Application Server Toolkit is available on CD-ROM in the WebSphere Application Server CD-ROM package.

Install WebSphere Application Server Toolkit using the installation guide. The installation guide for WebSphere Application Server Toolkit is available at the following Web site, where x is the CD-ROM drive with the WebSphere Application Server Toolkit CD.

```
x:/readme/readme_install_ast.html
```

To start the toolkit from your workstation:

1. Click **Start** → **Programs** → **IBM WebSphere** → **Application Server Toolkit V6.1** → **Application Server Toolkit**.

2. In the Workspace Launcher dialog, specify the workspace directory, and click **OK** to launch the Integrated Development Environment (IDE).
3. Select the Project Explorer view for your work:
  - a. Click **Window** → **Show View** → **Other** → **Basic** → **Project Explorer** → **OK**. The Project Explorer view is displayed in a panel of the workbench.

## 7.4.2 Creating a server connection

Although you can use the WebSphere Application Server Toolkit as a standalone development environment, for features, such as the *Administrative Console Command Assist*, you need a connection to your WebSphere Application Server.

To establish this connection:

1. To create a server connection we need to specify the correct port number for the SOAP connection. To obtain the configured port number for your server profile, use IBM Web Administration for i5/OS, as shown in Figure 7-3. For our profile *nbsvr01*, we are using a SOAP port number of 51006. Note the port number for later use.

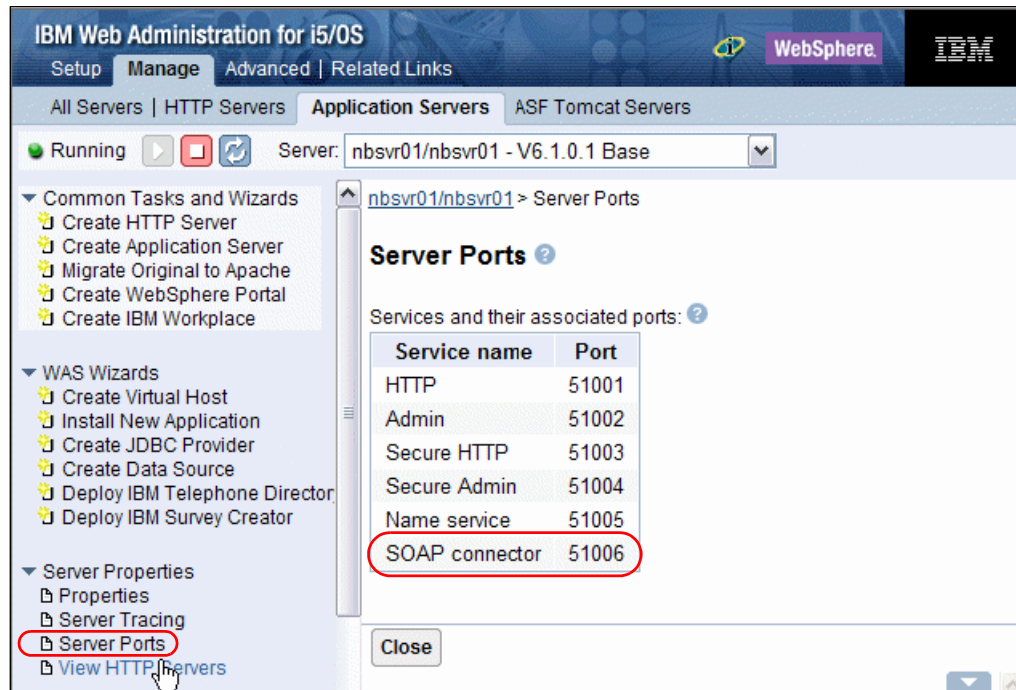

Figure 7-3 Discovering the SOAP Port Number

2. Start the **WebSphere Application Server** toolkit.
3. Select the server view for your work, by clicking **Window** → **Show View** → **Other** → **Server** → **Servers** → **OK**. The Servers Pane is displayed in a panel of the workbench as shown in Figure 7-4 on page 226.

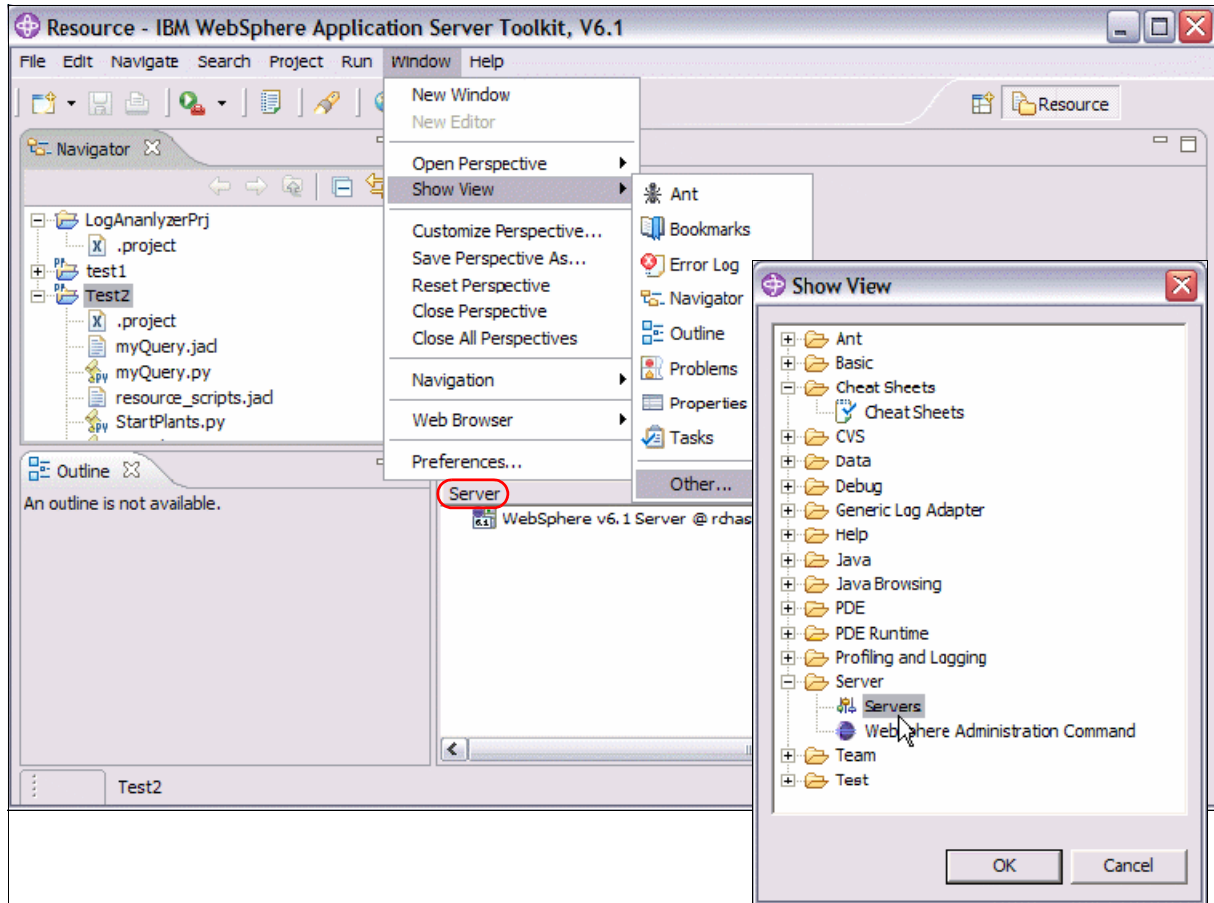

Figure 7-4 AST Server View

4. Right-click in the Servers Pane, and select **New** → **Server**.
5. In the Define a New Server dialog, enter the host name of your server system (rchas60 in our case). Click **Next**. See Figure 7-5 on page 227.

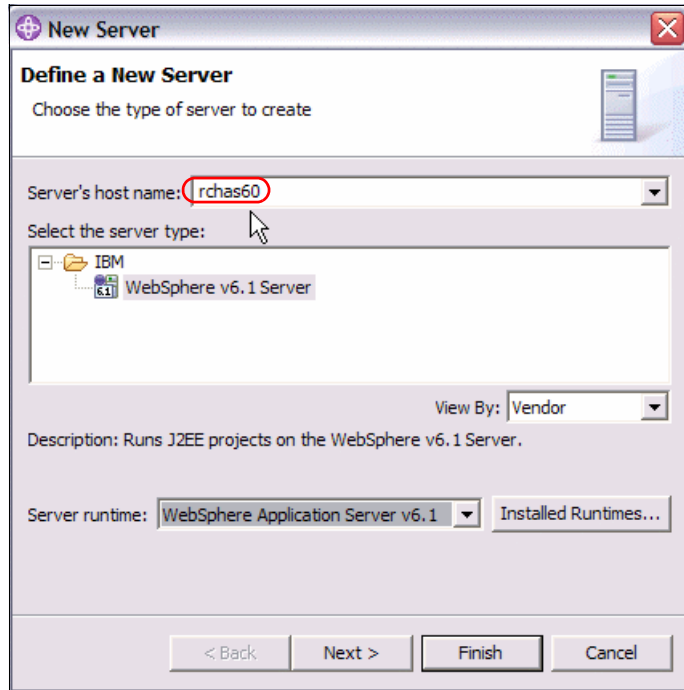

Figure 7-5 AST New Server

6. In the WebSphere Server Settings dialog (Figure 7-6 on page 228), you have the option of using RMI or SOAP protocols. In our example, we use SOAP. Enter the port number noted in step 1. In our case, the port number was *51006*. If security is enabled for your WebSphere Application Server profile, you must also enter your User ID and Password. Enter your WebSphere Application Server profile name in the Server name field. Our profile name is **nbsvr01**. Also check the server type. If it is a Network Deployment server, you must also supply the Network Deployment server name. An example is shown in Figure 7-6 on page 228.
7. Click **Finish**.

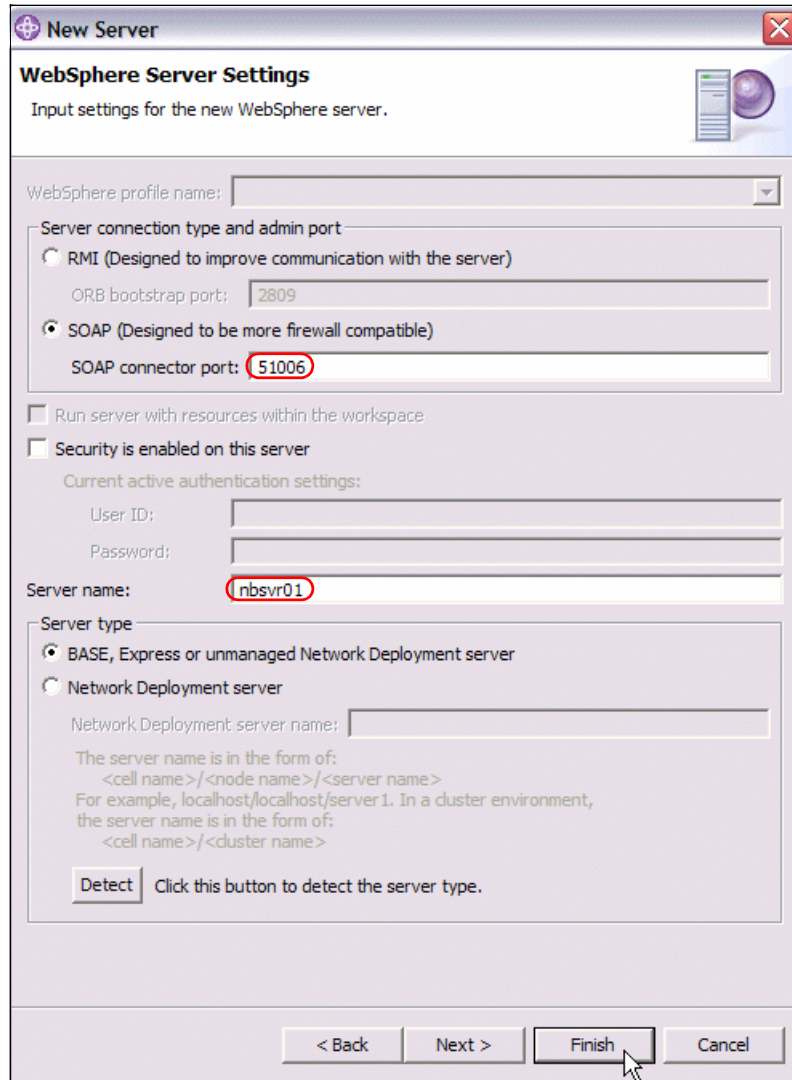

Figure 7-6 AST WebSphere Server settings

### 7.4.3 Creating a Jython Project

To create a Jython project:

1. From the menu, select **File** → **New** → **Project**. The New Project wizard opens, as shown in Figure 7-7 on page 229.

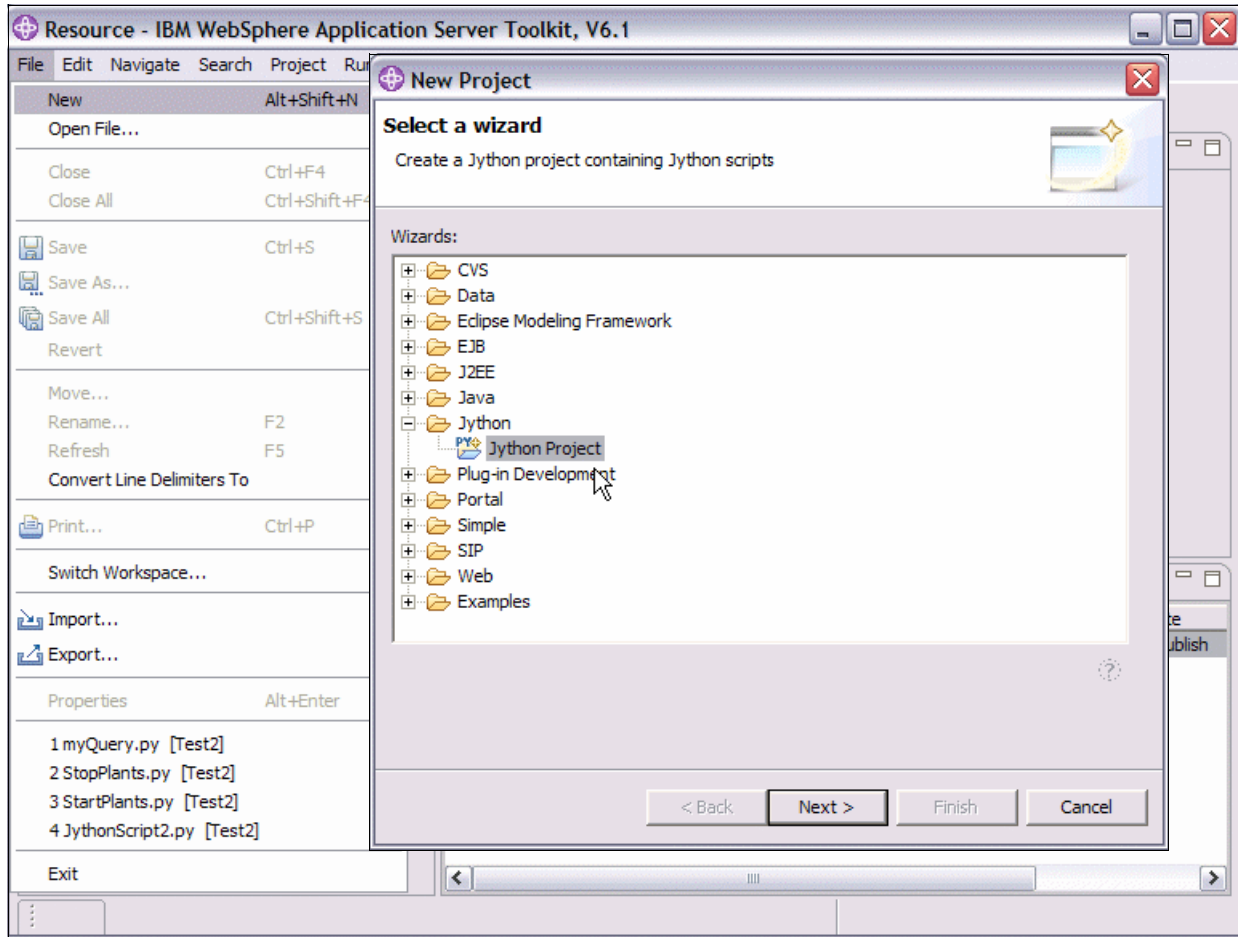

Figure 7-7 Jython Project Wizard

2. Expand the Jython folder, and select **Jython Project**. Click **Next**. The New Jython Project wizard opens.
3. In the Project name, type a name for the new Jython project, as shown in Figure 7-8.

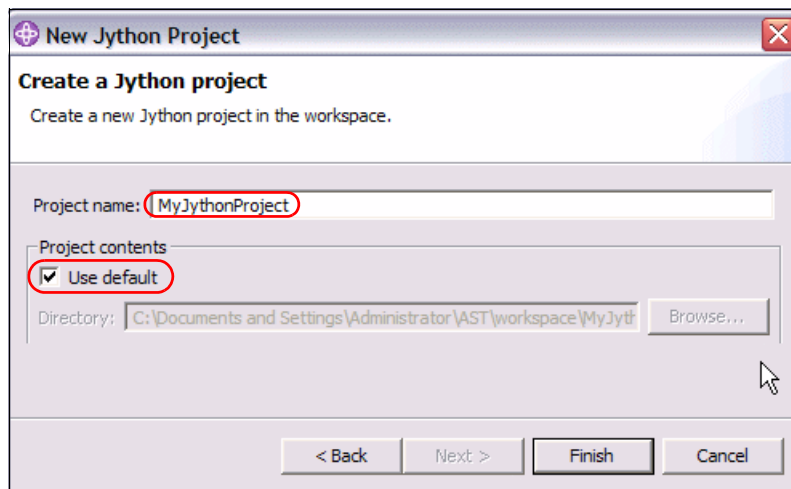

Figure 7-8 Create a Jython project

- (Optional) Clear the **Use default** check box to specify a directory other than the default. In the Directory field, specify a location on your local file system for the new project.

**Tip:** In our case, we had a mapped drive from our workstation to the System i server, so that we could actually specify the target directory directly on the System i, which allowed us to execute the scripts directly on the System i without having to do the extra step of exporting the Jython script files.

- Click **Finish**.

You can now begin creating or importing content for your Jython project using the New Jython Script File wizards or the Import wizards available from the File menu.

## 7.4.4 Creating a Jython script file

After you create a Jython project, you can create a Jython script file as follows:

- From the menu bar, select **File** → **New** → **Other**. The New wizard (Figure 7-9) opens.

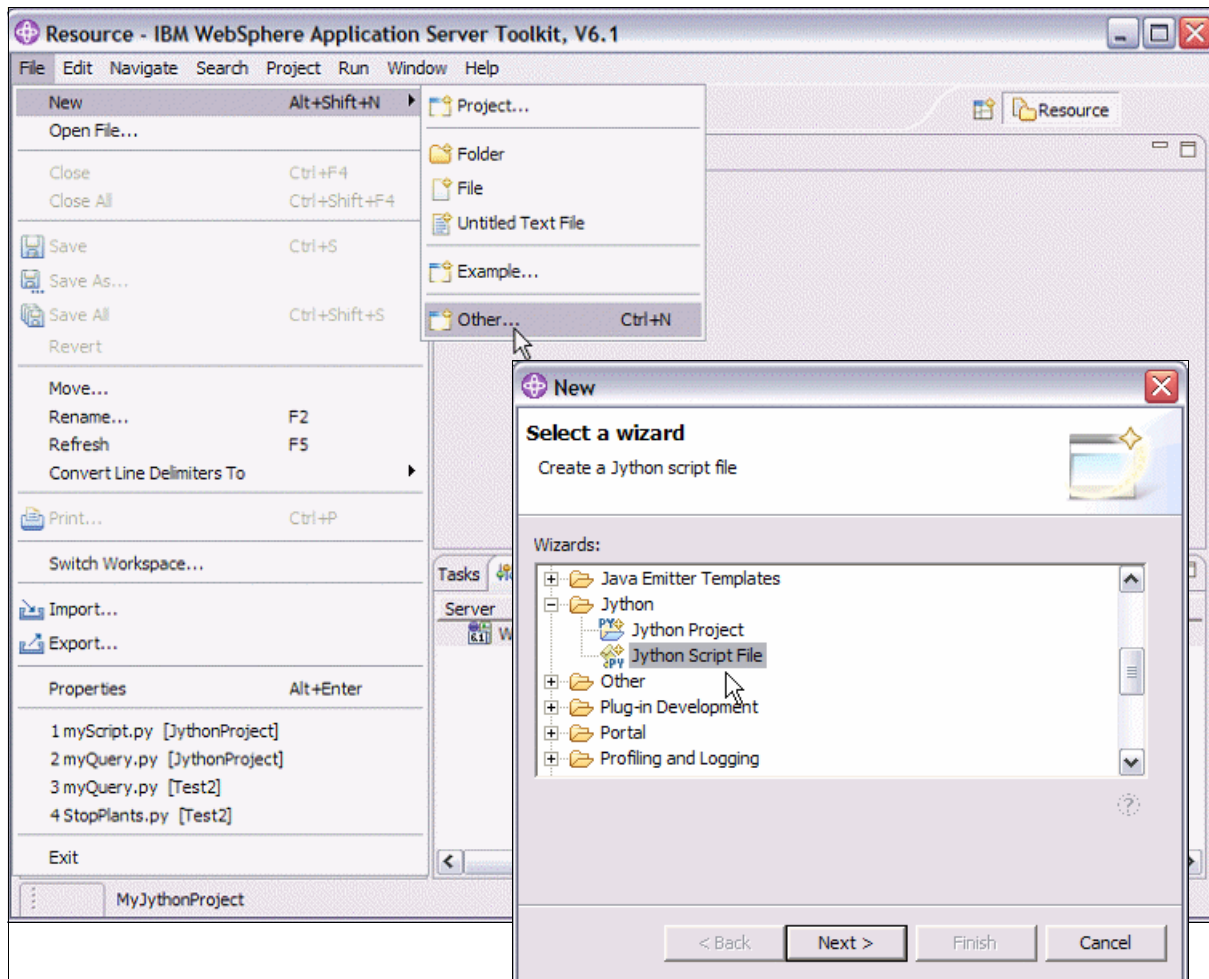

Figure 7-9 Create Jython Script File Wizard

- Expand the Jython folder, and select **Jython Script File**. Click **Next**.

3. In the Parent folder field (Figure 7-10), specify the path of an existing project folder in the current workspace where you want to store the new Jython script file, for example, if you specify the path as /MyJythonProject, the Jython script file is created in the Navigator view under the project called: MyJythonProject. You must specify a project folder that already exists in the workspace.
4. In the File name field, type a name for your new Jython script file. The file extension must be `.py` or `.jy`.

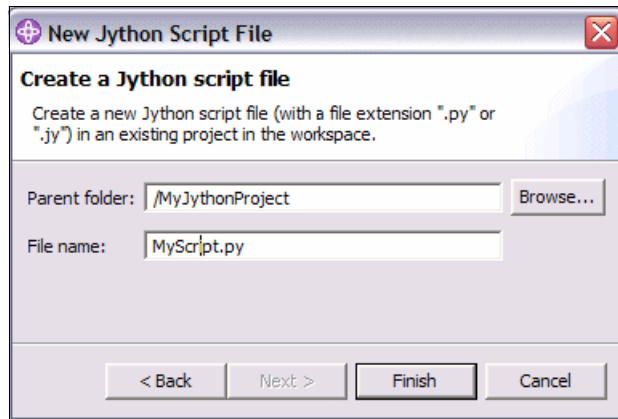

Figure 7-10 Create Jython Script file

5. Click **Finish** to create the Jython script file.

The Jython script file appears in the Navigator view and, by default, automatically opens in the Jython editor.

## 7.4.5 Generating WebSphere administrative commands to assist in developing Jython scripts

Use the WebSphere administration command assist tool to generate WebSphere administrative (`wsadmin`) commands for the Jython scripting language as you interact with the WebSphere Administrative Console. When you perform server operations in the WebSphere Administrative Console, the WebSphere Administration Command assist tool captures and displays the `wsadmin` commands that are issued. You can transfer the output from the WebSphere administration command view directly to a text editor, such as the Jython editor, which enables you to develop Jython scripts based on actual console actions.

**Restriction:** For the following operations, you must start WebSphere Application Server so that you can interact with the WebSphere Administrative Console.

To generate `wsadmin` commands as you interact with the WebSphere Administrative console:

1. Enable the command assistance notification option in the WebSphere Administrative Console:
  - a. Open the workbench of the WebSphere Application Server Toolkit. See 7.4.1, “Starting the WebSphere Application Server Toolkit (AST)” on page 224.
  - b. In the Servers view (see section 7.4.2, “Creating a server connection” on page 225), right-click the **server**, and select **Run administrative console**, as shown in Figure 7-11 on page 232.

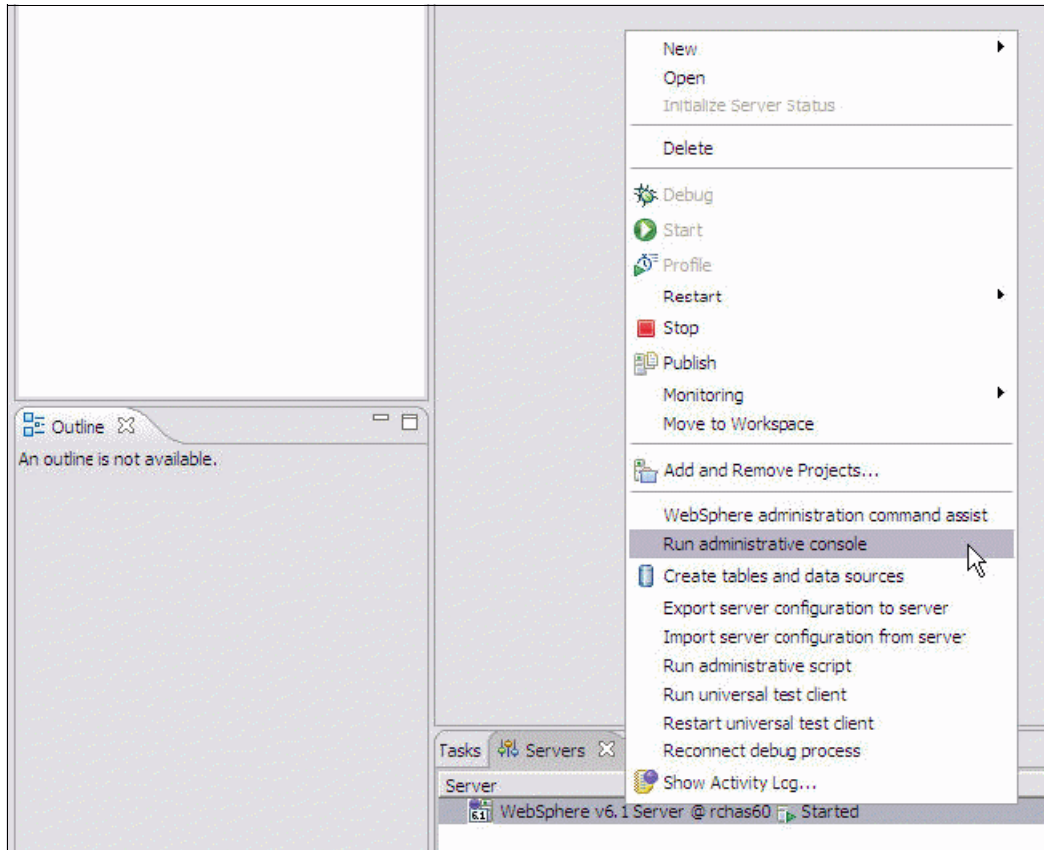

Figure 7-11 Opening the WebSphere Administrative Console from AST

- c. The Administrative Client logon window opens in the Web Browser view. Specify the user ID. If the server is secured, specify the password to access the administration console. If the server is not secured, you can specify any text for the user ID because it is used solely for logging purposes in that scenario. Click the **Log in** button.
- d. On the left-pane, expand and select **Applications** → **Enterprise Applications**.
- e. Scroll to the right of the Enterprise Application page, and under the Command Assistance section, click the **View administrative scripting command for last action** link, as shown in Figure 7-12 on page 233.

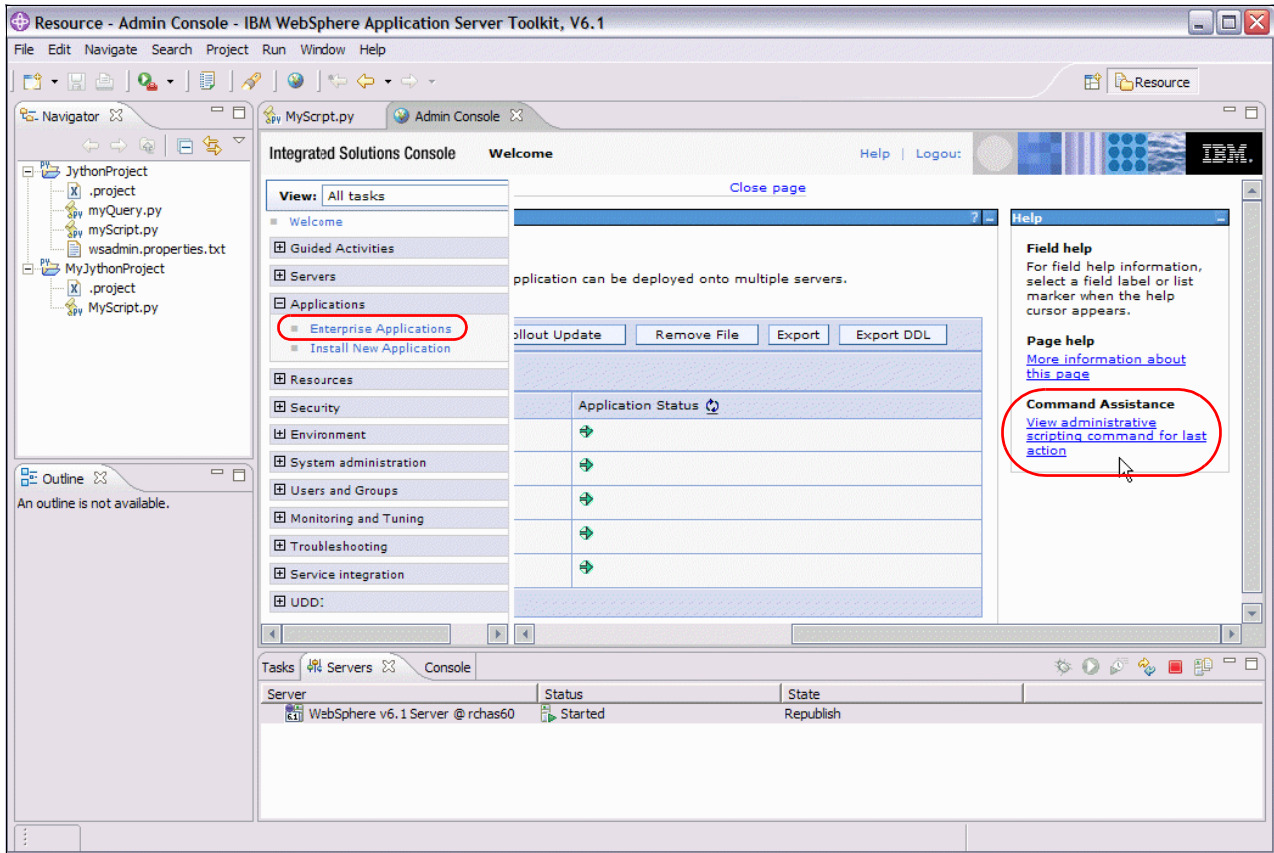

Figure 7-12 Command Assistance

- f. Administrative Scripting Commands open in a Web Browser window. Expand **Preferences**. See Figure 7-13.
- g. Select the **Enable command assistance notifications** option. Click **Apply**.

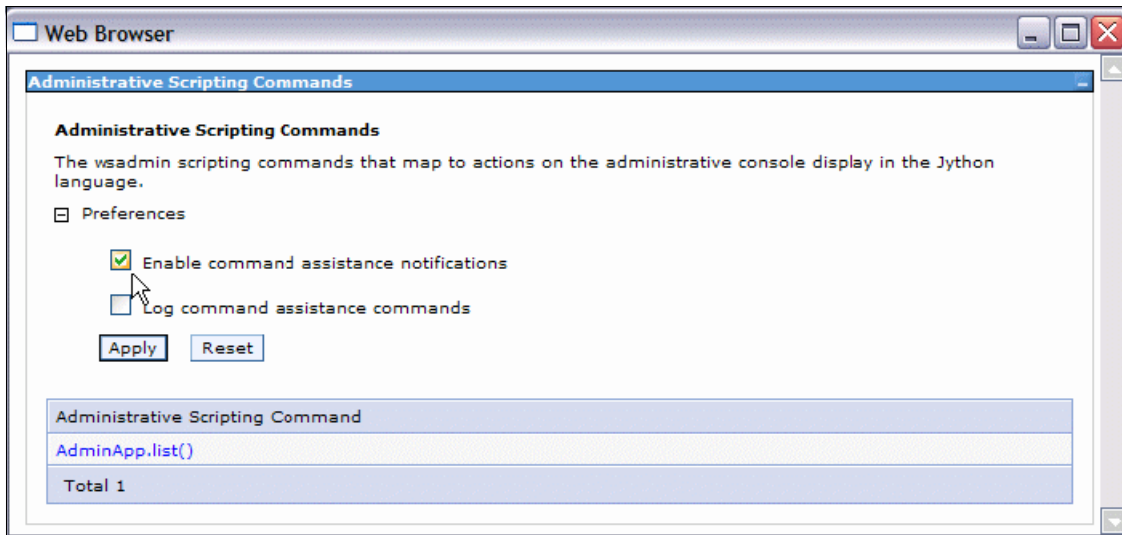

Figure 7-13 Command Assistance notifications

2. In the Servers view of the Workbench, right-click the server, and select **WebSphere administration command assist** as shown in Figure 7-14.

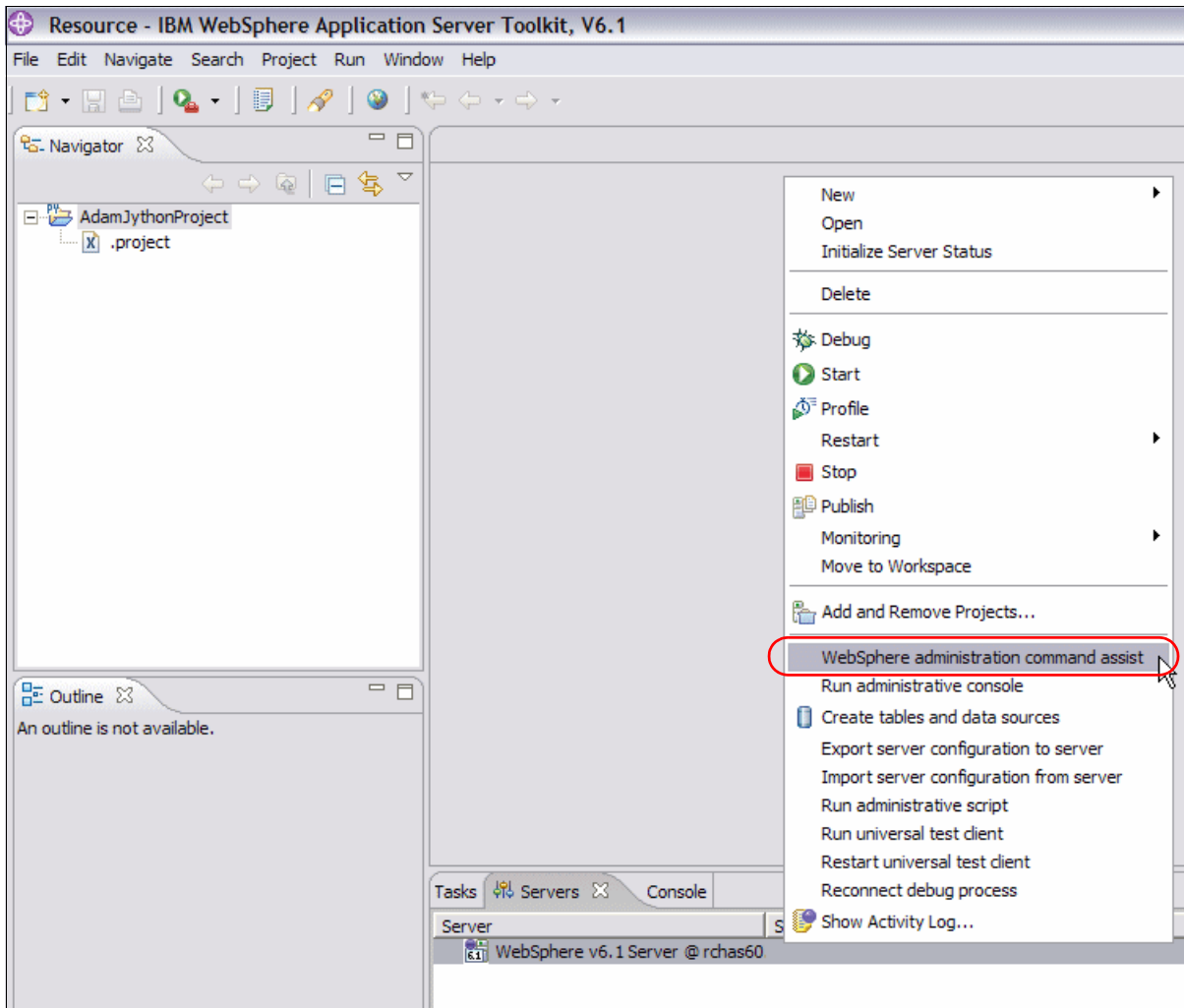

Figure 7-14 Selecting WebSphere administration command assist in AST

The WebSphere Administration Command view opens in the lower pane below the Integrated Solutions Console, as shown in Figure 7-15 on page 235.

3. In the **Select Server to Monitor** pull-down list, specify with a check mark the servers that you want the tool to monitor as you interact with its Administrative console. The Select Server to Monitor list is available in the toolbar of the WebSphere Administration Command view. (See Figure 7-15 on page 235).

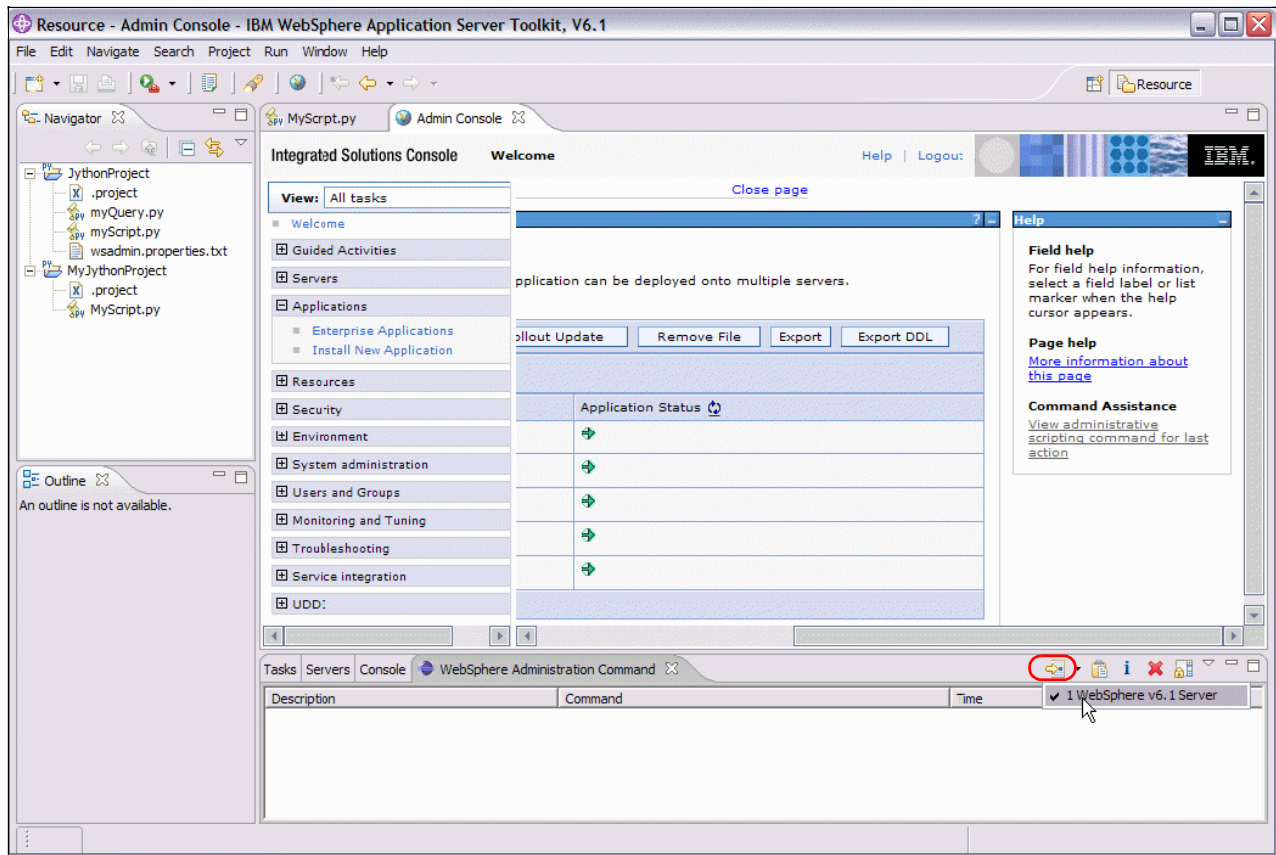

Figure 7-15 Select Server to Monitor

4. Perform your server operations in the administrative console. As you interact with the administrative console, the WebSphere Administration command view is populated with **wsadmin** commands for Jython.

**Tip:** If you want to see the **wsadmin** object, method, and the actual values pass into the parameter when the command is issued, select and hover the command in the WebSphere Administration Command view. A floating window appears that contains the documentation for the **wsadmin** method.

If you want to see additional help documentation on a **wsadmin** object, right-click the command in the WebSphere Administration Command view, and select **wsadmin Command Help** (or in the toolbar click the **View Online Help** button). The browser displays the **wsadmin** object documentation for the selected command. The documentation is provided by the WebSphere Information Center.

5. To transfer the **wsadmin** commands, which are generated in the WebSphere Administration Command view, to the Jython script:
  - a. Open the Jython script where you want to insert the generated **wsadmin** commands.
  - b. In the text editor, place the cursor to the position where you want to insert the generated **wsadmin** command.
  - c. In the WebSphere Administration Command, right-click the command, and select **Insert**. You can select multiple commands to transfer by using the SHIFT + Arrow key combination. (See Figure 7-16 on page 236).

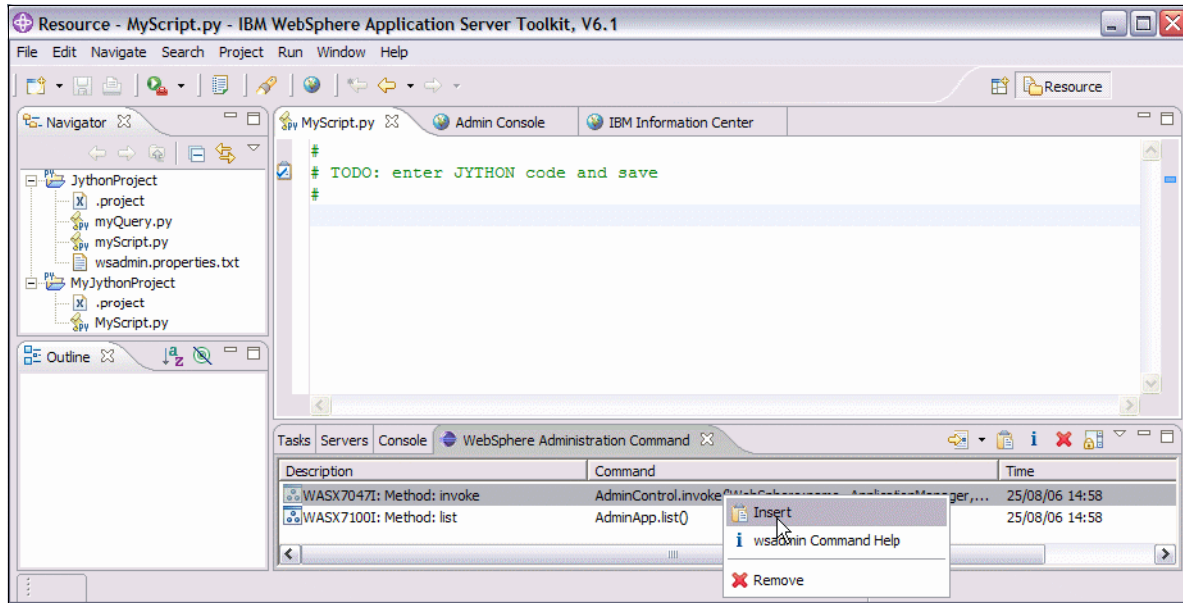

Figure 7-16 Insert Jython command

## 7.4.6 Getting content assistance and tips in the Jython editor

In the Jython editor, use content assist and content tips to speed up the creation of WebSphere Administrative (wsadmin) objects, methods and parameters, and Jython syntax.

You can use content assist to help you finish a line of code in the Jython editor. The placement of the cursor in your script file provides the context for the content assist to offer a list of suggested completion.

You can use content tips to see a list of parameter hints in a method argument. If the cursor is located at the parameter specification for a method reference, this actions shows a floating window with parameter types information.

To use content assist and tips in the Jython editor:

1. Open a Jython script file in the Jython editor.
2. Place your cursor in a partially-complete line of code in the Jython editor, right-click, select **Content Assist** (or press Ctrl-Space).
3. If the Jython editor finds valid candidates for this position, a list of possible completions is shown in a floating window. You can type further to narrow the list.
4. Use the arrow keys or the mouse pointer to navigate through the possible completions.
5. Select an item in the list to complete the code fragment.
6. If you place your cursor in a parameter specification for a method reference and right-click, you can select **Content Tip** (or press Ctrl-Shift-Space).
7. If the Jython editor finds valid candidates for this position, a list of parameter hints is shown in a floating box.

## 7.4.7 Migrating administrative Jacl scripts to Jython

The IBM Jacl to Jython Conversion Assistant (Jacl2Jython) is a program that assists in converting wsadmin scripts that are written in Jacl into Jython syntax. In most cases, the

results of the conversions are syntactically equivalent and usually runtime equivalent. However, the differences in the Jacl and Jython scripting languages might result in a few lines of script that are difficult to convert automatically by the Jacl2Jython program. In most of these cases, these converted lines of script are flagged `#!PROBLEM?` to mark areas in the script where you need to manually verify or alter the script to ensure that the intended runtime results are maintained. Although you need to manually review and verify all the converted script, the `#!PROBLEM?` flags help to identify areas in the script that most likely require further processing.

To run the Jacl2Jython program to convert Jacl to Jython syntax:

1. From a command prompt on your workstation, change to the `<AST_install_dir>/bin` directory, where `<AST_install_dir>` is the installation directory of the workbench. For a default installation, the directory is:  

```
C:\Program Files\IBM\WebSphere\AST\bin
```
2. Enter the command `Jacl2Jython input_Jacl_script_filename`. Where `input_Jacl_script_name` is the fully-qualified name of the Jacl script that you want to convert into a Jython script, for example, `C:\scripts\MyScript.jacl`.
3. If the Jacl2Jython program stops, it is because a parse error was encountered in the input Jacl script. As a result, a matching Jython script cannot be created. You need to resolve all the parse errors in the input Jacl script file. Then run the Jacl2Jython program again to continue with the conversion.

**Attention:** When the Jacl2Jython program encounters a problem parsing the input Jacl script file, it stops with a parse error message that contains the following information:

- ▶ The fully qualified name of the problematic script.
- ▶ The line and column number of where the parse error might be occurring.
- ▶ The cause of the parse error.
- ▶ The list of expected Jacl syntax that should have followed prior to reaching the problematic syntax.

4. If the Jacl2Jython program successfully parses the input Jacl script, then a matching Jython script file with a file extension `.py` is produced in the same directory as the input Jacl script.
5. Repeat the above steps again to run the Jacl2Jython program again, which ensures that all user method definitions are processed and recorded in the `Jacl2Jython_UserMethods.txt` file. This step helps resolve any unnecessary unknown command warnings and ensures that the converted Jython script is as clean as possible.
6. In a Jython editor or a text editor, open the Jython file that is produced by the Jacl2Jython program.
7. Find and fix any lines of script that are marked with a `#!PROBLEM?` comment flag. The Jacl2Jython program adds a `#!PROBLEM?` comment flag to the output of the Jython script when it detects a problem in the conversion.
8. Complete the line-by-line manual review and verification of the conversion. Manually convert or modify the script to function as originally intended.

## 7.4.8 Exporting Jython scripts

After you write a Jython script using the WebSphere Application Server Toolkit, you need to export it to the System i server so that you can run the script. For information about how to run the script file after export, refer to 7.2.1, “Running wsadmin script files” on page 222.

To export the Jython script file:

1. Map a network drive on your development workstation to an IFS share on the server, for example /root.
2. Right-click the script file in the Navigator view, as shown in Figure 7-17.
3. Select the **Export** option.

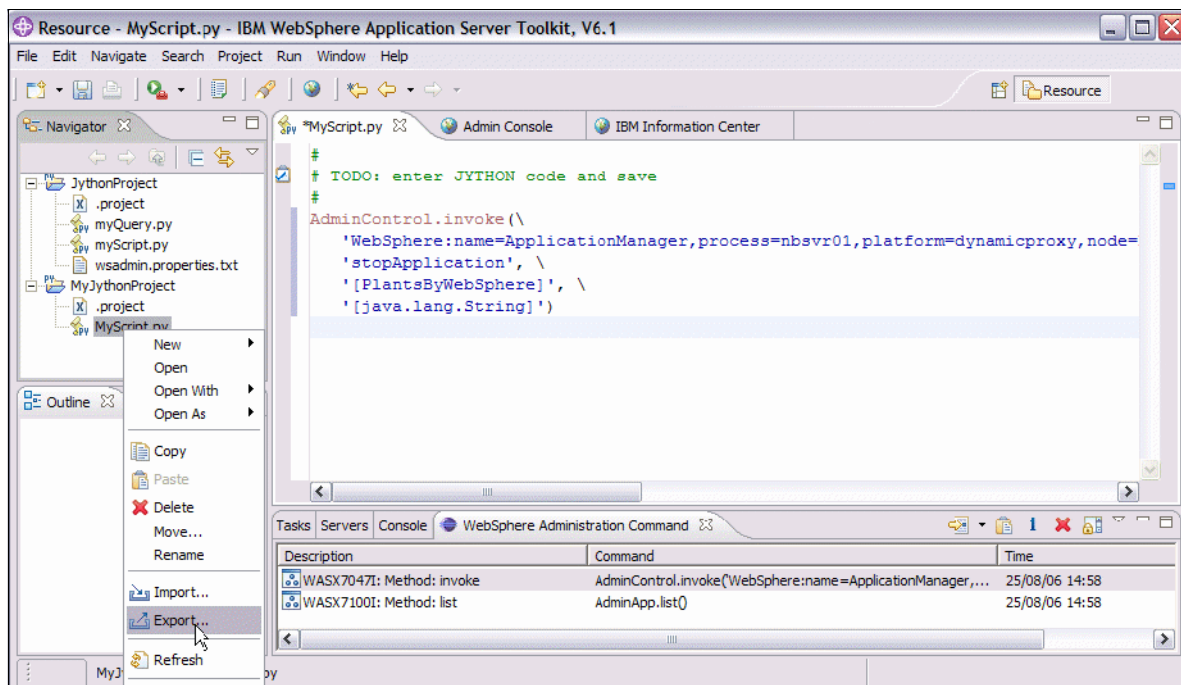

Figure 7-17 Export Jython file

4. Select **File system** in the Select dialog (Figure 7-18 on page 239). Click **Next**.
5. Specify a target directory to which to export your Jython script. Click **Finish**.

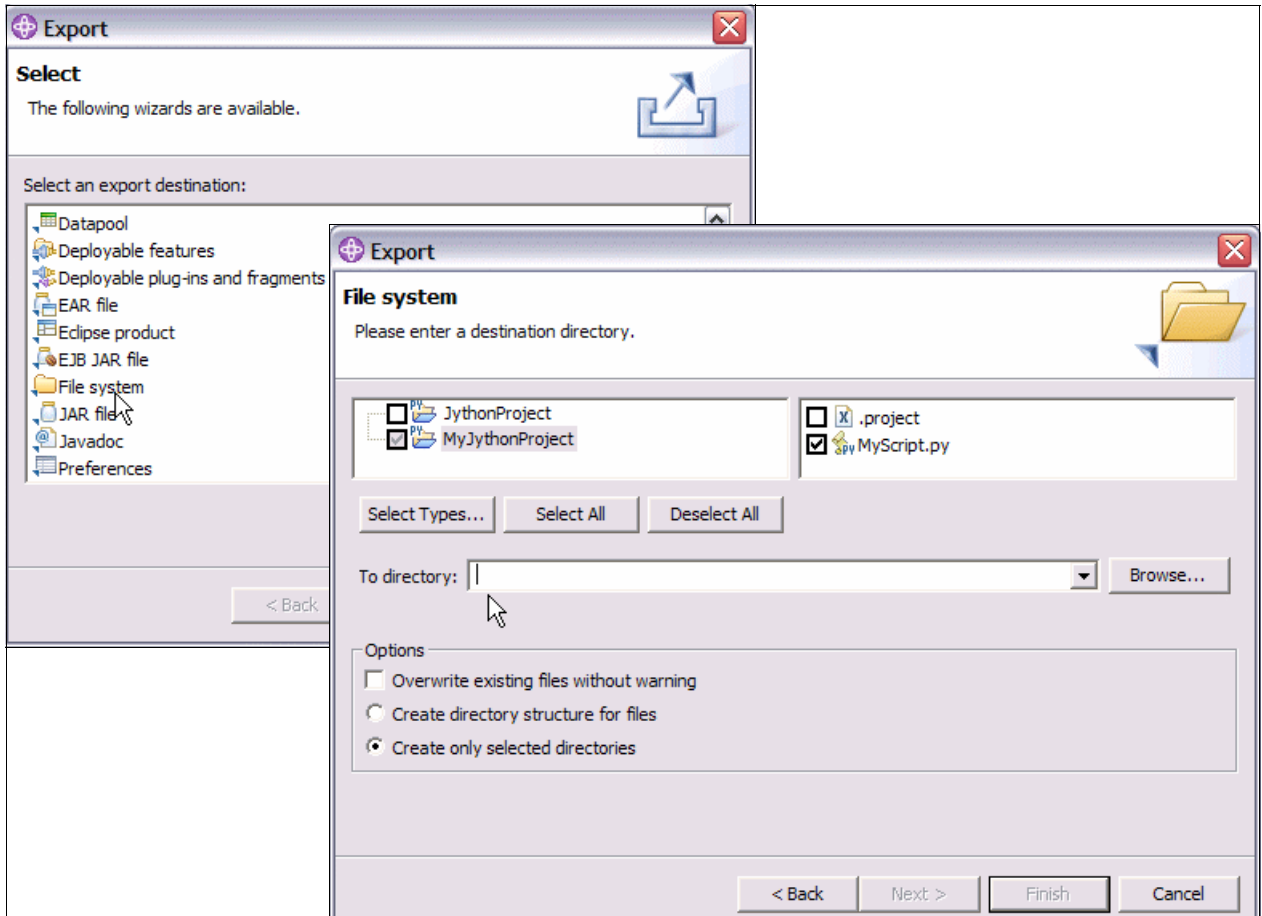

Figure 7-18 Export Jython file directory





## Turning on security

In this chapter, we describe the steps to set up different areas of security in WebSphere Application Server V6.1 for i5/OS. We discuss:

- ▶ Administrative security
- ▶ Secure SSL communication between HTTP Server and WebSphere Application Server
- ▶ Secure SSL communication between Web Browser and HTTP Server

We do not talk about security strategies or about security methods. We also do not cover platform independent WebSphere Application Server security aspects.

For information about security fundamentals, refer to *WebSphere Security Fundamentals*, REDP-3944 at:

<http://www.redbooks.ibm.com/redpapers/pdfs/redp3944.pdf>

The IBM Redbooks publication *IBM WebSphere Application Server V6.1 Security Handbook*, SG24-6316 is a more comprehensive publication on all aspects of WebSphere Application Server security.

Most WebSphere Application Server security functionality is platform independent; however, in this chapter we cover some examples from an i5/OS perspective, such as using the Digital Certificate Manager (DCM) to enable SSL.

**Important:** In the example shown in this chapter, we used a “clean” system with no prior security configuration. If you partially configured Web security on your system, skip the instructions for configuring those security parameters.

## 8.1 Administrative security

In previous releases of WebSphere Application Server, enabling Global Security activated security for both administration and applications. In WebSphere Application Server V6.1, Global Security is split into administrative and application security, each of which you can enable separately. However, for application security to take effect, administrative security must be enabled.

In WebSphere Application Server V6.1, there is a new feature that lets you enable administrative security out-of-the-box. The advantage of this is that at installation time, WebSphere Application Server administrators now have an easy way to restrict unauthorized access to a production server and administrative tasks. In the past, the WebSphere Application Server security administrator was required to perform post-installation configuration steps to secure the system. With the introduction of this feature, however, administrators can now set up the default security settings without the complexities of post-installation configuration. Out-of-the-box security is available from the installation wizard or from the profile management wizard. The following tasks are automatically performed at installation time if out-of-the-box administrative security is enabled:

- ▶ Administrative security is turned on
- ▶ Application security is disabled
- ▶ LTPA is set as the default authentication mechanism
- ▶ A server ID required for inter-process communication is automatically generated
- ▶ A built-in file-based user repository is configured and used as the default user repository. The built-in repository is a new feature made possible through the integration of *Virtual Member Manager* (VMM) with WebSphere Application Server. This means you can then use the user and group management features that are provided by VMM to add additional users.

For detailed information about Administrative security, see Chapter 3 of the IBM Redbooks publication *IBM WebSphere Application Server V6.1 Security Handbook*, SG24-6316.

### 8.1.1 Enabling administrative security after installation

By default, administrative security is enabled as part of the installation process (for details see 3.4, “Performing WebSphere Application Server installation” on page 38). If you unchecked the option to enable administrative security during the installation process, we recommend that you now enable it.

See Chapter 3 of the IBM Redbooks publication *IBM WebSphere Application Server V6.1 Security Handbook*, SG24-6316, for a detailed description of enabling administrative security.

There are two ways to enable administrative security for WebSphere Application Server post-installation:

1. From the i5/OS command line:
  - a. Sign on to the i5/OS with a user ID and password.

**Note:** The user profile needs to have \*ALLOBJ and \*SECADM special authorities.

- b. Enter STRQSH on the CL command line to start Qshell.

- c. At the Qshell prompt, run these command (we use Base edition installed at the default location):

```
cd /QIBM/ProdData/WebSphere/AppServer/V61/Base/bin
```

- d. Start the WebSphere Application Server before you enable the administrative security, where <profile\_name> is the name of your profile that you want to secure:

```
startserver -profileName <profile_name>
```

- e. Invoke the **wsadmin** command to use the wsadmin tool:

```
wsadmin
```

In this example, we use the default scripting language - Jacl. For more information about the wsadmin tool, see 7.2, "Invoking wsadmin" on page 220.

Figure 8-1 shows an example of the output.

```
wsadmin
WASX7209I: Connected to process "server1" on node RCHAS60 using SOAP
connector; The type of process is: UnManagedProcess
WASX7029I: For help, enter: "$Help help"
wsadmin>
```

*Figure 8-1 wsadmin enable administrative security*

- f. Check if the global security is turned on by running the command:

```
$AdminTask isGlobalSecurityEnabled
```

If it returns false, you need to enable security.

- g. Run the following command to enable administrative security, where <user> and <password> are credentials for an i5/OS user profile:

```
securityon <user> <password>
```

Figure 8-2 on page 244 shows an example of the output.

```

securityon lclwas lclpwd
Done with LOCAL OS security turning on process, now you need to restart
server1 to make it affected.
Then you can start using the client with SOAP or RMI connector.

If you are using SOAP Connector to connect to the server, you need to modify
soap.client.propsfileinyour<install_root>/propetiesdirectory.
Update as below for SOAP connector:
com.ibm.SOAP.securityEnabled=true
com.ibm.SOAP.loginUserid=lclwas
com.ibm.SOAP.loginPassword=lclpwd

If you are using RMI Connector to connect to the server, you will be prompted
to enter the "userid" and the "password". If you want to by pass the login
process, you can modify sas.client.props file in your <install_root>/properties
directory.

Update as below for RMI connector:
com.ibm.CORBA.loginSource=properties
com.ibm.CORBA.loginUserid=lclwas
com.ibm.CORBA.loginPassword=lclpwd

```

Figure 8-2 Running the securityon command

- h. Exit the wsadmin tool by issuing the **quit** command.
- i. Restart WebSphere Application Server to activate the administrative security. See 4.2, "Day-to-day administration" on page 88 for information about how to restart WebSphere Application Server.
- j. Access the WebSphere Administrative Console on the server by pointing a Web browser to:

`http://<your_server_hostname>:<port_number>/ibm/console`

Example:

`http://myServer.ibm.com:9060/ibm/console`

This link redirects you to the new address:

`https://myServer.ibm.com:9043/ibm/console/login.jsp`

You are presented with a new Welcome window (Figure 8-3) that asks for a User ID and Password.

Figure 8-3 Logging in to WebSphere Administrative Console

## 8.1.2 Disabling administrative security

There are two ways to disable administrative security:

1. Using the WebSphere Administrative Console:

The easiest way to disable administrative security is to use the WebSphere Administrative Console:

- a. Logon to the WebSphere Administrative Console.
- b. Click **Security** → **Secure administration, applications and infrastructure**.
- c. Uncheck the **Enable administrative security** box.
- d. Click **Apply** and **Save** your change.
- e. Restart your WebSphere Application Server.

To work, this procedure requires that the application server already be running. If, for some reason, you cannot start the application server, for example, because of an incorrectly-configured user repository, you can instead disable administrative security using the command line.

2. If you lost your user ID or password, you can disable administrative security from the command line:

- a. From the command line, sign on to the i5/OS with user ID and password.

**Note:** The user profile needs to have \*ALLOBJ and \*SECADM special authorities.

- b. Enter STRQSH on the CL command line to start Qshell.
- c. At the Qshell prompt, change to the product bin directory by issuing the command (we use Base edition installed at the default location):

```
cd /QIBM/ProdData/WebSphere/AppServer/V61/Base/bin
```

- d. Invoke the **wsadmin** command to use the wsadmin tool:

```
wsadmin -profileName <profile_name> -conntype NONE
```

Figure 8-4 shows an example of the output.

```
$  
wsadmin -profileName default -conntype NONE  
WASX7357I: By request, this scripting client is not connected to any server  
process. Certain configuration and application operations will be available in  
local mode.  
WASX7029I: For help, enter: "$Help help"  
wsadmin>
```

Figure 8-4 Starting wsadmin with -conntype NONE option

- e. At the **wsadmin** command prompt, type the **securityoff** command, and press Enter to disable administrative security:

Figure 8-5 on page 246 shows an example of the output.

```

wsadmin>
> securityoff
LOCAL OS security is off now but you need to restart server1 to make it
affected.
wsadmin>
> quit

```

Figure 8-5 Using `securityoff` `wsadmin` command to disable administrative security

- f. Exit the `wsadmin` tool by issuing the `quit` command at the `wsadmin` command prompt. Press Enter.

- g. Start the WebSphere Application Server instance:

- i. Start a QShell session with the `STRQSH` command.
- ii. Change to the core binary product files location. For an installation in the default location, the command is:

```
cd /QIBM/ProdData/WebSphere/AppServer/V61/Base/bin
```

- iii. Run the `startServer` script, and supply the profile name:

```
startServer -profileName <profile_name>
```

**Tip:** To activate the change you need to start/restart your server. If restarting the server, you need the user ID and password in order to stop it first. However if you lose your password the `stopServer` command will not work; you need a different way to stop your active server. You can stop the server from `WRKACTJOB` with option 4. Give the server sufficient time to stop in a controlled fashion before restarting.

- h. Start the WebSphere Administrative Console by pointing a Web browser at:

```
http://<your_server_hostname>:9060/ibm/console/logon.jsp
```

You will notice the Welcome window (Figure 8-6) now only asks for a User ID.

Figure 8-6 Logon panel for WebSphere administrative console

## 8.2 Enabling SSL

The Secure Sockets Layer (SSL) protocol provides transport layer security, which allows for secure communication between a client and the application server. The SSL configuration options in WebSphere Application Server offer full end-to-end management, which includes certificate management, individual endpoint SSL mappings, and scoped association of SSL configurations and key stores.

For a detailed description about configuring SSL in WebSphere Application Server, see Chapter 4 of the IBM Redbooks publication *IBM WebSphere Application Server V6.1 Security Handbook*, SG24-6316.

In this chapter, we provide step-by-step instructions for two common tasks that are associated with SSL:

- ▶ Configuring SSL between the HTTP server and WebSphere Application Server.
- ▶ Configuring SSL between the Web browser (Client) and the HTTP server.

Figure 8-7 shows how the system is configured to use SSL *end-to-end* after you perform the two tasks.

Configuring SSL between the HTTP server and WebSphere Application Server is something that not everyone deems necessary to perform. You may have chosen a topology that uses firewalls and other security measures that isolate the traffic between the HTTP server and WebSphere Application Server sufficiently for your needs, without the additional overhead that is associated with setting up and maintaining SSL-encrypted communications.

However, configuring SSL between the Web browser and the HTTP server is a task that we anticipate a significant proportion of you might need to perform to provide a known level of security and reassurance to users. This need varies by application, but for applications, such as internet banking and e-commerce, SSL security between the Web browser and the HTTP server is a must.

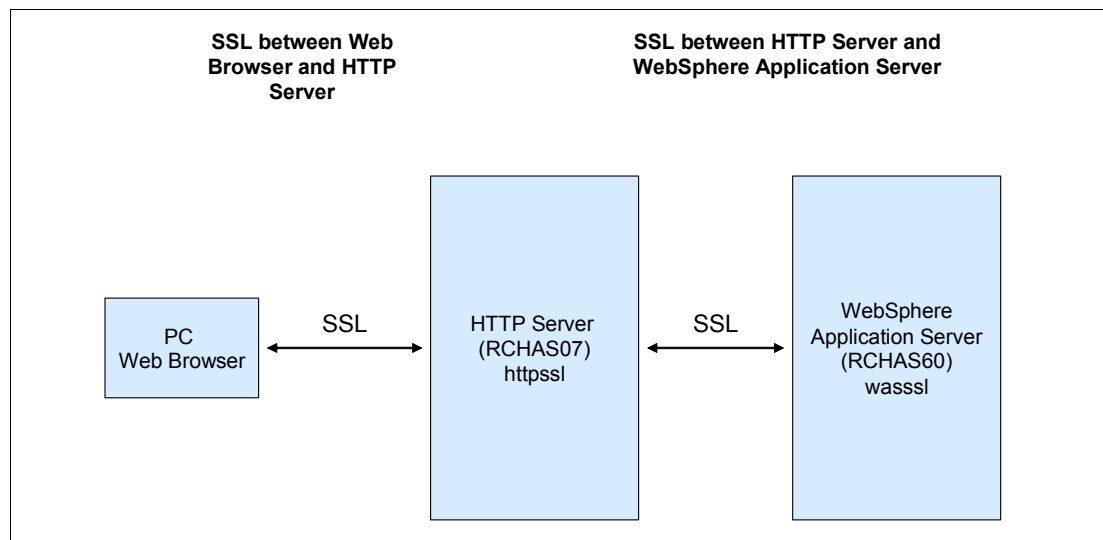

Figure 8-7 System configuration after enabling SSL

## 8.2.1 Overview of the sample environment

For this example, we used two System i servers to demonstrate how to create a secure connection between a Web server and WebSphere Application Server. Both systems are running i5/OS V5R4M0, and there is no firewall established between them. WebSphere Application Server V6.1 is installed on each system at the default installation path:

```
/QIBM/ProdData/WebSphere/AppServer/V61/Base/bin
```

- ▶ WebSphere Application Server: System A (RCHAS60)
  - WebSphere Application Server profile name: wasssl
  - WebSphere Application Server starting port block: 52400
- ▶ IBM HTTP Server for i5/OS: System B (RCHAS07)
  - HTTP server profile name: httpssl
  - HTTP port: 52480

**Tip:** When you create an SSL connection between two systems or LPARs for the first time, we recommend that you do it without a firewall for simpler configuration. After you test your SSL connection successfully, establish the firewall so that it is easier to locate any problems that may occur.

## 8.3 Configuring SSL between a Web server and WebSphere Application Server

Secure transport between a remote Web server and an application server is often required. New support for digital certificate management in WebSphere Application Server V6.1 greatly simplifies digital certificate management; however, some additional configuration is required on System i5/OS to enable secure transport.

In this section, we provide step-by-step instructions for creating a secure connection between a Web server and WebSphere Application Server, as shown in Figure 8-8.

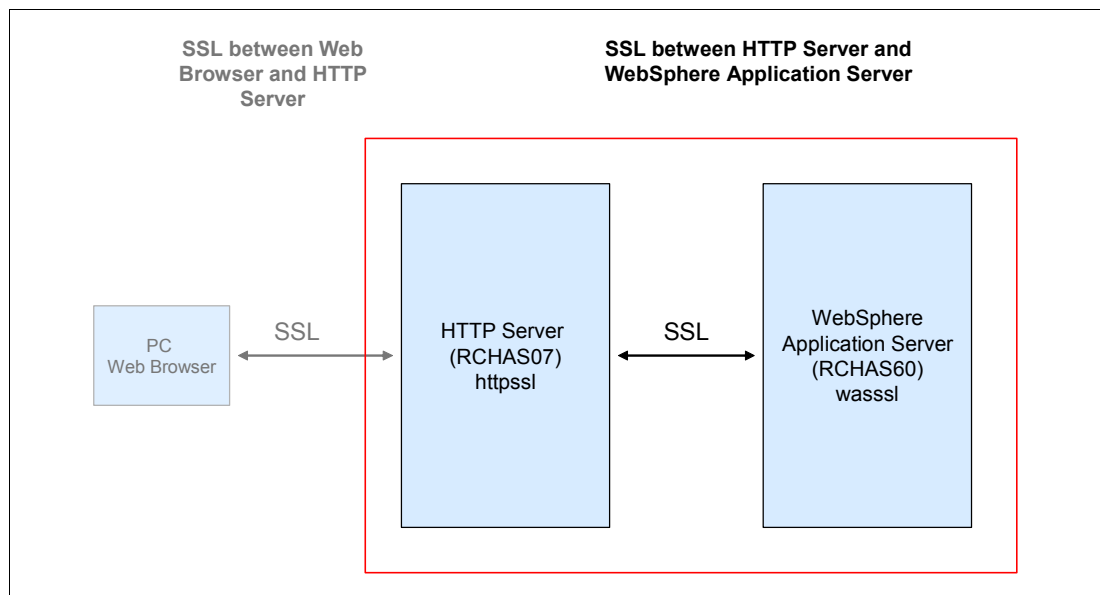

Figure 8-8 Configuring SSL between a Web server and WebSphere Application Server systems

In our example, we use two System i servers, both have i5/OS V5R4M0 installed. For simplicity, during initial configuration, there is no firewall established between the servers. We outlined the broad tasks that we perform; consequently, before we provide detailed instructions for each task:

**Note:** In the remainder of this chapter, we sometimes refer to the application server system as the *WAS system*, and the remote Web server as the *HTTP system*.

1. Create an application server profile on the WebSphere Application Server system.
2. Create an HTTP WebSphere profile on the remote Web server system.
3. Create an IBM HTTP server instance on the HTTP system and associate this with the HTTP WebSphere server profile.
4. Create the Web server definition on the WAS system.
5. Add the user profile and password, for administering the HTTP server installation, to the Web server definition.
6. Create a virtual host alias for the remote Web server.
7. Regenerate and propagate the Web server plug-in configuration file.
8. Check messages in `http_plugin.log` for any errors.
9. Perform additional configuration required for the Web server plug-in.
10. Enable the secure transport between the Web server and the application server systems.
11. Verify that the secure transport is working.

**Note:** You may have already performed some of these configuration tasks, such as creating profiles for the application server and Web server and performing the association between the application server and the Web server. Therefore you can skip to 8.3.8, “Verifying the configuration” on page 258 and proceed after you verify that you have a working “non-SSL” configuration.

### 8.3.1 Creating an application server profile on WebSphere Application Server system

Perform the following steps to create a stand-alone WebSphere profile:

1. Sign on to your WebSphere Application Server i5/OS system (RCHAS60 in our example).
2. Start a QShell session with the STRQSH command.
3. Change the directory to the WebSphere Application Server V6.1 product bin directory by issuing the command:

```
cd /QIBM/ProdData/WebSphere/AppServer/V61/Base/bin
```

4. Create a WebSphere Application Server profile using the `manageprofiles` script. Refer to 4.2, “Day-to-day administration” on page 88 for more information about the `manageprofiles` script. We used the following command for our scenario:

```
manageprofiles -create -profileName wasss1 -startingPort 52400
```

Figure 8-9 on page 250 shows an example of the output from the above command.

```

> cd /QIBM/ProdData/WebSphere/AppServer/V61/Base/bin
$
>manageprofiles -create -profileName wasssl -startingPort 52400
INSTCONFSUCCESS: Success: Profile wasssl now exists. Please consult
/QIBM/UserData/WebSphere/AppServer/V61/Base/profiles/wasssl/logs/AboutThisProfile.txt for more information about this profile.

```

Figure 8-9 Create WebSphere Application Server profile wasssl on system A

### 8.3.2 Creating an HTTP WebSphere profile on the remote Web server system

Perform the following steps on the HTTP Server system (RCHAS07 in our example):

1. Sign on to your remote Web server i5/OS system.
2. Start a QShell session with the STRQSH command.
3. Change the directory to the WebSphere Application Server V6.1 product bin directory by issuing the command:

```
cd /QIBM/ProdData/WebSphere/AppServer/V61/Base/bin
```

**Tip:** You do not need to install a full WebSphere Application Server product; instead, just install the Web server plug-in on the HTTP Server system. See 5.3, “Configuring a remote Web server with WebSphere Application Server” on page 171.

4. Create an HTTP server profile using the manageprofiles script. Refer to 4.2, “Day-to-day administration” on page 88, for more information about the manageprofiles script. We used the following command for our scenario:

```
manageprofiles -create -profileName httpssl -templatePath http
```

Figure 8-10 shows an example of the output from the **manageprofiles** command.

```

> cd /QIBM/ProdData/WebSphere/AppServer/V61/Base/bin
$>manageprofiles -create -profileName httpssl -templatePath http
INSTCONFSUCCESS: Success: Profile httpssl now exists. Please consult
/QIBM/UserData/WebSphere/AppServer/V61/Base/profiles/httpssl
/logs/AboutThisProfile.txt for more information about this profile.

```

Figure 8-10 Create HTTP profile httpssl on system B

### 8.3.3 Creating an IBM HTTP server instance on the remote Web server and associating it with the HTTP server profile

Use the following steps to create and configure an HTTP Server instance (on RCHAS07 in our example):

1. Launch i5/OS tasks by pointing your Web browser at the following URL:  
`http://<HTTP_system_hostname>:2001`
2. Log in using your i5/OS user profile and password, and select **IBM Web Administration for i5/OS**.
3. Select the **Setup** tab.
4. Select **Create a New HTTP Server**.

5. Enter the Server name (we used https), and click **Next**, as shown in Figure 8-11.



**Create HTTP Server**

Welcome to the Create New HTTP Server wizard. This wizard helps you set up and create a new HTTP server

You must name your new server. This name will be used later to manage the server.

What do you want to name your new server?

Server name:

Server description:

Click **Next** to continue or **Cancel** to leave at anytime.

Figure 8-11 Create HTTP Server https

6. Click **Next** to accept the default server root.
7. Click **Next** to accept the default document root.
8. Enter the number of a free Port (we chose 52480), and click **Next**, as shown in Figure 8-12.

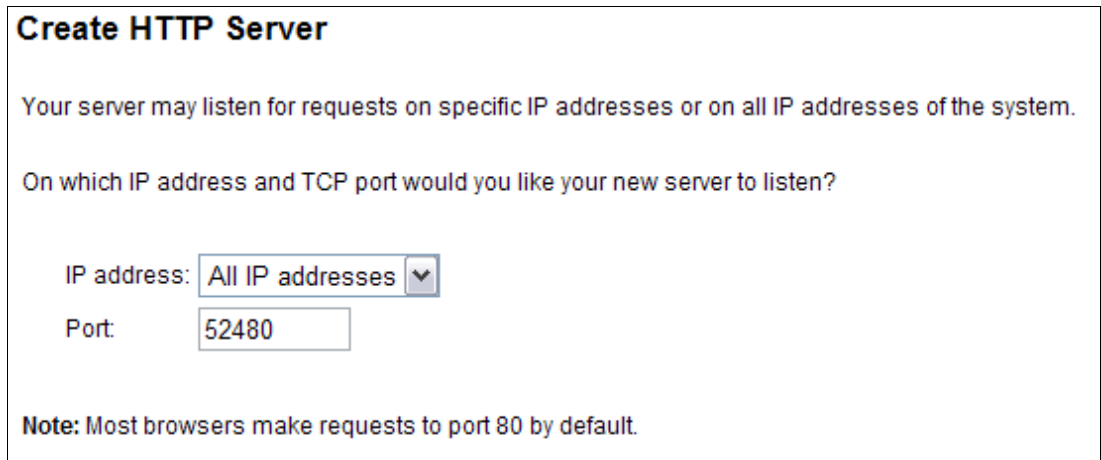

**Create HTTP Server**

Your server may listen for requests on specific IP addresses or on all IP addresses of the system.

On which IP address and TCP port would you like your new server to listen?

IP address:

Port:

**Note:** Most browsers make requests to port 80 by default.

Figure 8-12 Create HTTP Server https port

9. Select **No** to decline use of an access log, and click **Next**.
10. Click **Next** to accept the default log handling behavior.
11. Click **Finish** to create the HTTP server. Figure 8-13 on page 252 shows an example of the summary for the Web server instance that we created.

Create HTTP Server	
Server name:	HTTPSSL
Server description:	HTTP SSL server
Server root:	/www/httpssl
Document root:	/www/httpssl/htdocs
IP address:	All IP addresses
Port:	52480
Log directory:	/www/httpssl/logs
Access log file:	access_log
Error log file:	error_log
Log maintenance:	7 days

Figure 8-13 Create HTTP server summary

## Associating the Web server instance with the Web server profile

The next step is to link the IBM HTTP Server for i5/OS instance, which we just created, with the WebSphere profile, httpssl, which we created in the previous step:

1. Select the **Manage** tab in IBM Web Administration for i5/OS on the Web server system
2. Select the **HTTP Servers** tab.
3. Select server **HTTPSSL - Apache** from the pull-down list.
4. On the left panel, click **WebSphere Application Server**.
5. Select the WebSphere Application Server V6.1 product that you are using.
6. Select **httpssl** from the WebSphere profile pull-down list.
7. Select **All applications** for the installed applications to map to the Web server, and click **OK**. Figure 8-14 shows an example of performing the association.

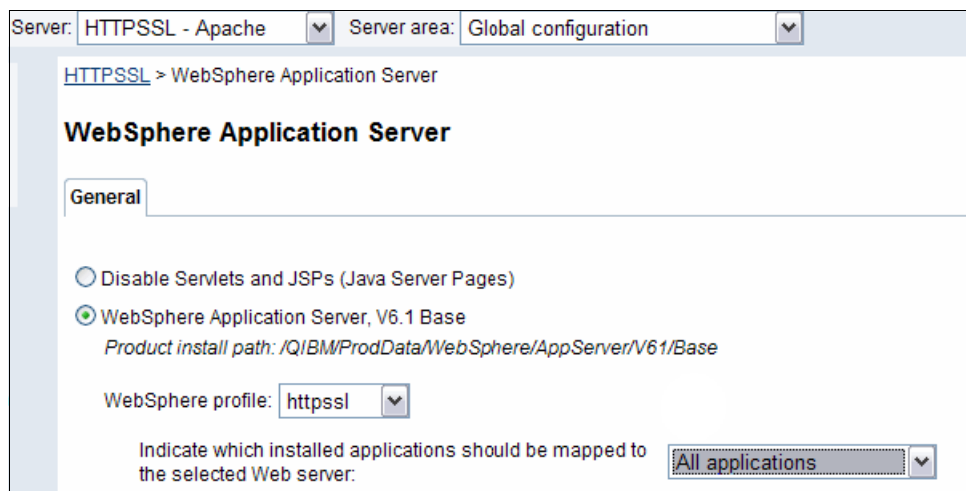

Figure 8-14 Connect http server to http profile httpssl

### 8.3.4 Creating the Web server definition on the application server system

In this section, you are required to copy a script from the Web server system (RCHAS07 in our example) to the application server system (RCHAS60 in our example). Use the iSeries Navigator to copy the files between the systems. See *Connecting to iSeries: iSeries Navigator* in the Information Center for details:

<http://publib.boulder.ibm.com/InfoCenter/iseriess/v5r4/index.jsp?topic=/rzahg/rzahginav.htm>

1. Copy the `configureIHS_HTTPSSL` script from the Web server system to the application server system. The script is located in the `<https1_profile_root>/config/IHS_HTTPSSL` directory. In our environment, the location is:

```
/QIBM/UserData/WebSphere/AppServer/V61/Base/profiles/https1/config/IHS_HTTPSSL
```

2. Place the file you copied in the previous step, into the `<wasssl_profile_root>/bin` directory on the application server system. In our environment, the location is:

```
/QIBM/UserData/WebSphere/AppServer/V61/Base/profiles/wasssl/bin/
```

3. On the application server system, start a Qshell session with the `STRQSH` command.
4. On the application server system, start the WebSphere Application Server profile (`wasssl` in our case) using the following two commands:

```
cd /QIBM/UserData/WebSphere/AppServer/V61/Base/profiles/wasssl/bin
startServer
```

wait for the message: Application server `wasssl` in profile `wasssl` has started and is ready to accept connections on admin port 52401, as shown in Figure 8-15 on page 254.

5. Run the script that you copied in the previous step by issuing the following command at the Qshell prompt:

```
./configureIHS_HTTPSSL
```

Figure 8-15 on page 254 shows an example of the output of running this script.

```

startServer
CPC1221: Job 174737/QEJBSVR/WASSSL submitted to job queue QWASJOBQ in
library QWAS61.
CWNATV00I: Application server wasssl in profile wasssl has started and is
ready to accept connections on admin port 52401.

./configureIHS_HTTPSSL
WASX7209I: Connected to process "wasssl" on node RCHAS60_wasssl using SOAP
connector; The type of process is: UnManagedProcess
WASX7303I: The following options are passed to the scripting environment and
are available as arguments that are stored in the argv variable: "[IHS_HTTPSSL,
IHS, /www/HTTPSSL, /www/HTTPSSL/conf/httpd.conf, 52480, MAP_ALL,
/QIBM/UserData/WebSphere/AppServer/V 61/Base/profiles/https1, unmanaged,
RCHAS07.ITSO.IBM.COM-node, RCHAS07.ITSO.IBM.COM, os400, 2001, NULL, NULL,
HTTPSSL]"

Input parameters:

Web server name          - IHS_HTTPSSL
Web server type          - IHS
Web server install location - /www/HTTPSSL
Web server config location - /www/HTTPSSL/conf/httpd.conf
Web server port          - 52480
Map Applications         - MAP_ALL
Plugin install location  -
/QIBM/UserData/WebSphere/AppServer/V61/Base/profiles/https1
Web server node type     - unmanaged
Web server node name     - RCHAS07.ITSO.IBM.COM-node
Web server host name     - RCHAS07.ITSO.IBM.COM
Web server operating system - os400
IHS Admin port          - 2001
IHS Admin user ID       - NULL
IHS Admin password      - NULL
IHS service name        - HTTPSSL

Processing the application query.
Get the current target mapping for the application query.
Computed the current target mapping for the application query.
Start updating the target mappings for the application query.
Target mapping is updated for the application query.

Start saving the configuration.

Configuration save is complete.
$

```

Figure 8-15 Run configureIHS\_HTTPSSL script

### 8.3.5 Adding the user profile and password for administering the HTTP server installation to the Web server definition

Configure the remote HTTP server administration using the following instructions:

1. Use your Web browser to open the WebSphere Administrative Console on the application server system by requesting the URL:

`http://<WAS_system_hostname>:port/ibm/console`

In our case the URL is:

`http://RCHAS60:52401/ibm/console/`

2. Login to the WebSphere Administrative Console.
3. Expand **Servers** → **Web servers**.
4. Click the HTTP Server instance that you previously created. In our case, this is **IHS\_HTTPSSL**. Figure 8-16 shows an example of the configuration settings of the HTTP Server instance.

The screenshot shows the configuration page for the IHS\_HTTPSSL web server instance. The page is titled "Web servers > IHS\_HTTPSSL" and includes a brief description: "Use this page to configure a Web server that provides HTTP and HTTPS support to application servers." The configuration is organized into two main sections: "General Properties" and "Additional Properties".

**General Properties:**

- Web server name: IHS\_HTTPSSL
- Type: IBM HTTP Server
- Host name: RCHAS07.RCHLAND.IBM.COM
- \* Port: 52480
- \* Web server installation location: /www/HTTPSSL
- \* Configuration file name: /www/HTTPSSL/conf/httpd.conf (with an "Edit" button)
- Web server Instance Name: HTTPSSL
- Platform Type: OS/400

**Additional Properties:**

- Log file
- Configuration File
- Plug-in properties
- Remote Web server management
- Custom properties

At the bottom of the page, there are four buttons: "Apply", "OK", "Reset", and "Cancel".

Figure 8-16 Configuration for Web server IHS\_HTTPSSL

5. Click **Remote Web server management**.

Enter the user ID and password (Figure 8-17 on page 256) that are required to authenticate with the HTTP Server instance on the Web server system (RCHAS07 in our example). The authorities required by this profile are the same as that required to access the HTTP administration GUI.

6. Click **OK** to save your configuration changes.

[Web servers](#) > [IHS HTTPS](#) > [Plug-in properties](#) > [Remote Web server management](#)

Use this page to configure the IBM(R) HTTP Server administration server for a Web server. These properties are required for a Web server that is not installed on the same machine as the WebSphere(R) Application server.

Configuration

---

**Remote Web server management**

\* Port

\* Username

\* Password

Figure 8-17 Remote authentication entry

### 8.3.6 Creating a virtual host alias for the remote Web server

Perform the following steps on the WebSphere Application Server system to create a virtual host alias for the remote Web server:

1. Expand **Environment** → **Virtual Hosts** in the WebSphere Administrative Console.
2. Click **default\_host**.
3. Click **Host Aliases**. The settings for the default\_host are displayed.
4. Click **New**. The General Properties are displayed.
5. Type the information for Host name and Port (Figure 8-18) for the Web server system (RCHAS07, port 52480 in our case).

[Virtual Hosts](#) > [default\\_host](#) > [Host Aliases](#) > [New](#)

Use this page to edit or create a domain name system (DNS) alias by which the virtual host is known. An alias is the combination of DNS host name and a unique port number. A Web client uses the alias to form the URL request of a Web application resource. Application resources include servlets, JSP files, or HTML pages. For example, the default\_host alias is the myhost.newyork.com:9080 portion of http://myhost.newyork.com:9080/servlet/snoop or the myhost.newyork.com:9043 portion of a secure http://myhost.newyork.com:9043/servlet/snoop URL.

Configuration

---

**General Properties**

\* Host Name

\* Port

Figure 8-18 Add virtual Host

6. Click **OK**, then click the **Save** link at the top of the page to save your configuration.
7. After you create a new Host Alias, you must regenerate the Web server plug-in configuration XML file:
  - a. Click **Servers** → **Web servers**.

- b. Select the check box next to your Web server profile (IHS\_HTTPSSL in our example).
- c. Click **Generate Plug-In**. Figure 8-19 shows an example of the output.

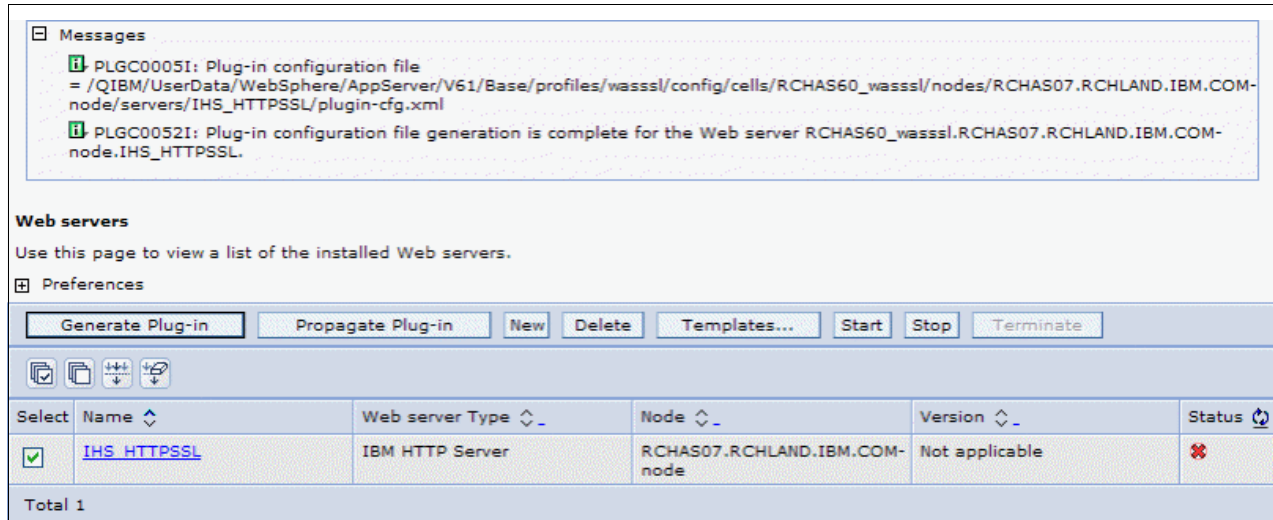

Figure 8-19 Generate plug-In

8. Click the **Log out** link in the top right corner of the window.
9. After you configure the virtual host, restart your WebSphere Application Server instance for the change to take effect.

### 8.3.7 Regenerating and propagating the plug-in configuration file

Now you need to capture new configuration parameters by regenerating and propagating the plug-in configuration file:

1. After you restart the WebSphere Application Server profile, logon to the WebSphere Administrative Console on the application server system. In the WebSphere Administrative Console, perform the following steps:
2. Expand **Servers** → **Web servers**.
3. Select your Web server instance (IHS\_HTTPSSL in our example).

**Important:** If you did not regenerate the plug-in configuration file in the last step, do it now. Click **Generate Plug-In** to regenerate the plugin-cfg.xml file.

4. Select the check box next to your Web server profile (IHS\_HTTPSSL in our case), and click **Propagate Plug-In** to propagate (copy) the updated plugin-cfg.xml file to the Web server system. Figure 8-20 on page 258 shows an example of the output.

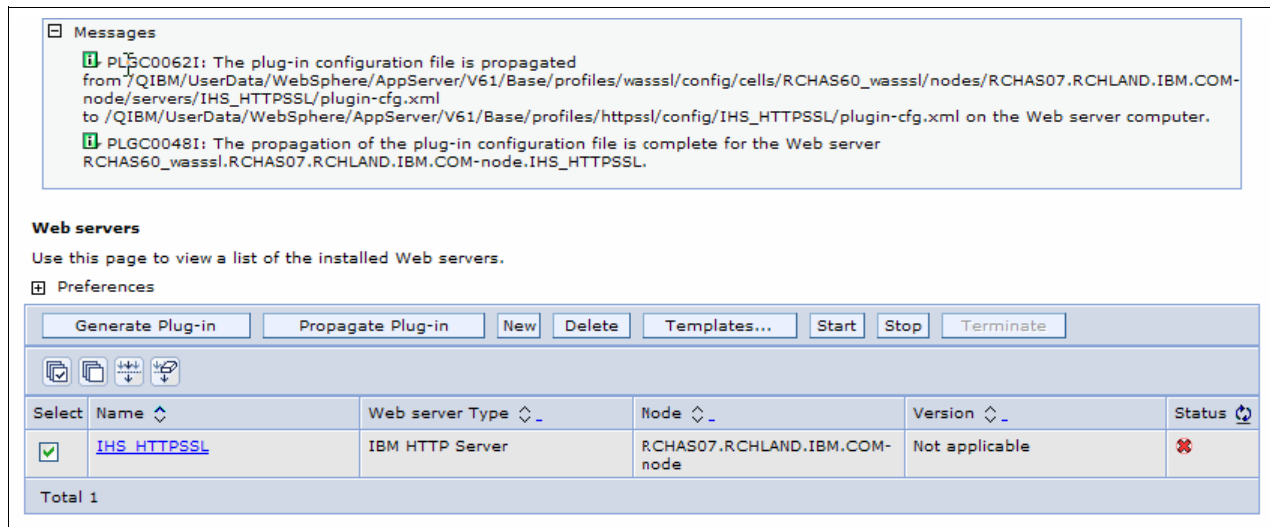

Figure 8-20 Propagate Plug-In

5. Select the check box next to **IHS\_HTTPSSL**, and click **Start**.

### 8.3.8 Verifying the configuration

You can use the Snoop servlet, which shipped with WebSphere Application Server, to verify that the Web server and the application server can communicate properly at this stage. Point a Web browser to your HTTP server listening port (on RCHAS07 in our example):

`http://RCHAS07:52480/snoop`

The Snoop Servlet Request page is displayed. You can see from the output that we connect to the Web server (*Server name* parameter in the output), which then forwards the request to the application server (*Local host* parameter in the output).

### 8.3.9 Checking messages in http\_plugin.log

You can find the log file for the Web server plug-in on the Web server system (on RCHAS07 in our example) at:

`<https1_profile_root>/logs/IHS_HTTPSSL/http_plugin.log`

In our case the location is:

`/QIBM/UserData/WebSphere/AppServer/V61/Base/profiles/https1/logs/IHS_HTTPSSL/http_plugin.log.`

Check the `http_plugin.log` on the Web server system (RCHAS07) for any error messages, such as: "ERROR: lib\_security: logSSLerror: str\_security (gsk error 201): Object containing the password for the certificate store file not found" (Figure 8-21 on page 259).

```

011759/QTMHHTTP/HTTPSSL 00000000 00000037 - ERROR: lib_security: logSSLError: str_security (gsk error 201): Object containing the password for the certificate store file not found.
[Mon Aug 21 16:10:27 2006] 011759/QTMHHTTP/HTTPSSL 00000000 00000037 - ERROR: lib_security: initializeSecurity: Failed to initialize GSK environment
[Mon Aug 21 16:10:27 2006] 011759/QTMHHTTP/HTTPSSL 00000000 00000037 - ERROR: ws_transport: transportInitializeSecurity: Failed to initialize security
[Mon Aug 21 16:10:27 2006] 011759/QTMHHTTP/HTTPSSL 00000000 00000037 - ERROR: ws_server: serverAddTransport: Failed to initialize security
[Mon Aug 21 16:10:27 2006] 011759/QTMHHTTP/HTTPSSL 00000000 00000037 - ERROR: ws_server: serverAddTransport: HTTPS Transport is skipped
[Mon Aug 21 16:10:27 2006] 011759/QTMHHTTP/HTTPSSL 00000000 00000037 - ERROR: ws_server: serverAddTransport: Plugin will continue to startup, however, SSL transport RCHAS60.ITSO.IBM.COM:52402 did not initialize. Secure communication between app server and plugin will NOT occur. To run with SSL, additional products may need to be installed: 1) OS/400 Digital Certificate Manager (5722-SS1 or 5769-SS1, option 34) 2) Cryptographic Access Provider 5769-AC1 (40-bit), 5722-AC2 or 5769-AC2 (56-bit), 5722-AC3 or 5769-AC3 (128-bit)
[Mon Aug 21 16:10:27 2006] 011759/QTMHHTTP/HTTPSSL 00000000 00000037 - PLUGIN: Plugins loaded.

```

Figure 8-21 GSK error 201 in the http\_plugin.log

Also check this file for "ERROR: lib\_security: logSSLError: str\_security (gsk error 202): Key database file was not found" (Figure 8-22).

```

011651/QTMHHTTP/HTTPSSL 00000000 00000b39 - ERROR: lib_security: logSSLError: str_security (gsk error 202): Key database file was not found.
[Mon Aug 21 15:36:49 2006] 011651/QTMHHTTP/HTTPSSL 00000000 00000b39 - ERROR: lib_security: initializeSecurity: Failed to initialize GSK environment
[Mon Aug 21 15:36:49 2006] 011651/QTMHHTTP/HTTPSSL 00000000 00000b39 - ERROR: ws_transport: transportInitializeSecurity: Failed to initialize security
[Mon Aug 21 15:36:49 2006] 011651/QTMHHTTP/HTTPSSL 00000000 00000b39 - ERROR: ws_server: serverAddTransport: Failed to initialize security
[Mon Aug 21 15:36:49 2006] 011651/QTMHHTTP/HTTPSSL 00000000 00000b39 - ERROR: ws_server: serverAddTransport: HTTPS Transport is skipped
[Mon Aug 21 15:36:49 2006] 011651/QTMHHTTP/HTTPSSL 00000000 00000b39 - ERROR: ws_server: serverAddTransport: Plugin will continue to startup, however, SSL transport RCHAS60.ITSO.IBM.COM:52402 did not initialize. Secure communication between app server and plugin will NOT occur. To run with SSL, additional products may need to be installed: 1) OS/400 Digital Certificate Manager (5722-SS1 or 5769-SS1, option 34) 2) Cryptographic Access Provider 5769-AC1 (40-bit), 5722-AC2 or 5769-AC2 (56-bit), 5722-AC3 or 5769-AC3 (128-bit)
[Mon Aug 21 15:36:49 2006] 011651/QTMHHTTP/HTTPSSL 00000000 00000b39 - PLUGIN: Plugins loaded.

```

Figure 8-22 GSK error 202 in the http\_plugin.log

If you see either GSK error 201 or GSK error 202 in the http\_plugin.log at this stage, you need to perform additional configuration for your WebSphere Application Server plug-in, which we describe next. If these errors do not appear in your http\_plugin.log, you can skip the next section.

### 8.3.10 Additional configuration required for WebSphere Application Server plug-in

If GSK error 201 appears in the http\_plugin.log, you need to:

- ▶ Manually stash the password for the plugin-key.kdb file. Review the following topic in the Information Center:

[http://publib.boulder.ibm.com/InfoCenter/wasinfo/v6r1/index.jsp?topic=/com.ibm.websphere.base.iseries.doc/info/iseres/ae/tsec\\_sslreckeystorepwrec.html](http://publib.boulder.ibm.com/InfoCenter/wasinfo/v6r1/index.jsp?topic=/com.ibm.websphere.base.iseries.doc/info/iseres/ae/tsec_sslreckeystorepwrec.html)

When you review the Information Center topic, note that:

- The default path name of the plugin-key.kdb file is:

```
<profile_root>/config/<webServerDefinitionName>/plugin-key.kdb
```

In our example, the default path name of the plugin-key.kdb file is:

```
/QIBM/UserData/WebSphere/AppServer/V61/Base/profiles/httpssl/config/IHS_HTTPSSL/plugin-key.kdb
```

- The default keystore password is WebAS.

If GSK error 202 appears in the http\_plugin.log, you need to:

- ▶ Configure the unrestricted Java Cryptography Extension (JCE) jurisdiction policy files for Software Developer Kit (SDK) Version 1.5.
- ▶ Copy the plugin-key.kdb file to the plug-in installation directory.
- ▶ Complete the steps in the Technote, which is located at:

[http://www-1.ibm.com/support/docview.wss?rs=180&context=SSEQTP&q1=Additional+configuration&uid=swg21237873&loc=en\\_US&cs=utf-8&lang=en](http://www-1.ibm.com/support/docview.wss?rs=180&context=SSEQTP&q1=Additional+configuration&uid=swg21237873&loc=en_US&cs=utf-8&lang=en)

**Attention:** Do not forget to restart the WebSphere Application Server and the HTTP server after you make changes.

**Note:** Step 2d of the above Technote mentions the following:

“Go down to the *Web server copy of Web server plug-in files* section, and click **Copy to Web server key store directory**.”

We found in our case that the **Copy to Web server key store directory button** was in fact under the *Repository copy of Web server plug-in files* section.

### 8.3.11 Enabling the secure transport between the Web server and the application server systems

Use the following steps to enable the secure transport between the Web server and the application server systems:

1. After you restart WebSphere Application Server, logon to the WebSphere Administrative Console on the application server system.





2. In the administrative console, expand **Servers** → **Application servers** and click **wassl**.
3. Expand **Web Container Settings**, and click **Web Container Transport Chains**.
4. Click **WCInboundDefault**, as shown in Figure 8-23.

[Application servers](#) > [wassl](#) > **Web container transport chains**

Use this page to view and manage a transport chain. Transport chains represent network protocol stacks operating within a client or server.

⊕ Preferences

New Delete

Select	Name ▾	Enabled	Host ▾	Port ▾	SSL Enabled
<input type="checkbox"/>	<a href="#">WCInboundAdmin</a>	Enabled	*	52401	Disabled
<input type="checkbox"/>	<a href="#">WCInboundAdminSecure</a>	Enabled	*	52403	Enabled
<input type="checkbox"/>	<a href="#">WCInboundDefault</a>	Enabled	*	52400	Disabled
<input type="checkbox"/>	<a href="#">WCInboundDefaultSecure</a>	Enabled	*	52402	Enabled

Total 4

Figure 8-23 Web container transport chains

5. Deselect **Enabled**, as shown in Figure 8-24 on page 262, which results in the WCInboundDefaultSecure transport being used after WebSphere Application Server is restarted.

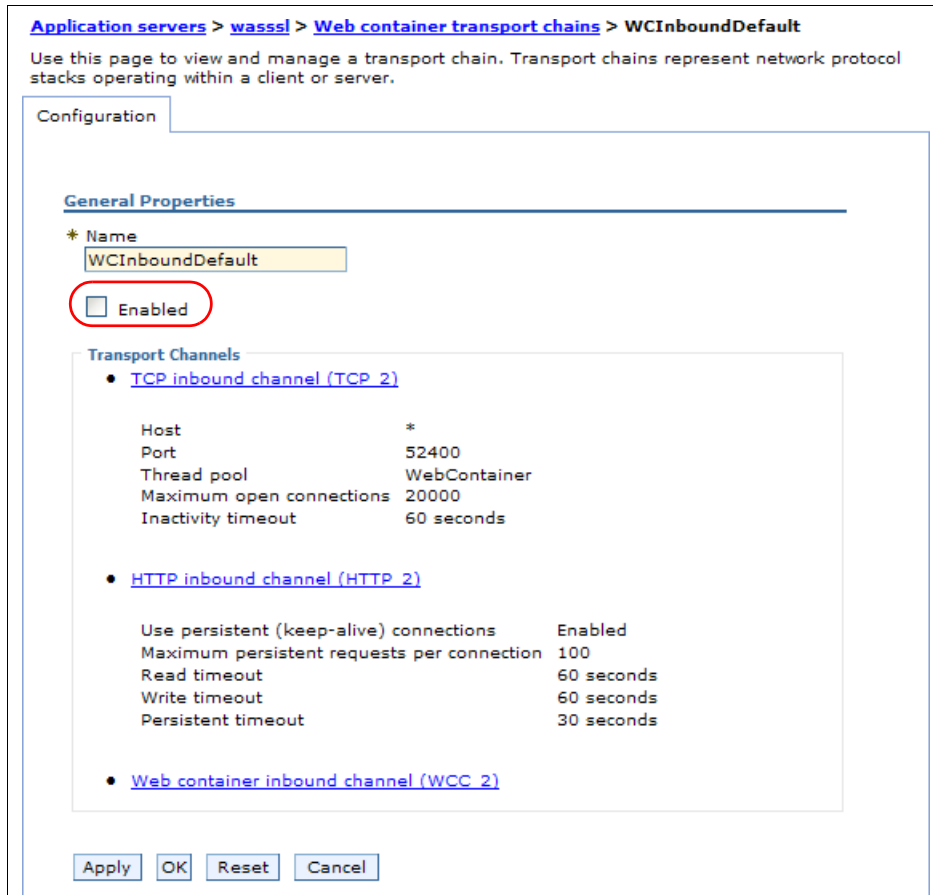

Figure 8-24 WCInboundDefault transport chain configuration

6. Click **OK**, and Save your changes.
7. Restart the application server (wasss!).
8. After you restart WebSphere Application Server, logon to the WebSphere Administrative Console on the application server system, and expand **Servers** → **Web servers**. Select the check box next to your Web server (IHS\_HTTPSSL).
9. Click **Generate Plug-In** to regenerate the plugin-cfg.xml file.
10. Select the **IHS\_HTTPSSL** check box, and click **Propagate Plug-In** to propagate the plugin-cfg.xml file to the Web server system.
11. Restart the Web server (IHS\_HTTPSSL).

### 8.3.12 Verifying that the secure transport is working

The final step in SSL configuration between the HTTP server instance and the application server is to test it:

1. Point a Web browser at the Snoop servlet, and specify the Web server host name:

`http://<HTTP_system_hostname>:52480/snoop`

You should see the Snoop data returned. Notice how the Local port parameter, in the Snoop output that the request was forwarded to on the application server, changed compared to the test that you did in 8.3.8, "Verifying the configuration" on page 258.

We also see (example in Figure 8-25) that the communication is now SSL-enabled.

**Note:** You will see no padlock symbol in your Web browser status bar. The secure communication is only between the Web server and WebSphere Application Server, not between the Web browser and the Web server.

### HTTPS Information:

Cipher Suite	SSL_RSA_WITH_RC4_128_MD5
--------------	--------------------------

Figure 8-25 Snoop Servlet with 128-bit encryption

## 8.4 Configuring SSL between the Web Browser and the HTTP Server

So far, we described how to secure communication between the Web server and the application server systems. In practice, these machines may be relatively isolated from outside threats. In some applications (for example, internet banking or e-commerce), it is vital to also secure communication between the Web browser and the Web server to prevent eavesdropping.

In this section, we discuss how to configure SSL between Web browsers and your Web server, using the following steps:

1. Create your own SSL certificate.
2. Install the certificate with the IBM HTTP Server (powered by Apache).
3. Change your WebSphere Application Server V6.1 for i5/OS configuration to accept SSL requests.

Figure 8-26 shows the part of the topology that we configure in this section.

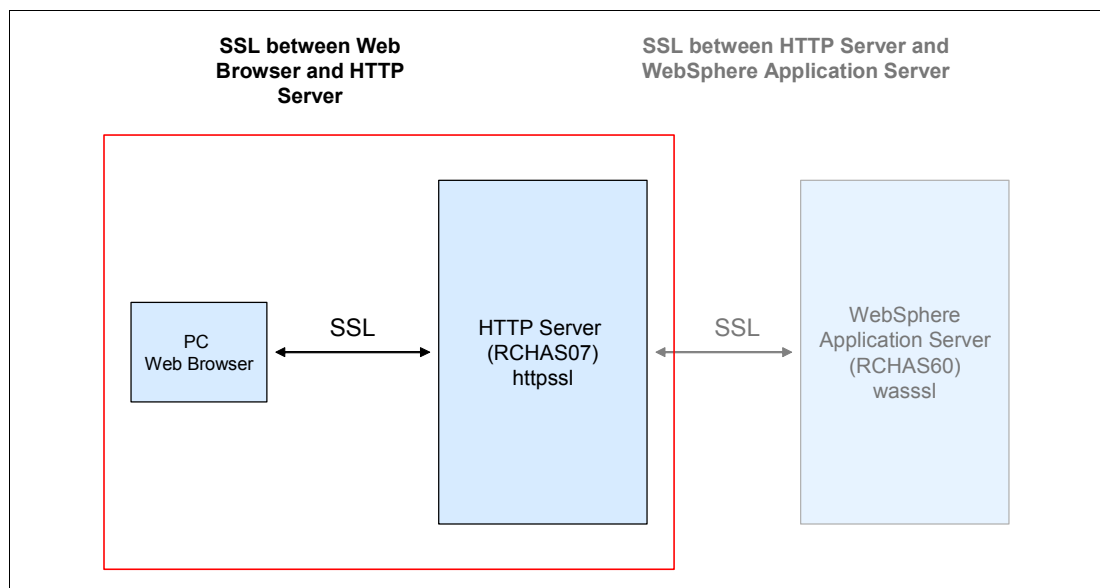

Figure 8-26 Configuring SSL between the Web browser and the Web server

We use the same environment that we used in section 8.2, “Enabling SSL” on page 246, namely:

- ▶ Web server (RCHAS07)
- ▶ HTTP server name: https1
- ▶ HTTP port: 52480
- ▶ WebSphere Application Server V6.1 with the default installation path:  
/QIBM/ProdData/WebSphere/AppServer/V61/Base/bin

### 8.4.1 Creating your own SSL certificate

Creating your own SSL certificate is a two-step process:

- ▶ First, you create a local Certificate Authority (CA) to allow you to issue SSL certificates.
- ▶ Using the CA, you create a Server Certificate to be used by the Web server during the SSL ‘handshake’ with a Web browser.

In the following section, we cover these tasks.

**Note:** In our example, we use a system with no prior SSL configuration. When you work on your own system, you may have parts of the SSL infrastructure already created. In this case, skip the section in the book that provides instructions about that part which is already configured on your system.

#### Creating a local Certificate Authority

A Certificate Authority (CA) is a central administrative entity that can issue digital certificates to users and servers. The Certificate Authority signs certificates with its private key to validate their authenticity. A CA can be a publicly available entity, such as VeriSign, or it can be a privately created entity, such as a private intranet or local CA. Digital Certificate Manager (DCM) allows you to use both types of CAs to request and install certificates. For our purposes, we created our own local Certificate Authority. Use the following steps to set up a local Certificate Authority using the wizard that is built into DCM:

1. Logon to the i5/OS Tasks page by entering the URL that is pointing to the Web server system:

```
http://<HTTP_system_hostname>:2001
```

2. Sign on with your user ID and password:

**Note:** The user profile needs to have \*ALLOBJ and \*SECADM special authorities.

3. Click **Digital Certificate Manager**. Figure 8-27 on page 265 shows the start page for Digital Certificate Manager (DCM).
4. Click **Create a Certificate Authority (CA)**.



Figure 8-27 Digital Certificate Manager start page

**Note:** If the Create a Certificate Authority (CA) option is not visible in the DCM menu, it means that a CA was created on the server. DCM subsequently removes this option from the menu. In this case, you can skip to “Creating a Server Certificate” on page 268.

5. Complete the Create a Certificate Authority (CA) form using the appropriate values for your organization, as shown in Figure 8-28 on page 266, and click **Continue**.

Digital Certificate Manager processes the form and creates the following directories and files:

- /QIBM/UserData/ICSS/Cert/CertAuth directory containing the following objects:
  - CA.TXT: Contains the CA certificate in encoded form
  - DEFAULT.KDB: Contains the private key and the CA certificate
  - DEFAULT.POL: Is the CA policy file
  - DEFAULT.RDB: Is the CA's request database
- /QIBM/UserData/ICSS/Cert/Download/CertAuth directory containing the CA.CACRT binary form of CA certificate.

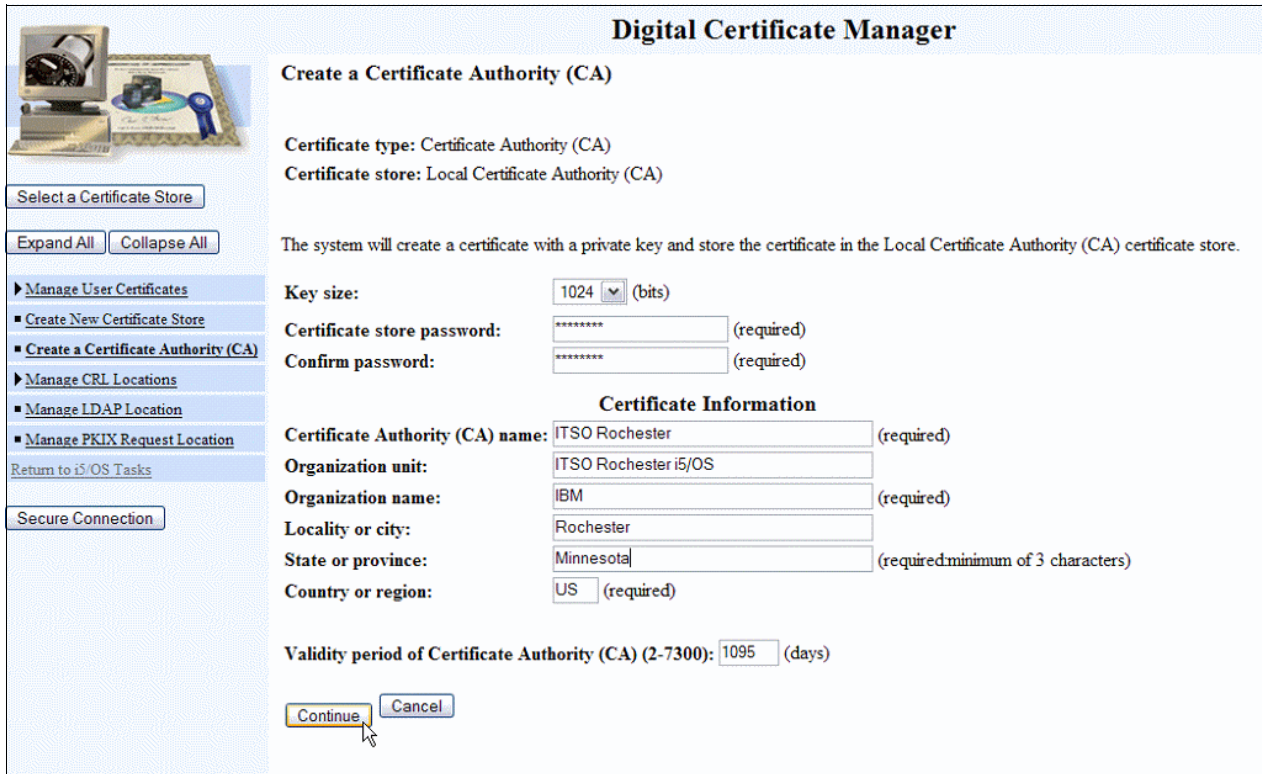

Figure 8-28 Create a Certificate Authority

Next DCM prompts you need to install the CA certificate to your Web browser as shown in Figure 8-29.



Figure 8-29 Install Local CA Certificate

6. Click the **Install certificate** link. Your browser prompts you with security warnings. Ignore these warnings, and click **Open** to begin the installation.
7. Follow the instructions that your browser issues to install the certificate on your PC.
8. Click **Continue**. The Certificate Authority (CA) Policy Data page (Figure 8-30) appears.

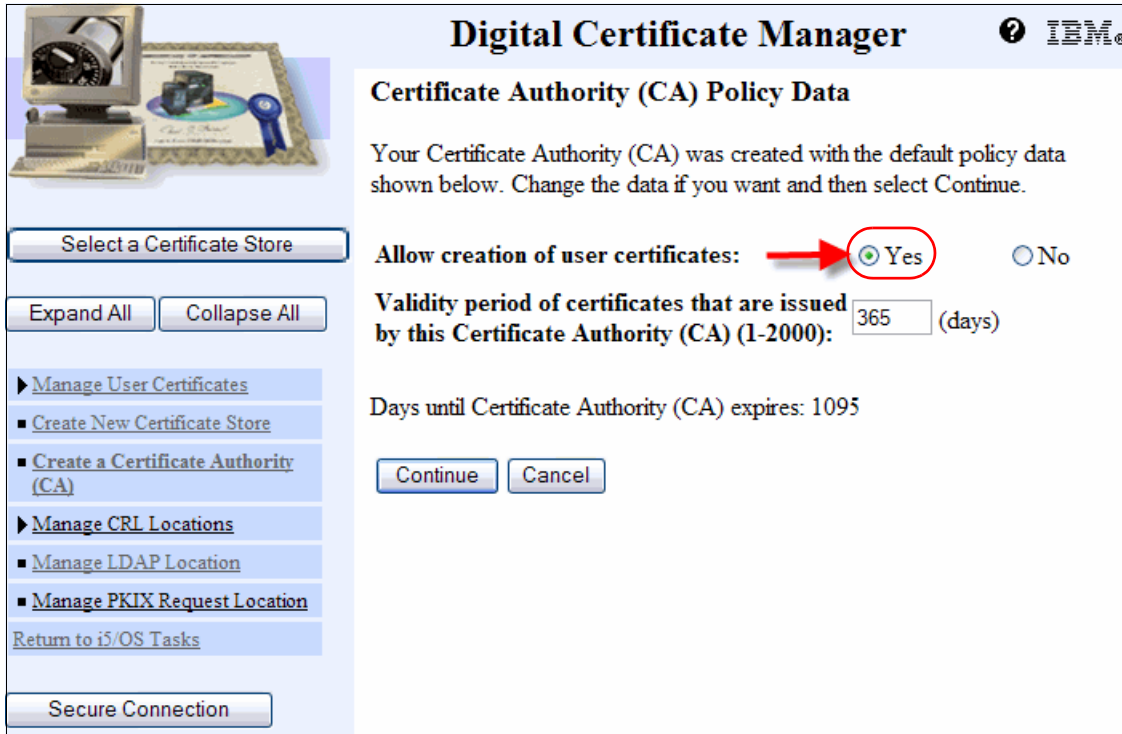

Figure 8-30 Certificate Authority (CA) Policy Data

9. Select **Yes** to Allow creation of user certificates (Figure 8-30), and click **Continue**.
10. The next panel shows that the CA was created. You can select the applications that can include this CA in their trust list. Select the check box next to **QIBM\_HTTP\_SERVER\_HTTPSSL**, and click **Continue** (see Figure 8-31 on page 268).

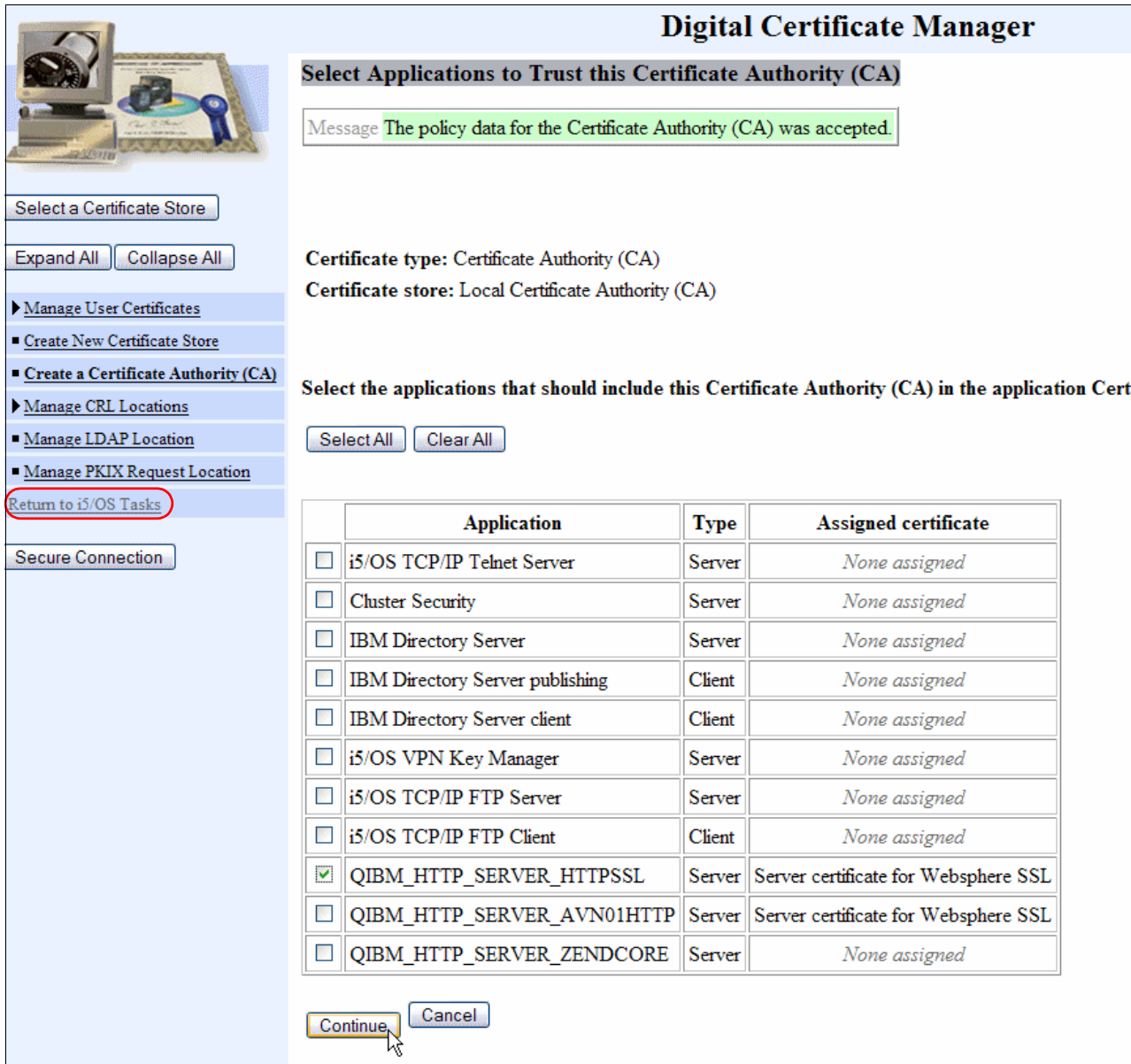

Figure 8-31 Policy Data Accepted

## Creating a Server Certificate

11. Click **Return to i5/OS Tasks** in the Navigation menu (Figure 8-31), and click the **Digital Certificate Manager** link.
12. Click the **Select a Certificate Store** button in the Navigation menu.
13. On Figure 8-32 on page 269, select **\*SYSTEM**, and click **Continue**.

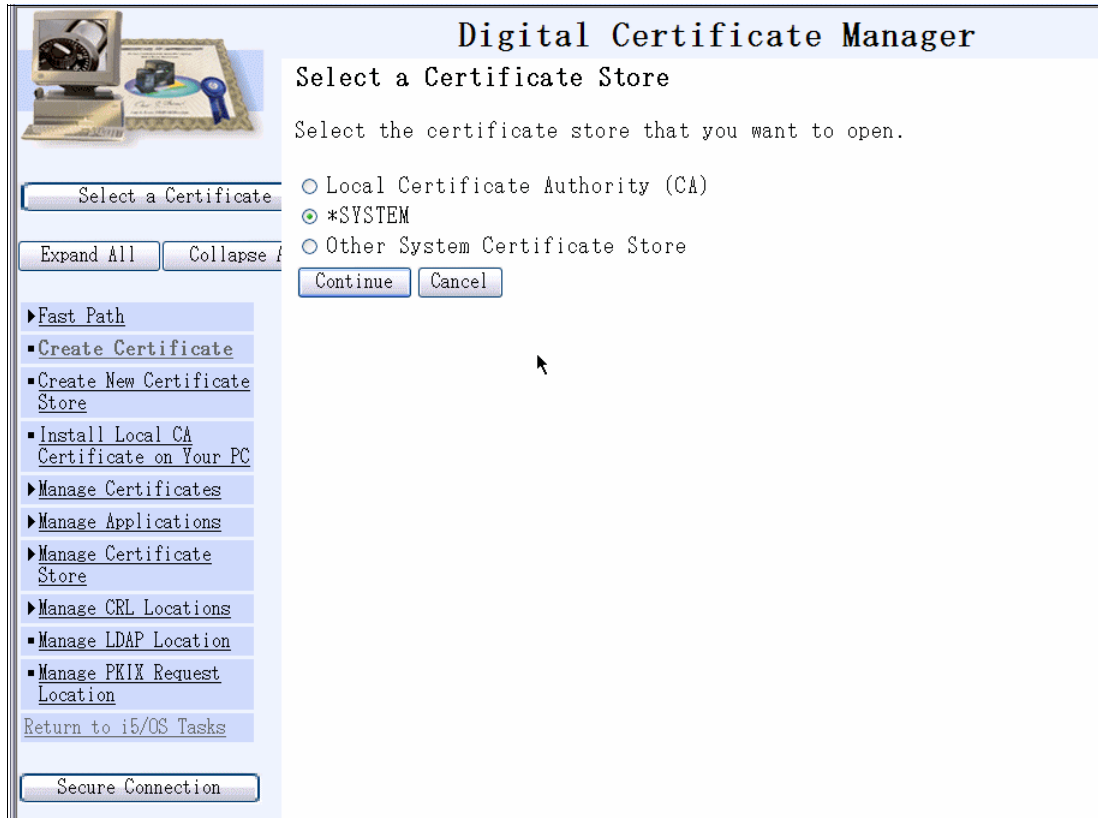

Figure 8-32 Selecting a certificate store

14. On the next window (Figure 8-33), type a password for the selected certificate store, and click **Continue**.



Figure 8-33 Specifying a password

15. In the next panel, click the **Create Certificate** link in the Navigation pane on the left.
16. In the Create Certificate window, select **Server or client certificate**, and click **Continue**.
17. Leave the **Local Certificate Authority** option selected, and click **Continue**. The DCM guides you through a server certificate creation. The secure HTTP server uses this certificate during the SSL handshake with Web browser clients. You are prompted to complete information for this certificate that is placed in the \*SYSTEM store.

18. Complete the Create a Server or Client Certificate form using appropriate values for your organization, as shown in Figure 8-34.

**Note:** If you typed the Certificate Store password before, you will not see the password boxes.

**Digital Certificate Manager** IBM

### Create a Server or Client Certificate

**Certificate type:** Server or client  
**Certificate store:** \*SYSTEM

The system will create a certificate with a private key and store the certificate in the default server certificate store (\*SYSTEM).

**Key size:**  (bits)

**Certificate label:**  (required)

**Certificate store password:**  (required)

**Confirm password:**  (required)

#### Certificate Information

**Common name:**  (required)

**Organization unit:**

**Organization name:**  (required)

**Locality or city:**

**State or province:**  (required minimum of 3 characters)

**Country or region:**  (required)

#### Subject Alternative Name

**Note:** Certificate extensions are not necessary for Secure Sockets Layer (SSL), but are recommended for Virtual Private Network (VPN).

**IP version 4 address:**  .  .  .

**Fully qualified domain name:**  (host\_name.domain\_name)

**E-mail address:**  (user\_name@domain\_name)

Figure 8-34 Create a Server or Client Certificate

19. Click **Continue**. DCM creates the system certificate in the \*SYSTEM certificate store. The \*SYSTEM certificate store consists of the following files in /QIBM/UserData/ICSS/Cert/Server:

- DEFAULT.KDB: Contains server and client certificates with their private keys
- DEFAULT.RDB: Is the certificate request database

At the top of the window, a confirmation message appears stating that the server certificate was created.

20. DCM displays the next window, which prompts you to select applications that will trust certificates issued by your newly-created CA.

For now, select **no applications**, and click **Continue** (we perform this step later in this section). DCM then prompts you to create an Object Signing Certificate Store, as shown in Figure 8-35.

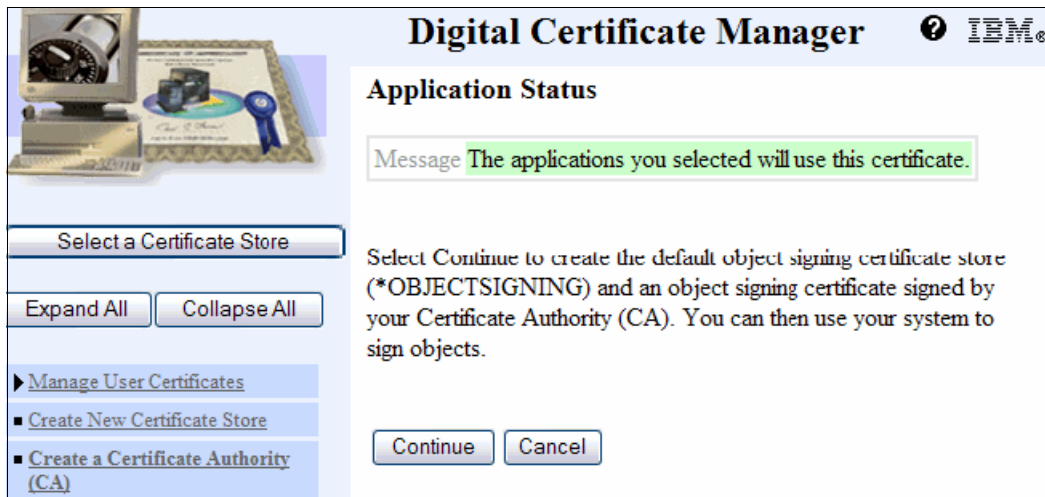

Figure 8-35 Application Status

## Creating an Object Signing store

Use the following steps to create an Object Signing store:

1. To create an Object Signing Certificate, on the Application Status window (Figure 8-35), click **Continue**.

**Note:** An Object Signing Certificate is a certificate that you use to digitally sign an object to ensure the integrity of both the object itself and the origination or ownership of the object. Objects include i5/OS programs, save files, and stream files. When you use an object signing certificate's private key to sign an object, the receiver of the object must have access to a copy of the corresponding signature verification certificate to properly authenticate the object signature. You manage these certificates by using an Object Signing Certificate store. Although the Object Signing Certificate store is not required for our purposes, it makes sense to configure it at this time while the DCM wizard is running.

If the \*OBJECTSIGNING certificate store was created before, you just need to switch to that store.

**Digital Certificate Manager** IBM

### Create an Object Signing Certificate

Certificate type: Object signing  
 Certificate store: \*OBJECTSIGNING

The system will create a certificate with a private key and store the certificate in the default object signing certificate store (\*OBJECTSIGNING).

Key size: 1024 (bits)

Certificate label: Standard system Object Signing Certificate (required)

Certificate store password: ..... (required)

Confirm password: ..... (required)

#### Certificate Information

Common name: wasssl (required)

Organization unit: [ ]

Organization name: ITSO Rochester i5/OS (required)

Locality or city: Rochester

State or province: Minnesota (required; minimum of 3 characters)

Country or region: US (required)

Continue Cancel

Select a Certificate Store

Expand All Collapse All

- Manage User Certificates
- Create New Certificate Store
- Create a Certificate Authority (CA)
- Manage CRL Locations
- Manage LDAP Location
- Manage PKIX Request Location

Return to i5/OS Tasks

Secure Connection

Figure 8-36 Create an Object Signing Certificate

2. Enter the certificate's subject information (Figure 8-36) as you did previously for the server certificate, and click **Continue**. The window contains a confirmation message about the creation of the Object Signing Certificate. If you used object signing previously on this system, a list of available object signing applications appears. You can then select the applications for which you want to use the new certificate. In a new system environment, there are no applications shown.
3. Click **Continue**.
4. You now must select all the applications that will trust the newly created Certificate Authority. The list contains all registered client applications and the server applications that support client authentication. At this point, your HTTP server is not listed, so click **Continue**.

5. A final confirmation message (Figure 8-37) appears. Click **OK** to complete the setup.



Figure 8-37 Application status

## Setting a default certificate label

The first time the local CA and \*SYSTEM certificate store are created, there is no default certificate assigned to the certificate store. As long as all SSL applications specify explicitly a certificate when establishing an SSL session, the default certificate setting is not important. But there are also applications, mostly user written ones, that may not specify a certificate; thus, the default certificate is chosen. For this reason, we recommend that you set a default certificate label for the \*SYSTEM certificate store.

To set a default certificate label for the \*SYSTEM certificate store:

1. On the Digital Certificate Manager navigation pane, click **Select a Certificate Store**.
2. Select the **\*SYSTEM** certificate store, and click **Continue**.
3. Enter the certificate store password, and click **Continue**.
4. Click **Fast Path**.
5. From the Fast Path options, click **Work with server and client certificates**, as shown in Figure 8-38 on page 274.

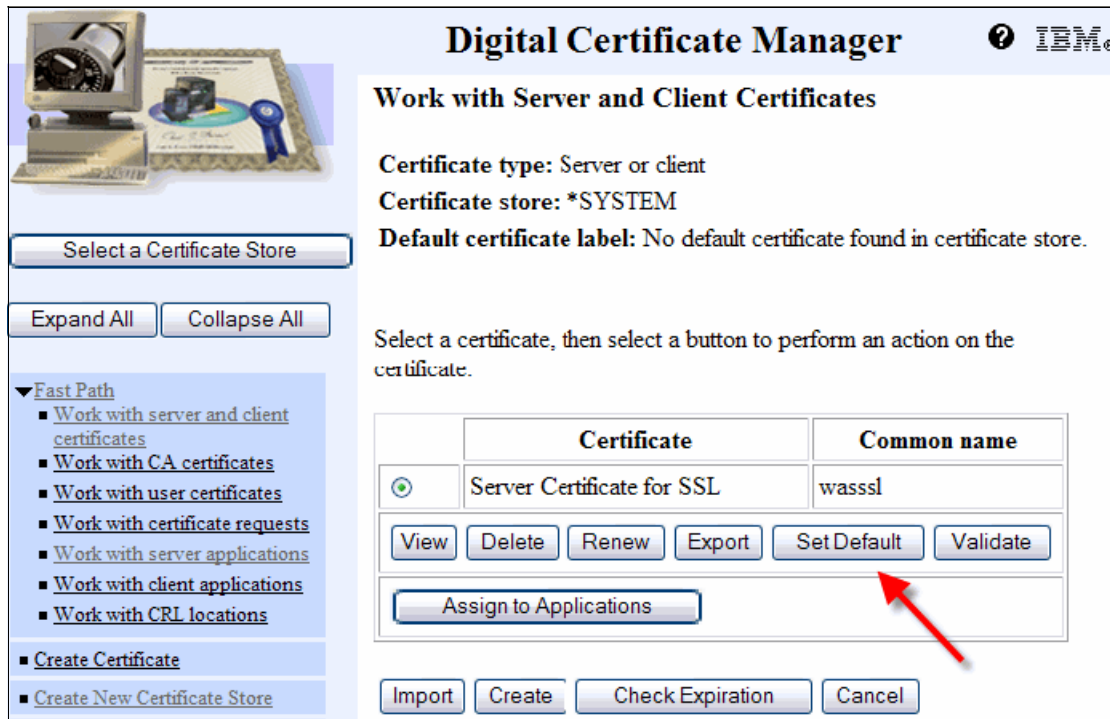

Figure 8-38 Work with Server and Client Certificates

6. To assign a default certificate label to the \*SYSTEM certificate store, choose the server certificate that you want to use as the default certificate (Figure 8-38), and click **Set Default**.
7. Click **Cancel** to complete the setup.

### Creating a server certificate for the Web server using the local CA

A server certificate is a digital document that validates the identity of the system or server that owns the certificate. Server certificates are issued by a Certificate Authority and contain identifying information about the server, such as the server's distinguished name. The certificate also contains the server certificate's public key. A server must have a digital certificate to use Secure Sockets Layer (SSL) for secure communications. Most i5/OS applications, such as the HTTP server, Telnet server, and so on, support SSL and can examine a server's certificate to verify the identity of the server when the client program requests a secure connection.

We now create a server certificate using our local Certificate Authority, to use with our HTTP server instance:

1. On the Digital Certificate Manager start page, click the **Select a Certificate Store** button, as shown in Figure 8-27 on page 265.



Figure 8-39 Select a Certificate Store

2. Select the **\*SYSTEM** certificate store (Figure 8-39), and click **Continue**. The System Certificate Store is the standard store for managing server and client certificates that are used for secure applications.
3. Enter the certificate store password (Figure 8-40), and click **Continue**. The Navigation pane refreshes and all of the general options are available. The System Certificate Store appears. There are two methods for navigating through the DCM interface. You can use the individual links and submenus that are located on the Navigation pane, or you can use the Fast Path option.

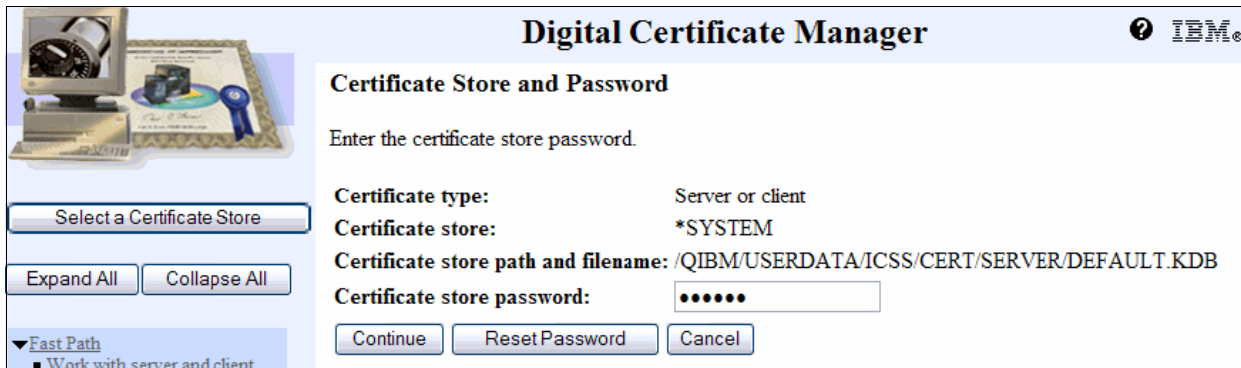

Figure 8-40 Certificate Store and Password

4. On the Navigation pane, click **Fast Path**.

- Under the Fast Path Navigation bar menu, click **Work with server and client certificates**, as shown in Figure 8-41.

Using the Fast Path method to perform DCM management tasks allows you to perform all of the tasks that are related to a category in one place, for example, the Work with Server and Client Certificates window shows all of the options that you need to perform certificate management tasks. The certificates for client and server applications are the same.

- Click **Create** to create a new certificate, as shown in Figure 8-41.



Figure 8-41 Work with certificates

The number of certificate authorities displayed depends on the selected configuration method (Figure 8-42 on page 277):

- Local Certificate Authority (CA): This option is only available when a local certificate authority was created on the system. When you create the certificate request, the signing request is automatically signed by the local CA and the signed certificate is imported into the System Certificate Store. The private key, which is created when you request a certificate, is stored in the System Certificate Store and does not leave the store.
- VeriSign or other Internet Certificate Authority (CA): Use this option to create a certificate signing request (CSR). The private key is generated and then stored in the System Certificate Store. The CSR is sent to the Internet CA, which signs the certificate and then sends the signed certificate back. The signed certificate must then be imported into the System Certificate Store. This option is always available.

7. Because we are using the local CA that we previously created, select **Local Certificate Authority (CA)**, and click **Continue** as shown in Figure 8-42.



Figure 8-42 Select a Certificate Authority

8. Complete the form (Figure 8-43 on page 278) with information that is relevant to your company, and click **Continue**.

**Digital Certificate Manager**

### Create Certificate

Certificate type: Server or client  
 Certificate store: \*SYSTEM

Select a Certificate Store

Expand All Collapse All

**Fast Path**

- Work with server and client certificates
- Work with CA certificates
- Work with user certificates
- Work with certificate requests
- Work with server applications
- Work with client applications
- Work with CRL locations
- Create Certificate**
- Create New Certificate Store
- Install Local CA Certificate on Your PC
- Manage Certificates
- Manage Applications
- Manage Certificate Store
- Manage CRL Locations
- Manage LDAP Location
- Manage PKIX Request Location
- Return to i5/OS Tasks

Secure Connection

Use this form to create a certificate in the certificate store listed above.

Key size: 1024 (bits)

Certificate label: Server certificate for Websphere SSL (required)

#### Certificate Information

Common name: Websphere SSL (required)

Organization unit:

Organization name: ITSO Rochester i5/OS (required)

Locality or city: Rochester

State or province: Minnesota (required minimum of 3 characters)

Country or region: US (required)

#### Subject Alternative Name

Note: Certificate extensions are not necessary for Secure Sockets Layer (SSL), but are recommended for Virtual Private Network (VPN).

IP version 4 address: . . .

Fully qualified domain name: (host\_name.domain\_name)

E-mail address: (user\_name@domain\_name)

Continue Cancel

Figure 8-43 Create Certificate

- Do not select any applications at this time (Figure 8-44 on page 279); instead, click **Cancel**.



Figure 8-44 Select Applications for certificate

At this stage, we have the basic infrastructure in place for creating and signing the X.509 certificates that are required for SSL, using a common procedure that applies regardless of the application that will use SSL. We now need to perform additional configuration for our particular scenario.

## 8.4.2 Enabling SSL in your HTTP server instance

We now enable SSL for your HTTP server instance, which requires a number of steps because we need to allocate a new virtual host to handle the SSL connections, create a new server certificate application, and assign a certificate to that application.

Use the following steps to enable SSL in the Web server instance:

1. Launch your Web browser, and point it to the system where your HTTP Server instance resides:  
`http://<HTTP_system_hostname>:2001`
2. Sign on using your i5/OS User ID and password, and click **IBM Web Administration for i5/OS**.
3. Click the **Manage** tab, and select your HTTP server instance (https1 in our case).
4. On the task bar, click **General Server Configuration**. The General Server Configuration window appears, as shown in Figure 8-45 on page 280.

HTTPSSL > General Server Configuration

## General Server Configuration ?

General Settings | Welcome Pages | Configuration Includes | **Advanced**

Autostart: Global ?

Associated WAS Instance: httpssl, V6.1 Base

Product install path: /QIBM/ProdData/WebSphere/AppServer/V61/Base

Start all WebSphere application server(s) for the associated WAS instance when this HTTP server is started: No ?

Server root directory: /www/httpssl

Configuration file: conf/httpd.conf

Document root: /www/httpssl/htdocs 

Server name:

Fully qualified server host name: 

Port: 

Server IP addresses and ports to listen on: ?

	IP address	Port	FRCA
<i>Example</i>	All IP addresses	80	Disabled
<input type="radio"/>	*	52480	Disabled

Figure 8-45 General server configuration

5. Click the **Add** button to add a new port on which to listen for secure connections.
6. Leave the asterisk (\*) in the IP address column, and add the SSL port (normally 443 but we used 52480 in our example) in the Port column, and click **Apply**.
7. In the task bar, click **Virtual Hosts**, and then click the **IP Based** tab (Figure 8-47 on page 281). Add a new virtual host for your SSL port (443):
  - a. Click the **Add** button.
  - b. Type '\*' in the IP address or host name field.
  - c. Type the SSL port (443 in our case) in the Port field (Figure 8-46 on page 281), and click **Continue**.

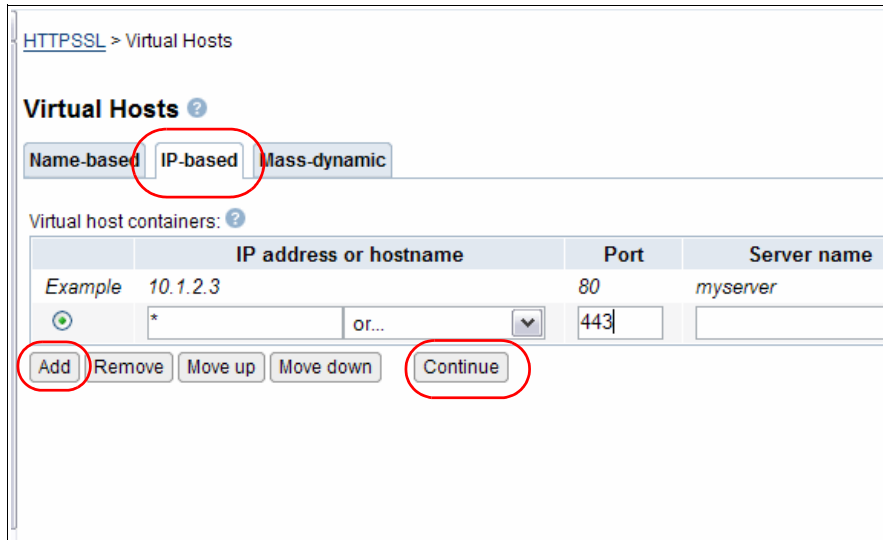

Figure 8-46 Adding a virtual host

8. Click **Apply**. In the Server area drop-down menu, a new entry for Virtual Host \*:443 appears, as shown in Figure 8-47.
9. You are now required to enable SSL for the new virtual host that we created. From the top menu, select the **Virtual Host area** (Figure 8-47).

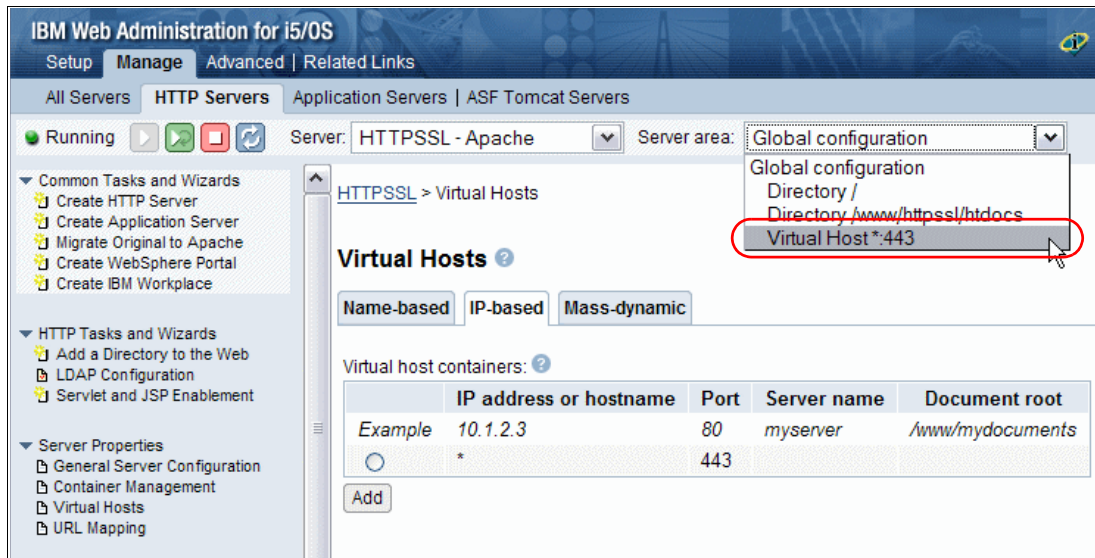

Figure 8-47 Virtual Hosts

10. Enable SSL in the HTTP server instance configuration, as shown in Figure 8-48 on page 282:
  - a. In the Navigation menu, select **Security**. The security settings appear.
  - b. In the SSL pull-down menu, select **Enabled**.
  - c. In the Server certificate application name field, select the application name that matches your HTTP server from the drop-down menu (format is QIBM\_HTTP\_SERVER\_<INSTANCE\_NAME>), in our case **QIBM\_HTTP\_SERVER\_HTTPSSL**.

- d. Select the **Do not request client certificate for connection** option.
- e. Click **Apply**.

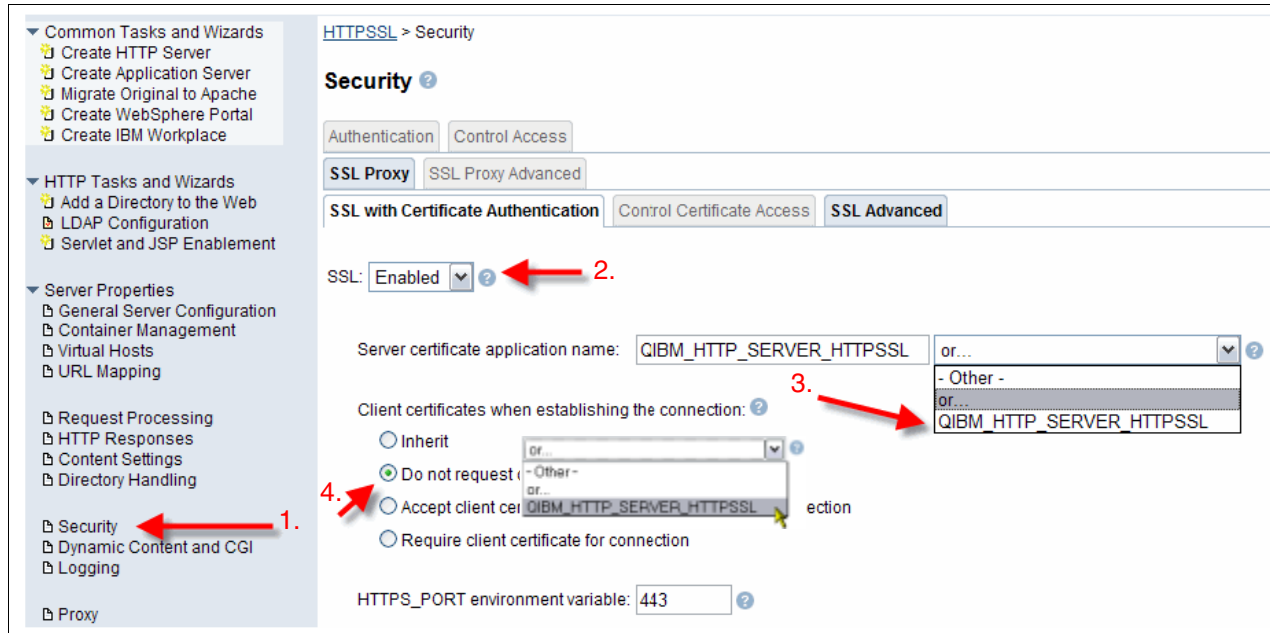

Figure 8-48 Security settings

**Important:** You receive a message saying that the server needs to be restarted. Do *not* restart the server yet. If you do restart the server now, the HTTP server will fail to start. We have a few more steps to complete first.

### 8.4.3 Adding a virtual host for SSL to WebSphere Application Server

We need to update the virtual host to accept incoming requests on our SSL port, which is essentially replicating the changes we did to the HTTP server instance:

1. Connect to the WebSphere Administrative Console on the WebSphere Application Server system (RCHAS60 in our example), by directing a Web browser to:  

```
http://rchas60:52401/ibm/console/
```
2. Login with your user ID and password.
3. Expand **Environment** → **Virtual Host** → **default\_host**, and click **Host Aliases**.
4. If your HTTP server SSL port is not in the list, click the **New** button.
5. Add the SSL port, as shown in Figure 8-49 on page 283, and click **Apply**.



Figure 8-49 Add SSL port

6. Restart the WebSphere Application Server instance to ensure that the changes take effect.
7. Restart your HTTP server instance.

#### 8.4.4 Assigning a certificate to the HTTP server instance

Finally we need to assign the certificate, which we created in “Creating a server certificate for the Web server using the local CA” on page 274, to the HTTP server:

1. Open a Web browser, and go to IBM Web Administration for i5/OS on the Web server machine (RCHAS07 in our example) by entering the following URL:  
`http://<HTTP_system_hostname>:2001`
2. Sign on with your user ID and password.

**Note:** The user profile needs \*ALLOBJ and \*SECADM special authorities.

3. Click **Digital Certificate Manager**.
4. On the Navigation pane, click the **Select a Certificate Store** button.
5. Select the **\*SYSTEM** certificate store, and click **Continue**.
6. Enter your password, and click **Continue**.
7. Click **Fast Path**.
8. Select **Work with server applications**, and click **Continue**. A list of available applications are listed. Figure 8-50 on page 284 shows an example list of applications.

## Digital Certificate Manager

### Work with Server Applications

**Application type:** Server

You can add an application or select an application to work with from the list.

**Applications registered to use certificates:**

	Application	Certificate Assigned
<input checked="" type="radio"/>	Central Server	None assigned
<input type="radio"/>	Database Server	None assigned
<input type="radio"/>	Data Queue Server	None assigned
<input type="radio"/>	Network Print Server	None assigned
<input type="radio"/>	Remote Command Server	None assigned
<input type="radio"/>	Signon Server	None assigned
<input type="radio"/>	i5/OS TCP/IP Telnet Server	None assigned
<input type="radio"/>	i5/OS DDM/DRDA Server - TCP/IP	None assigned
<input type="radio"/>	Cluster Security	None assigned
<input type="radio"/>	Host Servers	None assigned
<input type="radio"/>	File Server	None assigned
<input type="radio"/>	Management Central Server	None assigned
<input type="radio"/>	IBM Directory Server	None assigned
<input type="radio"/>	i5/OS VPN Key Manager	None assigned
<input type="radio"/>	i5/OS TCP/IP FTP Server	None assigned
<input type="radio"/>	Webserver Search Engine	None assigned
<input type="radio"/>	HTTP Server Monitor	None assigned
<input type="radio"/>	QIBM_HTTP_SERVER_HTTPSSL	None assigned

Figure 8-50 Work with Server Applications

9. Scroll down to locate your Web server instance name in the list of applications that are registered to use certificates. In our case, we named it QIBM\_HTTP\_SERVER\_HTTPSSL.

10. Select the application, and click the **Work with Application** button. Figure 8-51 shows the details for the application.

### Work with Server Applications

**Application Information**

**Application type:** Server  
**Application ID:** QIBM\_HTTP\_SERVER\_HTTPSSL  
**Application description:** QIBM\_HTTP\_SERVER\_HTTPSSL

---

Certificate Revocation List (CRL) checking:  Yes  No

---

**Certificate Assigned:** *(None assigned)*

---

**Certificate Authority (CA) certificates in the application trust list:**

*(No Certificate Authorities (CAs) are trusted by this application.)*

---

Figure 8-51 Update Certificate Assignment

11. Click the **Update Certificate Assignment** button to select a certificate.

12. Select the certificate (Figure 8-52) you created earlier, and click **Assign New Certificate**.

	Certificate	Common name
<input checked="" type="radio"/>	Server certificate for Websphere SSL	Websphere SSL
<input type="radio"/>	Server Certificate for SSL	wasssl

Figure 8-52 Select certificate

13. You get the confirmation message shown in Figure 8-53. Click **Cancel** to exit.

Message The certificate was assigned to the application.

Application type: Server  
Application ID: QIBM\_HTTP\_SERVER\_AVN01HTTP  
Application description: QIBM\_HTTP\_SERVER\_AVN01HTTP

Figure 8-53 Confirmation the server certificate for SSL was assigned to the HTTP server instance

14. Return to the browser instance that holds your HTTP server configuration, and restart the HTTP server instance so that the certificate is picked up.

## 8.4.5 Testing the SSL configuration

Now that the necessary configuration is complete, all that remains is to verify the end-to-end SSL connection that we created in this chapter:

1. Verify that the SSL configuration is working correctly using the Snoop servlet. Enter the following URL in a Web browser (notice the HTTPS protocol and new port number 443):  
`https://<HTTP_system_hostname>:<port>/snoop`
2. You should see the warning message about accepting a new server certificate. Accept the certificate, and click **OK** (remember, we use Firefox for testing). If you receive another warning message, click **OK**. The browser displays the Snoop servlet result.

**Note:** You now see the padlock icon in your Web browser status bar. The secure communication is now *end-to-end* between Web browser, Web server, and WebSphere Application Server.

Now you should see the changed port (*Server port* parameter; the default value is 443) entry for the connection to the Web server. We also see, in Figure 8-54, that the communication is now SSL-encrypted for both connections: Web browser to Web server and Web server to WebSphere Application Server.

**HTTPS Information:**

Cipher Suite	SSL_RSA_WITH_RC4_128_MD5
--------------	--------------------------

**Request attributes:**

javax.servlet.request.cipher_suite	SSL_RSA_WITH_RC4_128_MD5
javax.servlet.request.key_size	128
com.ibm.websphere.servlet.uri_non_decoded	/snoop

Figure 8-54 Snoop servlet with 128-bit encryption from Web browser to WebSphere Application Server





## Performance monitoring and tuning

In this chapter, we provide performance tips to help you obtain the best possible results from your application and the hardware on which it is running. We also point you to the location of system values and other areas of interest to ensure that you have enough capacity to function efficiently in your environment.

During runtime, performance can also be impacted by factors other than your application's code and the hardware on which it is running. Other core infrastructure components that can affect performance include:

- ▶ Topology
- ▶ Clients
- ▶ Network
- ▶ Servers

Maintaining expected application runtime performance requires that you understand, plan, and closely manage the performance settings of all of your core infrastructure components.

For more information about performance aspects, including information about other core infrastructure components, refer to *Maximum Performance with WebSphere Application Server V5.1 on iSeries*, SG24-6383. Despite the fact that this IBM Redbooks publication is based on WebSphere Application Server V5.1, most of the recommendations are true for Version 6.1.

**Important:** Prior to reading this chapter, you should understand that every environment is different. The performance tips that we recommend might show immediate results for some, but might not be as effective for others. That is where the system administrator must decide and make the proper modifications based on your application and environment. Ultimately no-one knows your environment as well as you.

## 9.1 Performance checklist

In this section, we provide a task-based approach to getting the most out of your current system environment and identifying areas that may need further investigation.

### 9.1.1 Server hardware resources

One of the first areas to focus on is the server configuration on which your application is hosted. You must verify that the server has sufficient resources to accommodate the existing workload before tuning any other areas. At the same time, consider and project any future growth.

Java and WebSphere Application Server environments are typically known to be memory intensive with regard to the amount of memory they require to run efficiently, compared to traditional host applications. We recommend that when you select an IBM System i model to host your Java and WebSphere Application Server applications, look for models with higher CPU clock speeds (measured in gigahertz) as well as higher commercial processing workload (CPW). If your System i platform is dedicated to Java and WebSphere Application Server activity only, we recommend that you use a server with no interactive features.

We discuss hardware requirements for WebSphere Application Server in detail in Chapter 2, “Planning for WebSphere Application Server installation” on page 17.

#### Use the latest server model

The common recommendation for almost any environment is to use the latest hardware. Java and WebSphere Application Server workloads are CPU and memory intensive. Each piece of *new hardware* comes with faster CPUs, memory, and CPU cache. These updates can significantly improve the performance of WebSphere Application Server and Java applications.

#### Memory and cache

Java and WebSphere Application Server applications require more memory (main storage) than traditional green-window applications. Insufficient memory can lead to a number of problems and can cause increased CPU and disk usage (if the server has to page to disk), which in turn results in poor application performance.

We highly recommend that you have a server with a level 2 (L2) cache. The bigger the L2 cache is, the better your results are. To enable smaller-sized customers to run a WebSphere Application Server workload, IBM offers the Processor Accelerator on entry models.

#### Disk Input/Output service times

As with any system workload, it is important to make sure that you do not have a bottleneck that is caused by your disk Input/Output subsystem. Increased disk service times can create a domino effect and can eventually result in degraded performance.

For more information, refer to 9.2.1, “Disk configuration” on page 298

### 9.1.2 Applying the latest PTFs

Run the latest operating system version or release with the latest PTFs that are applied to the system. Although there is a balance that must be maintained between keeping a stable system and continually updating to a later level, we advise that you at least review the fix levels you are on every few months.

For performance purposes, IBM frequently adds Java and WebSphere fixes during the course of a release. As a result, it is important to apply the latest PTFs to all of the installed i5/OS products. We recommend the following:

- ▶ The latest operating system level
- ▶ The latest cumulative PTFs
- ▶ The latest Java group PTFs
- ▶ The latest DB2 UDB for iSeries group PTFs
- ▶ The latest HTTP group PTFs
- ▶ The latest WebSphere group PTFs

Refer to 3.6, “Installing the latest recommended WebSphere Application Server fixes” on page 53 for more information about PTF installation.

### 9.1.3 Isolating the WebSphere Application Server workload

By default, the WebSphere Application Server workload runs in the \*BASE memory pool, which means that it must share memory resources with other workloads that are running on this system.

If you have a mixed application environment on your system, we often recommend that you create a separate memory pool for your WebSphere Application Server workload, which allows you to better manage the memory utilization for WebSphere Application Server.

Refer to 9.2.3, “Isolating the WebSphere Application Server workload” on page 303 for more information about changing the memory pool configuration on your system.

### 9.1.4 System values for an optimum operating system environment

Start looking for tuning opportunities at the operating system level. Tuning at this level usually provides good gain with little pain. Often a simple setting change can produce favorable results. Table 9-1 contains the recommended system value settings.

Table 9-1 Recommended system value settings

System value	Description	Recommended setting
QPRCMLTTSK	Allows more than one set of task data on each CPU	1 or 2 on POWER5™ processor-driven systems
QTHDRSCADJ	Determines if the system will make adjustments to the affinity of threads	1
QTHDRSCAFN	Specifies whether or not secondary threads have affinity to the same group of processors	Group: *NoGroup Level: *Normal
QMAXACTLVL	Limits the number of threads that can compete at the same time for memory and processors	*NOMAX or large value
QPFRADJ	Specifies whether the system adjusts values automatically for maximum number of active jobs and pool sizes	0 or 3 with pool limits set

**Tip:** Even though the recommendation is to change QPFRADJ to 0 to turn off automatic adjustment, sometimes it is worthwhile to:

- ▶ Record the pool size and activity levels.
- ▶ Change QPFRADJ to a value of 2 while the system is under a stable load.
- ▶ Leave it for some time until the automatic adjust arrives at fairly stable levels to get a starting point for your pool and activity levels.
- ▶ Change QPFRADJ back to 0, so that you can fine-tune the system manually.

You could also change QPFRADJ to level 3, so that the system continues to automatically make adjustments, but in this case, look at setting minimum limits for the memory pools as we describe in 9.2.3, “Isolating the WebSphere Application Server workload” on page 303.

### 9.1.5 System wide performance-related commands

Using the i5/OS commands that we list in this section gives you a good overview of how the system is generally performing. They are generally useful for getting a quick snapshot of performance related information. Use these commands to monitor the system and to determine if something “unusual” happens.

If there is a performance issue, these commands can give you a general idea of what type of problem you are dealing with and help you to get an idea of what to look for next:

- ▶ **WRKACTJOB**
  - Use this command to review and change the attributes and resource utilization of the jobs on the system.
  - Refer to 9.2.2, “Using system commands” on page 299 for more details.
- ▶ **WRKSYSSTS**
  - This command provides an overview of current system activity. Specifically, it displays the number of jobs in the system and storage pool utilization information. It allows you to monitor and change system pool characteristics.
  - Refer to “WRKSYSSTS” on page 300 for more details.
- ▶ **WRKDSKSTS**
  - With this command, you can monitor the performance information and attributes for the system disk units.
  - Refer to 9.2.1, “Disk configuration” on page 298 for more details.
- ▶ **WRKSYSACT**
  - This command is only available if you have licensed program 5722-PT1 installed; however, it is very useful to display information about the most active jobs and tasks that are currently running on the system.
  - Refer to “WRKSYSACT” on page 303 for more details.

## 9.1.6 Choosing a JVM to use for best performance

Starting in IBM i5/OS Version 5 Release 4, two JVMs are available:

- ▶ The Classic JVM, which IBM introduced in 1998 on the IBM AS/400 platform, is a 64-bit JVM. The Classic JVM includes support for the Java Software Development Kit (SDK) 1.3, 1.4, and 1.5 (Java 5.0).
- ▶ An entirely new JVM, called IBM Technology for Java VM (32-bit) is also available from i5/OS V5R4. The new JVM currently supports JDK 1.5 (Java 5.0) and offers significant performance improvements for certain types of applications.

With WebSphere Application Server Version 6.1 running on i5/OS V5R4, you can keep the default option of using the IBM Developer Kit V5.0 (Classic) JVM or instead use IBM Technology for Java VM. There are variations in performance tool support for each JVM, for example, the DMPJVM and ANZJVM CL commands used with the Classic JVM are not compatible with IBM Technology for Java VM.

Refer to Chapter 11, “Running WebSphere Application Server with IBM Technology for Java VM” on page 379 for further information about determining which JVM you are running.

Whether switching WebSphere Application Server V6.1 to use 32-bit IBM Technology for Java VM is right for you depends mainly on the typical Java heap size in your environment. A general rule of thumb is that if WebSphere Application Server runs in Classic JVM with a heap size of less than about 5 GB, it should also run using IBM Technology for Java VM. If the heap size is more than 5 GB, WebSphere Application Server may not run properly using 32-bit IBM Technology for Java VM.

If you switch to IBM Technology for Java VM, be sure to test your application to ensure that any peaks in workload do not result in an `OutOfMemoryError`.

If you do not really know how much memory WebSphere Application Server uses, you have to obtain this information before you can make an informed decision about switching to IBM Technology for Java VM. You can use the DMPJVM command to find the memory footprint of the Classic JVM.

### Using the Dump Java Virtual Machine (DMPJVM) command to determine heap size

The DMPJVM command dumps information about the JVM for a specified job. It includes information about the classpath, garbage collection, and threads associated with the JVM. Complete the following steps to obtain DMPJVM information and to calculate the heap size of your WebSphere Application Server process:

1. Start the WebSphere Application Server profile.
2. Ramp up the workload that is running on the JVM.
3. Run the Dump Java Virtual Machine (DMPJVM) i5/OS command. You must have information about the job name, user name, and job number, which is usually your WAS instance job that is running in the QWAS61 subsystem, for instance, the command for WAS instance WAS61SVR with job number 186947 is:

```
DMPJVM JOB(186947/QEJBSVR/WAS61SVR)
```

4. A spool file is created on your default output queue. Look at the output section that is labeled *Garbage Collection*. When you run the DMPJVM command, the general rule is that the JVM requires the amount of memory that is indicated by the following formula:

$$\text{heap size} + \text{JIT heap size} + \text{JVM heap size} = \text{required JVM memory}$$

The JVM in this sample needs a minimum of approximately 1 GB of memory to provide a comfortable amount of space to process. The calculation is done as follows to determine the 1 GB recommendation as shown Figure 9-1:

$$347840 + 144096 + 242968 = 734094 \text{ KB}$$

```
.....  
. Garbage Collection .  
.....  
Garbage collector parameters  
  Initial size: 98304 K  
  Max size: 240000000 K  
Current values  
  Heap size: 347840 K  
  Garbage collections: 27  
Additional values  
  JIT heap size: 144096 K  
  JVM heap size: 242968 K  
  Last GC cycle time: 310 ms  
.....
```

Figure 9-1 Dump Java Virtual Machine (DMPJVM) output

For more information about the DMPJVM command, refer to the System i Information Center, V5R4 at the following link:

<http://publib.boulder.ibm.com/infocenter/iseriess/v5r4/index.jsp>

**Attention:** DMPJVM does hold the job briefly while it takes a snap-shot of the JVM. On rare occasions, with large JVMs, this can cause a performance problem that could require a JVM restart to recover.

**Note:** If the DMPJVM command does not produce any output, your interactive job might have terminated your interactive job. Check the Default wait time of your job using the CHGJOB command, which has a default value of 30 seconds. You might want to try increasing this to 300 seconds to give the command sufficient time to complete.

### 9.1.7 Analysis and tuning for the Classic JVM

The behavior of running the Classic JVM on the System i5 platform is unique, for instance, the initial heap size is more accurately called the Garbage Collector (GC) threshold. Whenever the heap grows to a size larger than the value that is specified by the initial heap size, the Garbage Collector runs asynchronously.

Therefore, increasing this value makes garbage collection occur less frequently and allows the heap to grow larger between collections, which, in turn, makes each GC cycle take longer because it must scan more memory. Setting the threshold to its optimal value involves finding the right balance between the frequency that the collector runs and the heap size. If it is set too low, the GC runs too frequently, which results in wasted CPU cycles. Setting it too high allows the heap to grow too large, which can result in a higher cache miss ratio and increased paging.

The maximum heap size limits the size of the Java heap to a specific size. You should almost never change the maximum size from the \*NOMAX default value.

When an application requests an object and the JVM has to allocate more memory in the Java heap to contain the object, the JVM ensures that the allocation does not cause the Java heap to exceed the maximum size setting. If the JVM cannot allocate the additional memory, the garbage collector runs synchronously to collect unused space within the heap. In the case of a synchronous garbage collection, all the Java threads have to stop for the period of the collection, which is not as efficient as the asynchronous collection that occurs normally. If the JVM still cannot allocate the object after the synchronous garbage collection, a *java.lang.OutOfMemory* exception occurs.

The optimum value for the heap size depends on the environment and the application. The trick to tuning the heap size is to balance the frequency and the duration of garbage collection cycles.

There are many ways that you can analyze the performance of WebSphere Application Server running on Classic JVM. In 9.3, “Classic JVM tools” on page 308, we review the most common tools.

### 9.1.8 Analyzing and tuning for IBM Technology for Java VM

Although IBM Technology for Java VM is new to i5/OS, it is essentially the same JVM that was available earlier on other platforms, such as Windows and AIX®, for example. Because of this, the same tools and knowledge are applicable across platforms.

For details of suggested tools to use, refer to 9.4, “IBM Technology for Java VM tools” on page 311.

For detailed information about IBM Technology for JVM, refer to the Book *Diagnostic Guide IBM Developer Kit and Runtime Environment, Java 2 Technology Edition, Version 5.0* SC34-6650-01, which covers in depth information for all system platforms and is available at:

<http://download.boulder.ibm.com/ibmdl/pub/software/dw/jdk/diagnosis/diag50.pdf>

We also recommend that you review Chapter 8 of the IBM Redbooks publication *IBM Technology for Java Virtual Machine in IBM i5/OS*, SG24-7353.

### 9.1.9 WebSphere queuing tips

WebSphere Application Server establishes a queuing network, which is a group of interconnected queues that represent various components. They are represented in the simplified example in Figure 9-2 on page 296.

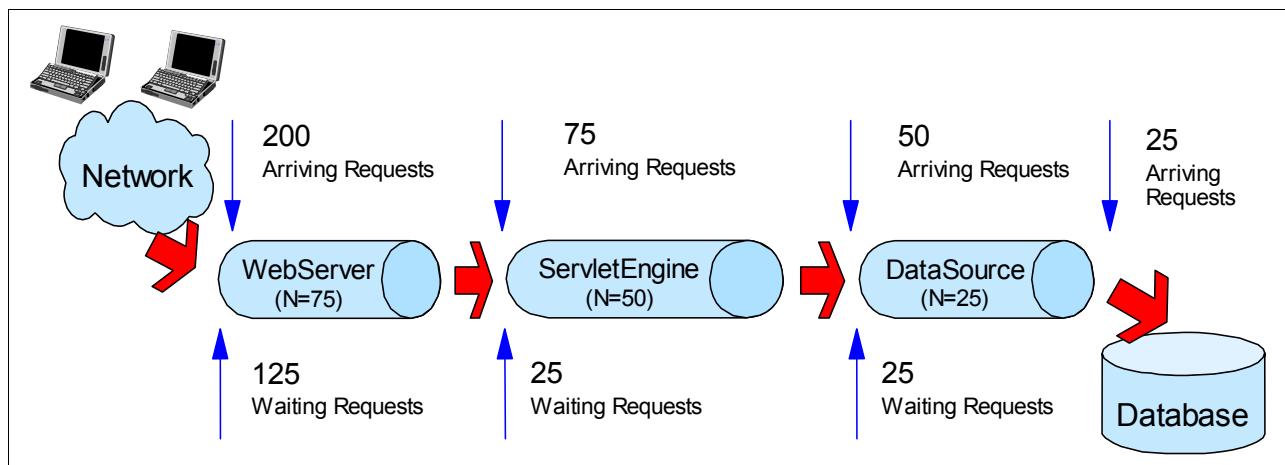

Figure 9-2 WebSphere Application Server queuing network

### Number of requests in WebSphere Application Server queues

In general, requests wait in the network in front of the Web server, rather than waiting in WebSphere Application Server.

You can specify that the queues that are furthest upstream, or closest to the client, are slightly larger, and queues further downstream or furthest from the client are progressively smaller.

### Determining when the system capabilities are maximized

Having too many threads of execution in WebSphere Application Server at the same time can be detrimental to optimum performance. Therefore, it is wise to ramp up the workload with large queues at the beginning. When you know that the workload is saturating the machine, back down the queues to fit this saturation point.

### Decreasing queue sizes while moving downstream from the client

The number of concurrent users at the throughput saturation point represents the maximum concurrency of the application, for example, if the application saturates WebSphere Application Server at 50 users, 48 users might produce the best combination of throughput and response time. To help determine the number of concurrent users, view the *Servlet Engine Thread Pool* and *Concurrently Active Threads* metric in Tivoli Performance Viewer (TPV).

Tivoli Performance Viewer provides information to help tune your WebSphere environment for optimal performance. In WebSphere Application Server V6.1, you can use the WebSphere Administrative Console to access TPV. Refer to 9.6, “Using Tivoli Performance Viewer with WebSphere Application Server” on page 332 for details about using Tivoli Performance Viewer.

### Adjusting queue settings to correspond to access patterns

In many cases, only a fraction of the requests that pass through one queue enter the next queue downstream. In a site with many static pages, the Web server fulfills a number of requests; thus, it is not necessary to pass these requests to the Web container that is running inside WebSphere Application Server. In this situation, the Web server queue can be significantly larger than the Web container queue.

## 9.1.10 Database tuning

Opening and closing database connections is a resource-consuming step that you need to keep to a minimum, if possible. In a WebSphere environment, IBM recommends that you manage database connections through a data source to open and store database connections in a pool. If the user opens a connection through the data source, WebSphere Application Server then allocates a connection from the pool. Through the WebSphere Administrative Console, you can use Tivoli Performance Viewer to monitor database connection pools. Refer to 9.6, “Using Tivoli Performance Viewer with WebSphere Application Server” on page 332 for more information.

### SQL performance diagnosis

The performance of your WebSphere application is also affected by any database that your application must access. If, for instance, you see that the database server jobs QSQSRVR or QZDASOINIT account for a large amount of CPU, this may indicate that you investigate your database access.

The SQL Performance Monitor is part of the iSeries Navigator. It is useful to identify any expensive SQL queries and to investigate what is causing the queries to take a long time to execute. It allows you to:

- ▶ Drill down to individual queries
- ▶ Determine if any indexes are advised
- ▶ Recognize any full opens being performed

SQL Performance Diagnosis is beyond the scope of this book. For detailed information in this area, refer to the IBM Redbook *SQL Performance Diagnosis on IBM DB2 Universal Database for iSeries*, SG24-6654

## 9.1.11 Stress test to identify system thresholds and bottlenecks

When you experience performance related issues, perform some load and stress testing to help identify system thresholds and bottlenecks. The following load generating tools, among others, can help simulate your workload in order to produce consistent results:

- ▶ *IBM Rational Performance Tester* is an enterprise-level test automation tool for performance analysis of Web applications.
- ▶ *Apache JMeter* is a 100% pure Java desktop application that is designed to load test functional behavior and to measure performance.
- ▶ *Mercury LoadRunner* is probably the most popular software in this list. It is used as the industry-standard load testing product for predicting system behavior and performance.
- ▶ Open source *OpenSTA* is a distributed software testing architecture, which is based on CORBA, that can generate realistic, heavy loads that simulate the activity of hundreds to thousands of virtual users.
- ▶ *SourceForge Grinder* is a pure Java load-testing framework.

For more information, including information about other core infrastructure components, refer to the IBM Redbooks publication *Maximum Performance with WebSphere Application Server V5.1 on iSeries*, SG24-6383.

## 9.2 System i configuration

The areas in this section are related to the overall system environment that WebSphere Application Server is running in. This is a good place to start to identify what if any problems you have. On a regular basis, you can use the commands that we discuss in this section just to do a general status check of your environment.

### 9.2.1 Disk configuration

As with any system workload, it is important to have sufficient Input/Output bandwidth. At the high level, this is directly affected by the number of disk arms and a sufficient amount of free disk space. When you have less than 50% of free disk space, disk service times start to increase, as disk space fragmentation increases.

For good performance, keep your disk arm utilization under 50% and the disk IOP utilization under 60%. Increasing the amount of read/write cache on your disk controller also improves disk performance.

The best way to view peak disk arm utilization is to use Collection Services, which is beyond the scope of this section. Alternatively, you can get a quick estimate about whether disk utilization is a problem by using the following steps, assuming that you are running a Java or WebSphere Application Server workload:

1. Start WebSphere Application Server.
2. Start the workload for the application, and produce stress on the application server for a period of about 10 minutes.
3. Run the Work with Disk Status (WRKDSKSTS) command.
4. Press the F10 (Restart statistics) key and then the F5 key every 5 to 10 seconds.
5. Look at the Busy column. A single disk arm that is at 50% busy (or more) during the period can indicate a sign that the disk arms are a performance bottleneck. Figure 9-3 on page 299 shows an example of the WRKDSKSTS command output.

Work with Disk Status										RCHAS60
Elapsed time: 00:00:09										08/03/06 17:00:49
Unit	Type	Size (M)	% Used	I/O Rqs	Request Size (K)	Read Rqs	Write Rqs	Read (K)	Write (K)	% Busy
1	4326	30769	30.1	26.7	4.8	2.9	23.8	5.0	4.7	11
2	4326	30769	14.2	43.7	35.0	15.3	28.3	89.7	5.3	16
3	4326	30769	14.2	52.8	19.1	7.4	45.4	106.4	4.8	16
4	4326	30769	14.2	31.0	13.7	6.3	24.6	49.7	4.5	11
5	4326	30769	14.2	50.3	31.8	15.6	34.7	92.5	4.4	5
6	4326	30769	14.2	46.0	21.5	13.3	32.7	62.1	5.0	11
7	4326	30769	14.2	63.1	21.2	15.8	47.2	71.1	4.5	5
8	4326	30769	14.2	60.3	31.2	24.3	36.0	70.5	4.7	11
9	4326	30769	14.2	47.6	31.6	17.5	30.0	78.1	4.3	5
10	4326	30769	14.2	30.1	52.0	18.8	11.2	80.2	4.6	5
11	4326	30769	14.2	47.6	27.4	14.3	33.3	80.1	4.8	5
12	4326	30769	14.2	45.5	34.0	16.2	29.2	86.8	4.7	5
13	4326	30769	14.2	48.0	42.1	18.1	29.9	103.7	4.8	0

More...

Command  
====>  
F3=Exit F5=Refresh F12=Cancel F24=More keys

Figure 9-3 Work with Disk Status display

**Important:** You can generate the workload using a stress testing tool or using the production workload. Do not start a test workload in your production environment because it will affect your existing applications and performance. If you must use a test tool workload, select a time when the system is not heavily used.

## 9.2.2 Using system commands

There are several i5/OS system commands that you can use to perform real time sampling to understand processor, memory, and disk usage on your System i server. This can help you identify areas for improvement or if there is system behavior that is indicative of a performance issue.

### WRKACTJOB

The Work with Active Jobs (WRKACTJOB) display shows the performance and status information for jobs that are currently active on the system. All information is gathered on a per-job basis. The jobs are grouped under the subsystem in which they are running.

You can use WRKACTJOB to determine which jobs are using the most CPU on the system:

- ▶ Java Virtual Machine
- ▶ Database jobs (QSQRV and QZDASOINIT)
- ▶ Other

Perform the following steps when you want to see which job has the largest amount of threads running:

1. Enter the WRKACTJOB command.
2. Press F11 continuously until you see the Threads column.
3. Move the cursor onto the Threads column.
4. Press F16 to rearrange the jobs according to the column, as shown in Figure 9-4.

```

                                Work with Active Jobs                                RCHAS60
                                                                08/09/06 14:24:02
CPU %:    24.5      Elapsed time:  00:00:10      Active jobs:  341

Type options, press Enter.
  2=Change  3=Hold  4=End  5=Work with  6=Release  7=Display message
  8=Work with spooled files  13=Disconnect ...

Opt  Subsystem/Job  User      Number  Type  CPU %  Threads
-----
   1  TRADE51      QEJBSVR   107841  BCH   14.0   151
   2  QZLSFILET    QUSER    104960  PJ     .0     50
   3  ADMIN        QTMHHTTP 105087  BCH     .0     47
   4  ADMIN        QEJBSVR   105086  BCH     .0     40
   5  QCPMGTAGT    QCPMGDIR 104921  BCH     .0     32
   6  QYPSJSVR     QYPSJSVR 104871  BCH     .0     28
   7  QYPSFRCOL    QSYS     105044  BCH     .0     26
   8  ADMIN        QTMHHTTP 105088  BCI     .0     24
   9  QINTER       QSYS     104758  SBS     .0     22

                                                                More...

Parameters or command
====>
F3=Exit  F5=Refresh  F7=Find  F10=Restart statistics  F11=Display status
F12=Cancel  F17=Top  F18=Bottom  F23=More options  F24=More keys

```

Figure 9-4 Work with Active Jobs showing maximum threads

## WRKSYSSTS

WebSphere applications are sensitive to the amount of memory that is available to the JVM. To run optimally, Java workloads typically require more memory than traditional workloads. If a Java workload does not have adequate memory, the response time often degrades. To determine if an application has reached this state, issue the i5/OS Work with System Status command, and look at the paging rates in the memory pool that is running the JVM. The acceptable paging rate varies widely on different hardware configurations. Regardless, if the JVM is the only job running in the pool and the workload has adequately warmed up, rates under 50 non-database (Non-DB) pages per second is typical as shown in Figure 9-5 on page 301.

```

Work with System Status
                                RCHAS60
                                08/09/06 14:45:04
% CPU used . . . . . :      23.2   Auxiliary storage:
% DB capability . . . . . :      5.6   System ASP . . . . . :    492.3 G
Elapsed time . . . . . :    00:00:12  % system ASP used . . :    16.0596
Jobs in system . . . . . :     9916   Total . . . . . :      597.8 G
% perm addresses . . . . . :     .009  Current unprotect used :    9676 M
% temp addresses . . . . . :     .019  Maximum unprotect . . :   11452 M

Type changes (if allowed), press Enter.

System   Pool   Reserved   Max   -----DB-----   ---Non-DB---
Pool   Size (M)   Size (M)   Active   Fault   Pages   Fault   Pages
  1     1394.55   725.42   +++++   .0     .0     .0     .0
  2     26997.59   2.73     390     .6     .8     1.7    1.7
  3     3193.59   .00      799     .0     .0     .0     .0
  4         .25   .00      5       .0     .0     .0     .0
  5      900.00   .73      50      .0     .0     25.3   25.3

Bottom

Command
====>
F3=Exit   F4=Prompt   F5=Refresh   F9=Retrieve   F10=Restart   F12=Cancel
F19=Extended system status   F24=More keys

```

Figure 9-5 Work with System Status display

High page faulting rates and high disk utilization are indicators that the amount of memory is not adequate for the workload. Plan to increase the amount of available memory in the pool to gain the expected application performance.

As a rough guide, the total page faulting rate (the sum all of the DB Fault and Non-DB Fault values added across all the pools) should be below the value that results from this equation:

View the data in the *DB Fault and Pages* and *Non-DB Fault and Pages*. The data in the Non-DB columns is of interest for performance tuning.

$$100 \times (\%CPU \text{ used} / 100) \times \text{number of processors in this partition} = \text{total page faulting rate}$$

If we use the data shown in Figure 9-5, the calculation is:

$$100 \times (23.2 / 100) \times 2 = 46.4 \text{ faults per second}$$

For a more detailed discussion, refer to Chapter 19, "Miscellaneous Performance Information", which provides recommendations about page fault rates, in *iSeries Performance Capabilities Reference i5/OS Version 5, Release 4, SC41-0607*, at the following Web address:

<http://publib.boulder.ibm.com/InfoCenter/iseriess/v5r4/topic/books/sc410607.pdf>

### Activity Level

One of the most important parameters on the WRKSYSSTS display is the information about thread transitions. This information is presented in the three right-most columns when you press F11 (Display transition data). See Figure 9-6 on page 302.

```

Work with System Status
                                08/17/06 16:36:15
                                RCHAS60
% CPU used . . . . . : 37.0   Auxiliary storage:
% DB capability . . . . . : .0   System ASP . . . . . : 492.3 G
Elapsed time . . . . . : 00:00:12 % system ASP used . . : 16.2926
Jobs in system . . . . . : 6504   Total . . . . . : 597.8 G
% perm addresses . . . . . : .009   Current unprotect used : 11687 M
% temp addresses . . . . . : .022   Maximum unprotect . . : 12953 M

Type changes (if allowed), press Enter.

System   Pool   Reserved   Max   Active->   Wait->   Active->
Pool     Size (M)   Size (M)   Active   Wait      Inel      Inel
  1     1394.55   725.55   +++++   9.3       .0       .0
  2     25347.59   3.84     390     9065      .0       .0
  3     3193.59    <.01     799     46.5      .0       .0
  4         .25     .00      5       .0        .0       .0
  5     2000.00    .10      50     8823      .0       .0

Bottom

Command
====>
F3=Exit   F4=Prompt   F5=Refresh   F9=Retrieve   F10=Restart   F12=Cancel
F19=Extended system status   F24=More keys

```

Figure 9-6 Thread transitions

In Figure 9-6, the data in the *Active - Wait* column represents the number of the thread transitions per minute from active to wait state. This is normal behavior when, for example, a thread waits for completion of a disk read operation.

The data in the *Wait - Inel* column represents the number of thread transitions per minute from wait to ineligible state. An *ineligible state* is when a thread is ready to continue its execution, but must wait for the number of active threads in the memory pool to fall below the maximum activity level or for a thread to reach the end of its time slice.

The data in the *Active - Inel* column represents the number of thread transitions per minute from active to ineligible state.

Your goal is to have no transitions (0) in the Wait-Inel and Active-Inel columns. In this environment, you do not want any barriers between threads and the pool resources, which increasing the activity level achieves.

To change the activity level, type the new value in the Max Active column and press Enter. In our case, you would change the Max Active for pool number 5. If you are not sure which pool it is, press F11 again to display the names of the pools. If the automatic performance adjuster is not enabled, the new value is used while the subsystem is active.

However, there is a trade-off that is associated with increasing the activity level of a system pool. As soon as you increase the activity level for the pool, more threads are eligible to share the pool's memory, which might create a situation where the allocated memory for the pool is not enough to satisfy all threads' needs. In this case, some data from memory must be moved to disk (*paging*), which increases the disk faulting rate (see 9.2.1, "Disk configuration" on page 298 for more information) and can create a situation known as *thrashing*, whereby the system spends a significant amount of time simply moving pages back and forth to disk,

rather than processing active jobs. For this reason, make sure that your memory allocation corresponds to the activity level of the shared pool.

## WRKSYSACT

The Work with System Activity (WRKSYSACT) display allows you to view performance data from a 5250 session in real-time fashion. It is the only command that shows how both jobs and tasks use the system resources. The output from this command is very useful in quickly identifying a badly-behaved task or job that is consuming excessive CPU cycles and disk I/O. It is also a good way to determine the current processing capacity in a partitioned environment.

**Restriction:** The WRKSYSACT command is only available if Licensed Program Product 5722-PT1 is installed.

Figure 9-7 shows an example of the Work with System Activity output, showing the internal IBM Trade6 application and associated database jobs.

Work with System Activity						RCHAS60			
						08/09/06 14:57:10			
Automatic refresh in seconds . . . . .						5			
Elapsed time . . . . .		00:00:10		Average CPU util . . . . .		30.4			
Number of CPUs . . . . .		2		Maximum CPU util . . . . .		30.9			
Overall DB CPU util . . . . .		2.2		Minimum CPU util . . . . .		29.8			
						Current processing capacity: 2.00			
Authorization Type . . . . .									
Type options, press Enter.									
1=Monitor job 5=Work with job									
						Total	Total	DB	
Opt	Job or Task	User	Number	Thread	Pty	CPU Util	Sync I/O	Async I/O	DB CPU Util
	QSQRVR	QUSER	108634	00000001	20	1.9	30	2147	1.1
	QSQRVR	QUSER	108649	00000001	20	1.9	23	2130	.7
	QSQRVR	QUSER	108650	00000001	20	1.7	23	1663	1.1
	TRADE6	QEJBSVR	107841	00000982	20	1.2	6	8	.0
	TRADE6	QEJBSVR	107841	00000988	20	1.2	6	2	.0
	QSQRVR	QUSER	104902	00000001	20	1.1	20	988	.8
	QSQRVR	QUSER	108655	00000001	20	1.1	21	1009	.0
						More...			
F3=Exit F10=Update list F11=View 2 F12=Cancel F19=Automatic refresh									
F24=More keys									

Figure 9-7 Work with System Activity display

### 9.2.3 Isolating the WebSphere Application Server workload

By default the WebSphere Application Server workload runs in the \*BASE memory pool, which means that it must share memory resources with other workloads that are running on the system.

If you have a mixed application environment on your system, we often recommend that you create a separate memory pool for your WebSphere Application Server workload, which allows you to better manage the memory utilization for WebSphere Application Server.

## Creating a memory pool

In i5/OS, all main storage can be divided into logical allocations called *memory pools*. A pool is a division of main or auxiliary storage (memory). The two types of memory pools in a system are:

**Shared memory pool** A pool in which multiple subsystems can run jobs in.

**Private memory pool** A pool in which only a single subsystem can run jobs.

Four memory pools are defined by default:

<b>*MACHINE</b>	The memory pool for i5/OS system jobs.
<b>*BASE</b>	The memory pool which contains all unassigned main storage on the system (all main storage that is not required by another memory pool) By default, the WebSphere Application Server workload runs in this pool.
<b>*INTERACT</b>	The interactive storage pool used for interactive jobs.
<b>*SPOOL</b>	The storage pool used for print spool writers.

To create a recommended separate memory pool for WebSphere Application Server subsystem jobs to run in:

1. Sign on to your system using a 5250 session.
2. Enter the Work with Shared Pool (WRKSHRP00L) command.
3. In the Work with Shared Pools display (Figure 9-8 on page 305), you can view the shared memory pools. Look for the next available shared memory pool. For the purpose of this example, we use \*SHRPOOL1:
  - a. In the Defined Size (M) column, set the desired amount of memory in MB. Another option you have here is that if you press F11 (Display tuning data) you can set a minimum size for the pool. This setting can be useful even if you have system value QPFRADJ set to 2 or 3, because you can still make sure that the WebSphere subsystem does not drop below a defined memory threshold and is not starved of memory.

**Attention:** The minimum memory requirement for WebSphere Application Server V6.1 is 768 MB. However we recommend that you increase the memory to at least 1 GB. In most cases, you must run workload tests to determine the correct amount of memory for your application usage pattern. For assistance on calculating the appropriate values for the Memory Pool size and Activity level, refer to “WRKSYSSTS” on page 300.

- b. In the Max Active column, set the desired activity level, and press Enter.
- c. Press F3 to exit this command display.

```

                                Work with Shared Pools
                                System:  RCHAS60
Main storage size (M) . . :      31935.99

Type changes (if allowed), press Enter.

Pool          Defined   Max   Allocated   Pool  -Paging Option--
              Size (M)  Active Size (M)   ID    Defined  Current
*MACHINE      1394.55  +++++  1394.55    1     *FIXED  *FIXED
*BASE         25347.59  390   25347.59   2     *FIXED  *FIXED
*INTERACT     3193.59  799   3193.59    3     *FIXED  *FIXED
*SPOOL        .25      5     .25         4     *FIXED  *FIXED
*SHRPOOL1     2000.00  300   2000.00    5     *FIXED  *FIXED
*SHRPOOL2     .00      0     .00         .     *FIXED
*SHRPOOL3     .00      0     .00         .     *FIXED
*SHRPOOL4     .00      0     .00         .     *FIXED
*SHRPOOL5     .00      0     .00         .     *FIXED
*SHRPOOL6     .00      0     .00         .     *FIXED

More...

Command
====>
F3=Exit  F4=Prompt  F5=Refresh  F9=Retrieve  F11=Display tuning data
F12=Cancel

```

Figure 9-8 Work with Shared Pools display

4. Enter the Change Subsystem Description (CHGSBSD) command to tell the QWAS61 subsystem in which WebSphere Application Server V6.1 runs, that it will be allocated to a new memory pool, as shown in Figure 9-9:

```
CHGSBSD SBSD(QWAS61/QWAS61) POOLS((2 *SHRPOOL1))
```

```

                                Change Subsystem Description (CHGSBSD)

Type choices, press Enter.

Subsystem description . . . . . > QWAS61      Name
Library . . . . . > QWAS61                  Name, *LIBL, *CURLIB
Storage pools:
Pool identifier . . . . . > 2                1-10, *SAME
Storage size . . . . . > *SHRPOOL1          Number, *BASE, *NOSTG...
Activity level . . . . .                    Number
      + for more values
Maximum jobs . . . . . *SAME                0-1000, *SAME, *NOMAX
Text 'description' . . . . . *SAME

Bottom
F3=Exit  F4=Prompt  F5=Refresh  F10=Additional parameters  F12=Cancel
F13=How to use this display  F24=More keys

```

Figure 9-9 Change Subsystem Description display

- Change the Routing Entry for the QWAS61 subsystem in order to direct the jobs to the newly created memory pool. Enter the following command (Figure 9-10):

```
CHGRTGE SBSD(QWAS61/QWAS61) SEQNBR(9999) POOLID(2)
```

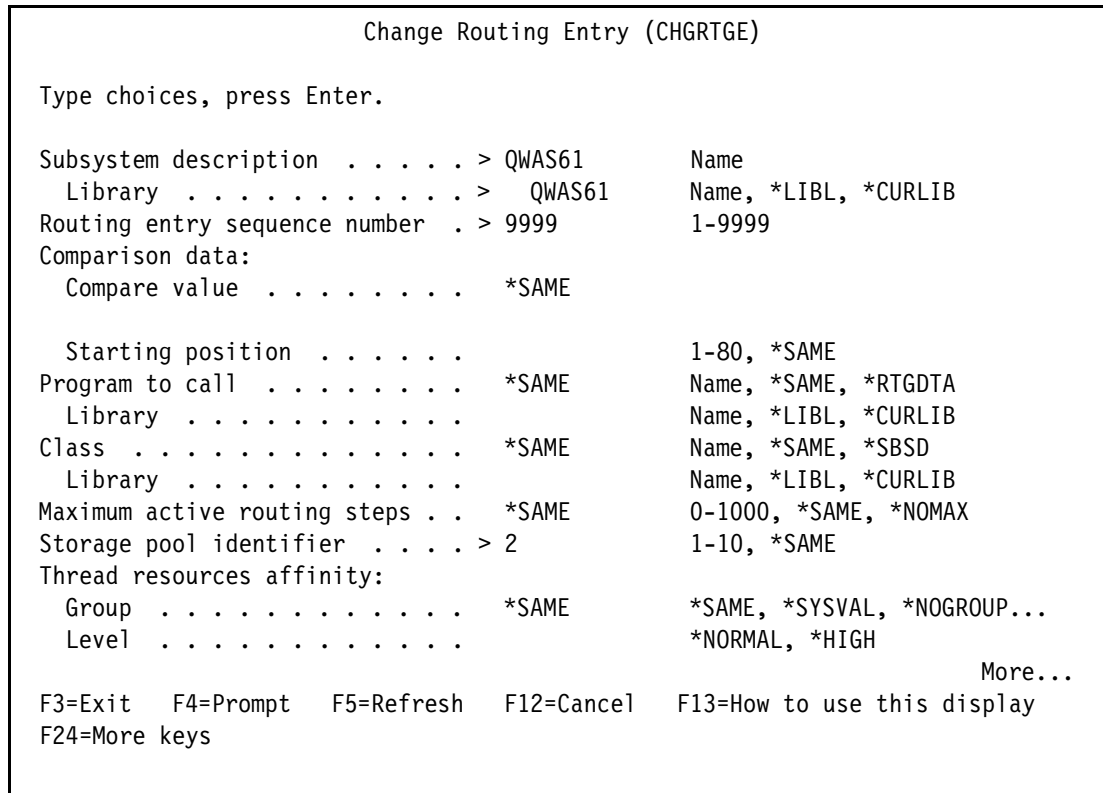

Figure 9-10 Change Routing Entry display

- Restart the QWAS61 subsystem by using the End Subsystem (ENDSBS) command followed by the STRSBS command.

The CHGRTGE command does not affect the jobs that are already active within a subsystem. It only affects the jobs that are started after the routing entry is changed. To direct all the jobs to the newly created memory pool, you must either end the subsystem and restart it, or stop and restart each application server.

**Attention:** If you have a production WebSphere Application Server instance running, it is best to select a time that does not impact the availability of the application or let maintenance restart it for you.

In WebSphere Application Server V6.1, there are a number of new command line options for the **startServer** command. Options such as **-sbs** allow you to specify which subsystem you want the server to start in. This can be advantageous, for instance, if you have both a production and development WebSphere Application Server profile, and you want them to run in separate subsystems.

## 9.2.4 Setting heap size for WebSphere Application Server

To modify the heap size used by the JVM in which WebSphere Application Server runs, complete the following steps:

- Start the WebSphere Administrative Console.

2. In the left navigation frame, expand **Servers**, and click **Application servers**.
3. Click the name link for your application server, which is **WAS61BELSS2** in our example.
4. In the next pane, expand **Java and Process Management**, and click **Process Definition** (see Figure 9-11).

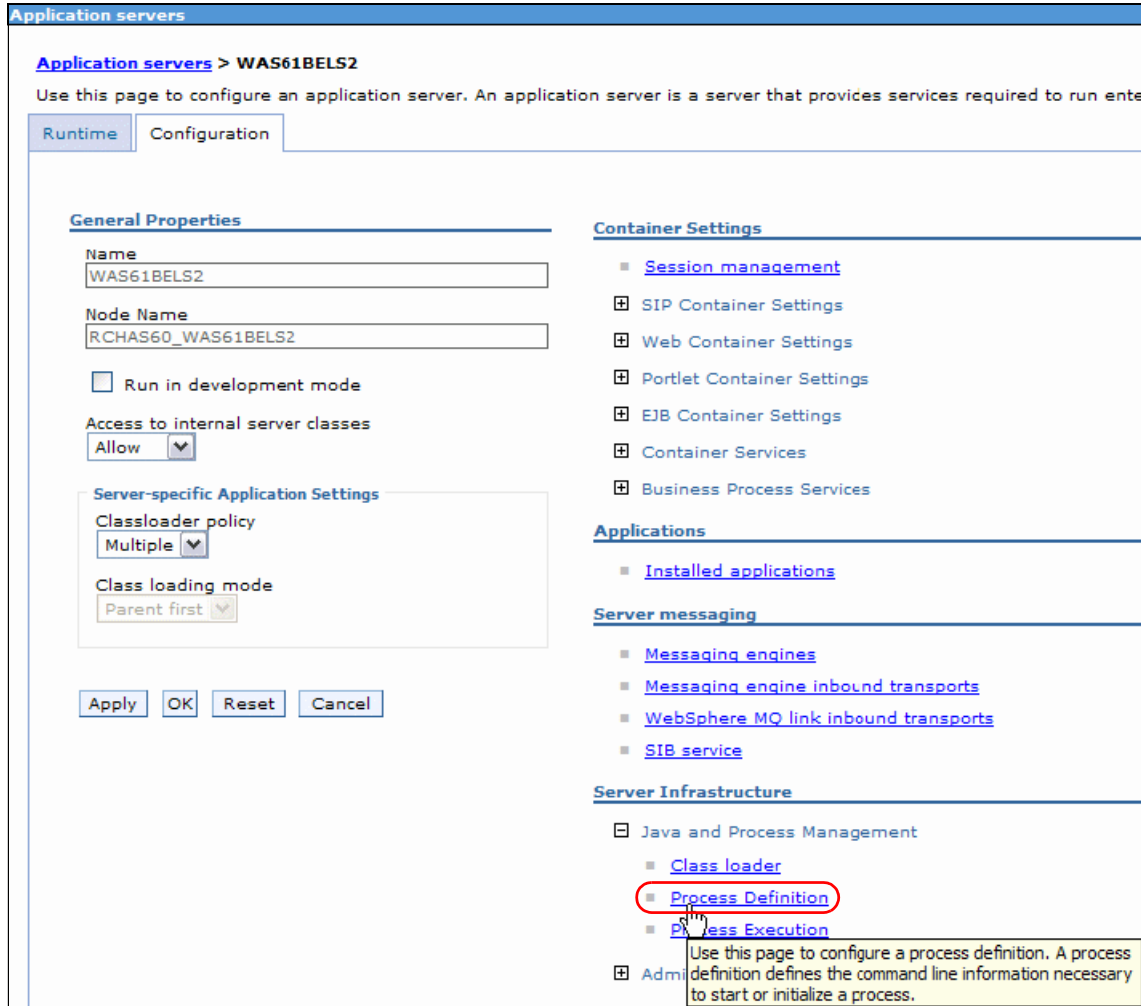

Figure 9-11 Process Definition

5. In the next window (Figure 9-12), under Additional Properties click **Java Virtual Machine**.

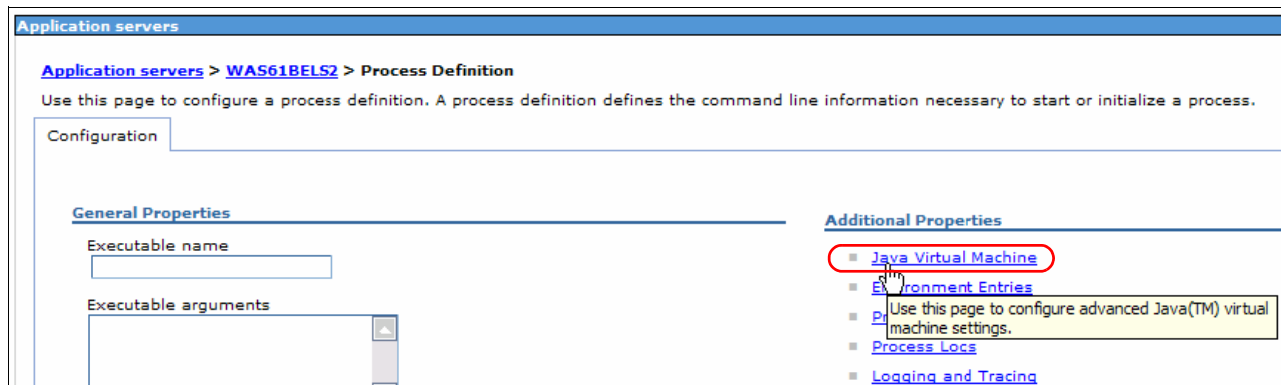

Figure 9-12 Java Virtual Machine settings

6. In the Java Virtual Machine window, under General Properties, in the Initial Heap Size field, type the desired value for the heap size in MB, as shown in Figure 9-13.

**Note:** If this is the first time that you are changing this value, the field is blank, which indicates that the default value is used.

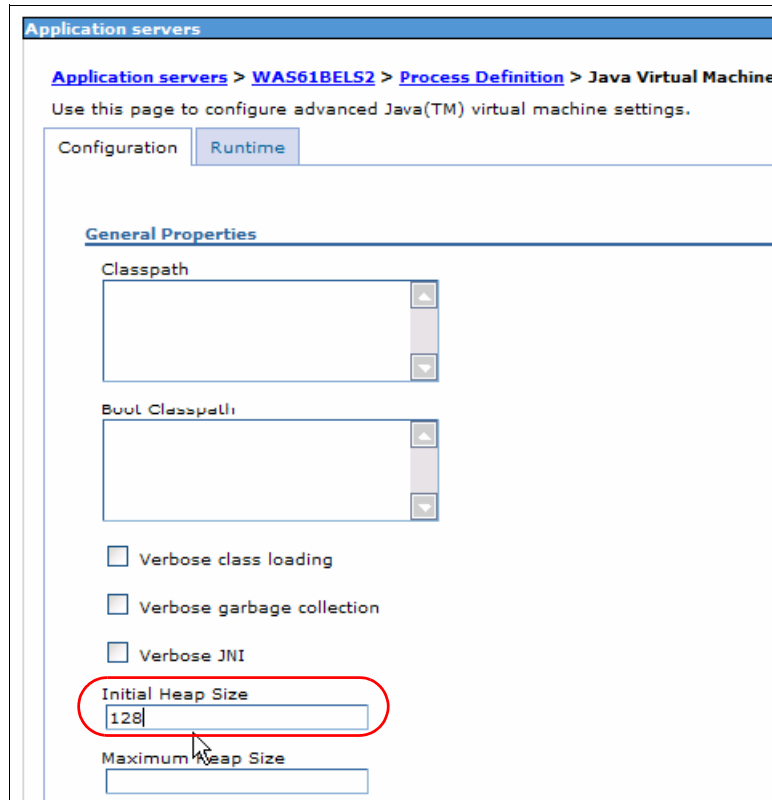

Figure 9-13 Java Virtual Machine Process Definition

7. Click the **Save** link at the top of the page to save your changes.
8. Log out from the console.
9. Restart your application server for the changes to take effect.

## 9.3 Classic JVM tools

The information in this section is intended to be applied to WebSphere Application Server profiles that are running on the Classic JVM. If you are using the IBM Technology for Java VM, then review 9.4, “IBM Technology for Java VM tools” on page 311.

### 9.3.1 Verbose Garbage Collection

Reviewing Verbose Garbage Collection (GC) output is a simple way to monitor garbage collection behavior. The output from this tool is useful for:

- ▶ Checking for object leaks
- ▶ Monitoring heap size
- ▶ Checking number of objects in the heap

- ▶ Observing frequency of Garbage Collection cycles
- ▶ Discovering length of Garbage Collection cycles

To turn on Verbose GC:

1. Navigate to the Java Virtual Machine Process definition, as shown in Figure 9-13 on page 308.
2. Select the **Runtime** tab at the top of the page.
3. Select the **Verbose garbage collection** option, as shown in Figure 9-14.

**Attention:** Use the verbose GC option only during debugging because depending on the application, there might be a slight impact to runtime performance.

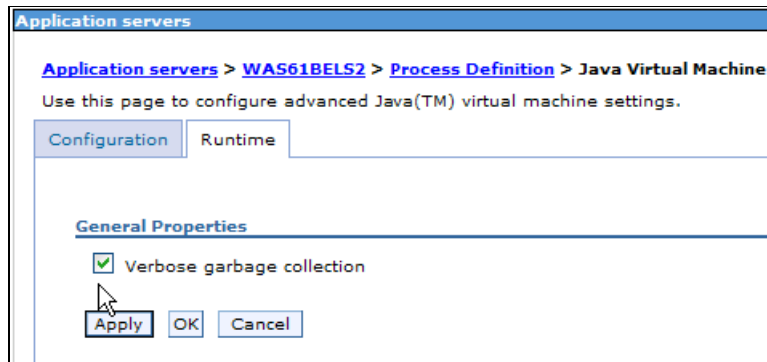

Figure 9-14 Turning on Verbose Garbage Collection

4. Click the **OK** button twice.
5. Make sure you click the **Save** link, as shown in Figure 9-15.

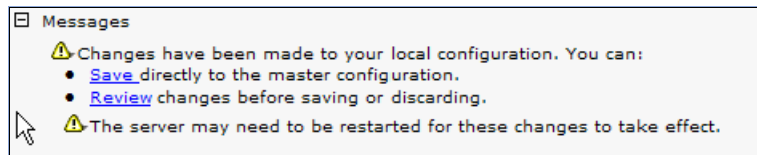

Figure 9-15 Save Configuration changes

**Tip:** Even though the message stated that the server may need to be restarted, we found that this was not necessary in the testing that we performed.

The Verbose GC output can, for Base edition at the default installation location, be found at:

`/QIBM/UserData/WebSphere/AppServer/V61/Base/profiles/instance_name/logs/server_name/native_stdout.log`

Example 9-1 shows a sample of verbose GC output.

*Example 9-1 verbose GC output*

```
GC 21: live objects 660435; collected objects 1322925; collected(KB) 112919.
GC 21: queued for finalization 0; total soft references 1835; cleared soft references 0.
GC 21: current heap(KB) 286816; current threshold(KB) 98304.
GC 21: collect (milliseconds) 5116.
```

GC 21: current cycle allocation(KB) 19920; previous cycle allocation(KB) 98334.  
GC 21: total weak references 645; cleared weak references 23.  
GC 21: total final references 2501; cleared final references 1001.  
GC 21: total phantom references 4; cleared phantom references 0.  
GC 21: total JNI global weak references 0; cleared JNI global weak references 0.

---

The following list explains the most important items in the verbose GC output:

- ▶ GC 21: The twenty-first garbage collection cycle since JVM started
- ▶ Live objects: Number of objects currently active in the JVM
- ▶ Collected objects: Number of objects collected during this cycle
- ▶ Collected (KB): Total size of the objects collected during this cycle
- ▶ Current heap (KB): The current heap size
- ▶ Current threshold (KB): The threshold value
- ▶ Collect (milliseconds): Elapsed time for this cycle
- ▶ Current cycle allocation (KB): Memory allocated since the current cycle began
- ▶ Previous cycle allocation (KB): Memory allocated since the last cycle began

### 9.3.2 DMPJVM

You can use the DMPJVM command to determine the approximate amount of memory that is required for a single Java virtual machine (JVM). It also provides similar information to verbose GC output, such as heap state and garbage collection activity, but the DMPJVM command does not require you to enable a JVM option through the WebSphere Administrative Console. See 9.1.6, “Choosing a JVM to use for best performance” on page 293 for an example of using the DMPJVM command.

### 9.3.3 Analyzing object growth using ANZJVM

One possible cause of a WebSphere Application Server JVM throwing `OutOfMemoryError` is a Java object leak, which means that over time, the application creates enough objects to cause the heap to grow larger than the amount of memory that is available. You can diagnose this by using the i5/OS Analyze Java (ANZJVM) command, which compares the number of objects for each class at two different points-of-time. Almost any leaking objects are evident in the ANZJVM output.

To analyze the object growth using ANZJVM:

1. Start the WebSphere Application Server profile.
2. Ramp up the workload that is running on the JVM.
3. Run the Analyze Java Virtual Machine (ANZJVM) i5/OS command. You must have information about the job name, user name, and job number. This would usually be your WAS instance job that is running in the QWAS61 subsystem. By default, the snapshot interval is 60 seconds. You can specify up to one hour. You can also specify various sorts of criteria. A good place to start is to specify `*SIZECHG` so that the information is sorted by the change in the amount of space that the objects use.
4. A spool file is created on your default output queue. The listing can be very long, but as it is in the sort order specified, the information that is required to identify problematic applications is typically in the first few pages of the printout. See Figure 9-16 on page 311 for an example.

```

.....
. GC heap information
.....
Loader
|   Number of pass one objects in the GC heap
|   |   Number of pass two objects in the GC heap
|   |   |   Change in the number of objects in the GC heap
|   |   |   |   Pass one object size (K)
|   |   |   |   |   Pass two object size (K)
|   |   |   |   |   |   Change in object size (K)
|   |   |   |   |   |   |   In global registry
|   |   |   |   |   |   |   |   Class name
|   |   |   |   |   |   |   |   |
0   5626   5689   63   153   155   2   NO   java/lang/Intege
0   92     147   55   3     5     2   NO   java/io/FileInpu
0   29     70    41   3     9     6   NO   com/ibm/ws/buffe
0   17540  17566   26   890   892   2   NO   java/util/Hashta
0   566    583   17   17    18    1   NO   [Ljava/nio/ByteB
0   7459  7472   13   445   446   1   NO   [Ljava/lang/Stri
0   13     25    12   0     0     0   NO   java/lang/String

```

Figure 9-16 Sample ANZJVM output showing increasing number of objects in the heap

## 9.4 IBM Technology for Java VM tools

The tools that we list in this section can only be used with IBM Technology for Java VM. If you are using the Classic JVM, you must use the tools that we discussed in 9.3, “Classic JVM tools” on page 308.

### 9.4.1 Verbose Garbage Collector output

IBM Technology for Java can also produce Verbose Garbage Collector output. You enable this in the same way as for Classic JVM, which we described in 9.3.1, “Verbose Garbage Collection” on page 308. Although the method to enable verbose GC is the same, the output from IBM Technology for Java VM is in XML format and is not as easily interpreted as the Verbose GC output from the Classic JVM.

The Verbose GC output from IBM Technology for Java VM is found in the `native_stderr.log` file in your profile’s log directory by default. For our example Trade6 profile, this is:

```
/QIBM/UserData/WebSphere/AppServer/V61/Base/profiles/trade6/logs/trade6/native_std
err.log
```

One way to analyze Verbose GC output from IBM Technology for Java VM is to use the Extensible Verbose GC Toolkit (EVTk).

### 9.4.2 Using Extensible Verbose GC toolkit to monitor garbage collection

In 9.3.1, “Verbose Garbage Collection” on page 308, we explained how to capture Verbose GC output, which is then manually analyzed to support heap analysis and tuning activities. The IBM Support Assistant (see Appendix C, “IBM Support Assistant” on page 421) provides a verbose GC data visualizer tool, the Extensible Verbose GC Toolkit (EVTk), that can assist you in performing such a task.

## Overview of EVTK

EVTK parses and plots verbose GC logs and -Xtgc output produced by both Classic JVM and IBM Technology for Java VM. It provides a graphical display of a wide range of verbose GC data values, and at the time of writing is compatible with optthruput, optavgpause, and gencon GC policies.

You can use EVTK to support GC tuning and also general GC analysis and troubleshooting. We present a scenario where EVTK is used to analyze verbose GC output from a WebSphere Application Server environment that is not performing as well as expected. After we identify the possible cause of the performance bottleneck from the EVTK analysis, we make changes and use EVTK to confirm that the problem was resolved.

The scenario we present here involved a WebSphere Application Server V6.1.0.7 Base server with the Trade 6 performance sample application installed. WebSphere Application Server was running under IBM Technology for Java VM.

### **Trade 6 application**

IBM Trade Performance Benchmark Sample for WebSphere Application Server (otherwise known as *Trade 6*) is the WebSphere end-to-end benchmark and performance sample application. The new Trade benchmark was redesigned and developed to cover WebSphere's significantly expanding programming model, which provides a real world workload driving WebSphere's implementation of Java 2 Enterprise Edition (J2EE) 1.4 and Web Services that includes key WebSphere performance components and features.

### **Test scenario**

To stress the application server, we generated a simulated workload for the Trade 6 application using Rational Performance Tester V6.0.0.1. We configured verbose GC output prior to starting WebSphere Application Server by specifying the following in the Generic JVM arguments field:

```
verbosegclog:<filename>
```

The Generic JVM arguments field is accessed through the WebSphere Administrative Console for the application server, as shown in Figure 9-17 on page 313:

1. Expand **Servers** → **Application servers**.
2. Click the application server name you want to configure.
3. Under the Server Infrastructure section, expand **Java and Process Management**.
4. Click **Process Definition**.
5. Under the Additional Properties section, click **Java Virtual Machine**.
6. Enter the verbosegclog:<filename> value for the Generic JVM arguments field to specify the name of the verbose GC output file.
7. Click **OK**.
8. Save your changes to the configuration.
9. Restart WebSphere Application Server so that the change take effect.

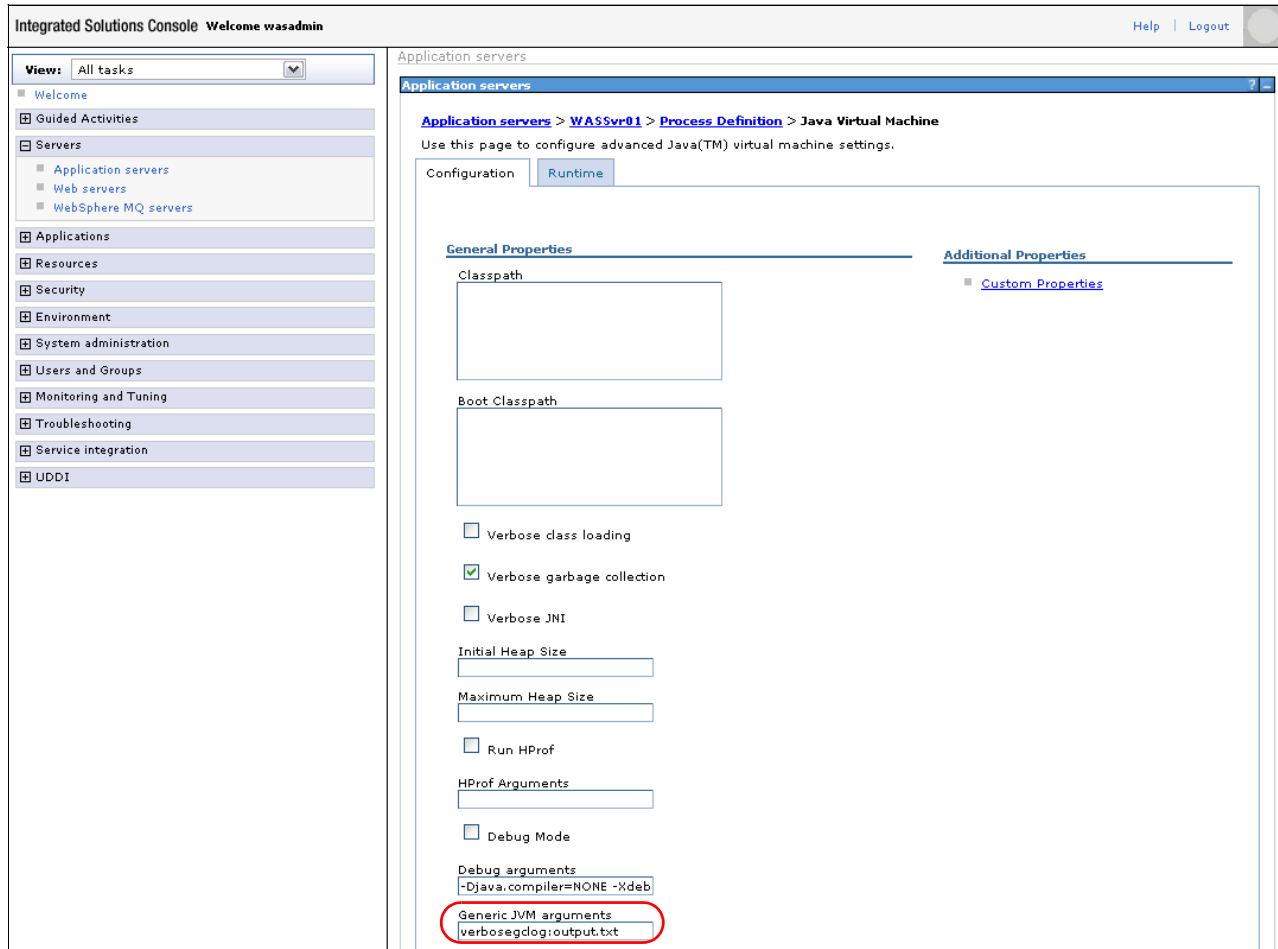

Figure 9-17

We used the default optthruput GC policy and initially ran the scenario with artificially small heap size settings so that the garbage collector would have to work very hard to prevent the heap from running out of space completely:

- ▶ Minimum (initial) heap size: 35 MB
- ▶ Maximum heap size: 60 MB

See 9.2.4, “Setting heap size for WebSphere Application Server” on page 306 for details about how to set the initial and maximum heap sizes used by the WebSphere Application Server JVM.

The resource constraints in this scenario are clearly highly exaggerated for the purposes of demonstrating the usage of EVTK for analyzing verbose GC data. Correspondingly, the results are not typical but show that for a highly-loaded and constrained application, GC pauses can have a measurable impact on application throughput and response time, as you might expect. EVTK allows us to determine that on this occasion the cause of poor performance is related to increased garbage collection due to insufficient resources.

The server was placed under load by Rational Performance Tester for ten minutes and the verbose GC log collected for analysis. Because garbage collection cycles occurred prior to test start, they were not due to the test workload. Data for these collections was manually removed from the verbose GC output before analysis with EVTK, which was necessary so that the graphs produced by EVTK and Rational Performance Tester covered the same period and could therefore be compared like-for-like.

It is possible to change the period of verbose GC data displayed in EVTK, but you have to adjust both the start and end times that are displayed through EVTK to correlate to the start of the test (as opposed to the startup of the JVM) for the same reason. We felt it was more accurate to edit the verbose GC log file manually because we could refer to the time stamp in each GC cycle entry and tell for certain whether it occurred during the test period.

### Viewing verbose GC data in EVTK

To view the verbose GC data in EVTK, we used the following procedure:

1. Copy the verbose GC output log file from i5/OS to a PC with the IBM Support Assistant installed.
2. Start IBM Support Assistant.
3. Start EVTK from the IBM Support Assistant by selecting **IBM Support Assistant** → **Extensible Verbose Toolkit**, as shown in Figure 9-18.

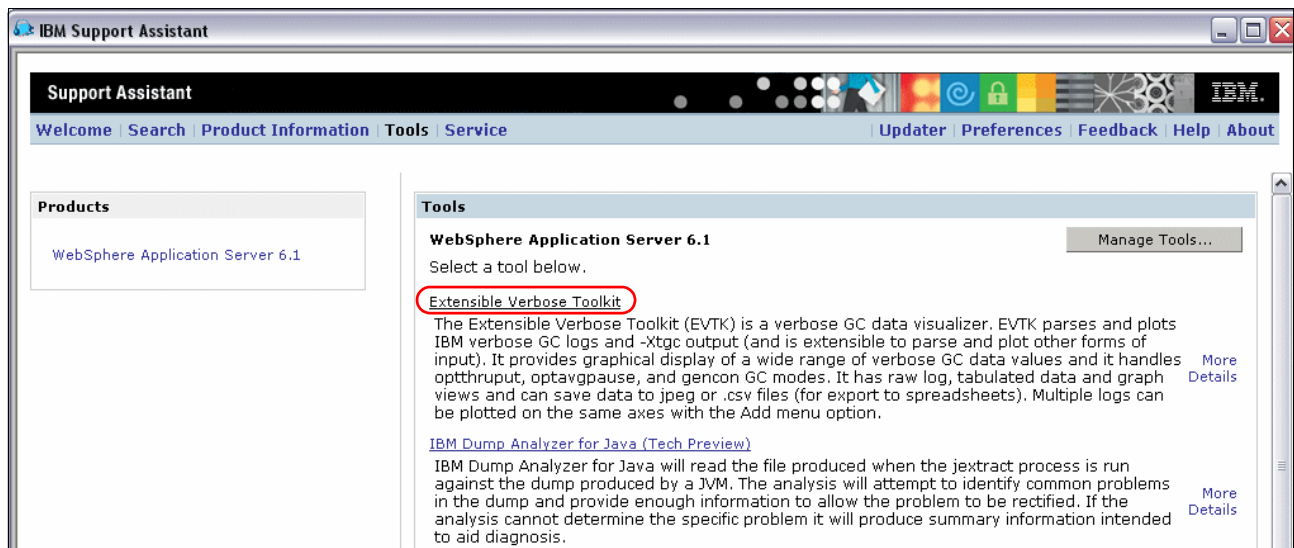

Figure 9-18 Launching EVTK from IBM Support Assistant

4. Select **File** → **Open File**.
5. Locate the verbose GC log file to be analyzed, and click **Open**. EVTK processes the verbose GC log and displays a default chart from the data, as shown in Figure 9-19 on page 315.

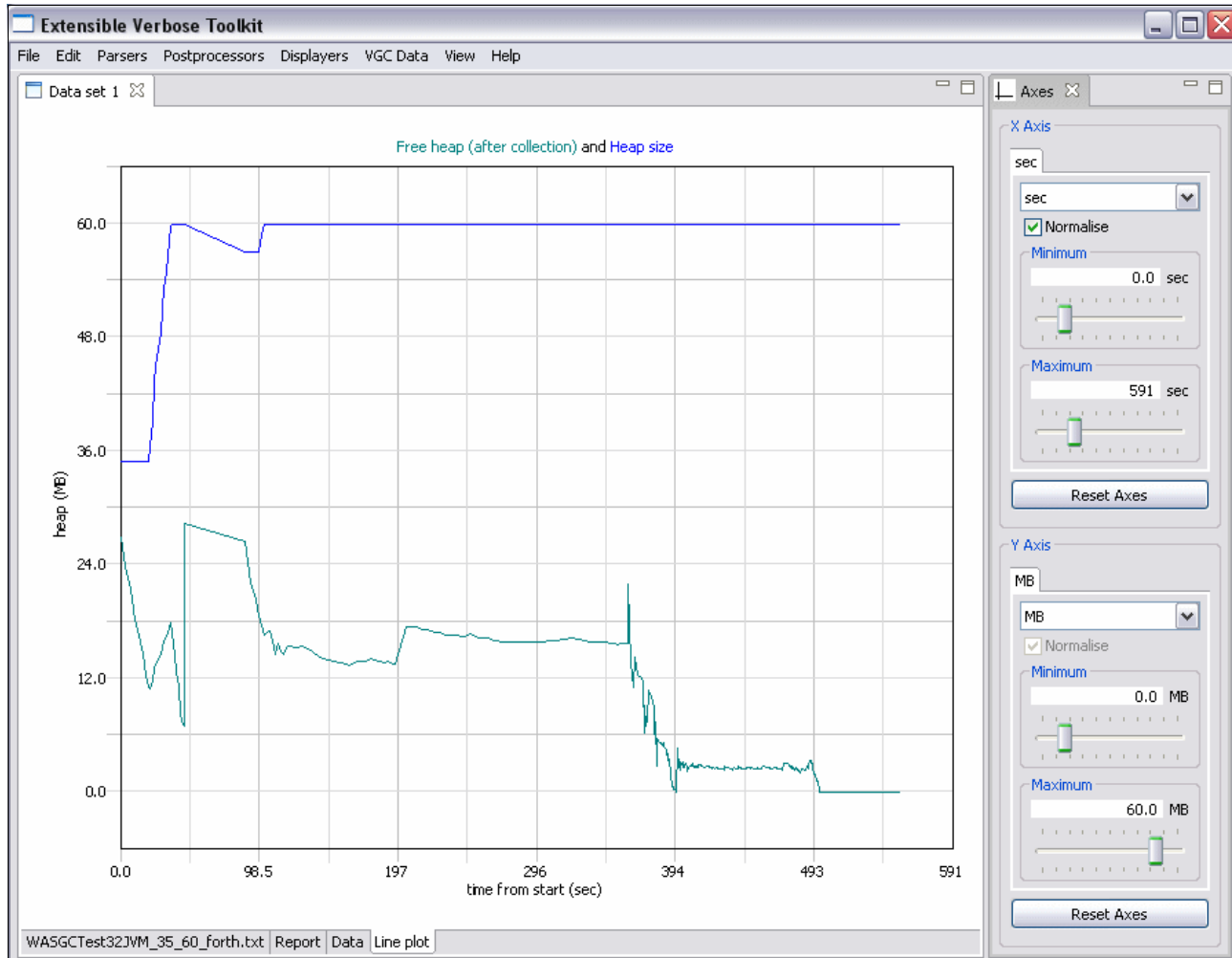

Figure 9-19 The default view displayed in EVTK after you open a verbose GC log file for analysis

The default graph did not meet our requirements. The data you want to visualize changes during the troubleshooting process, but fortunately displaying new graphs in EVTK is easy. You simply add or remove the data you want to plot through the VGC Data menu.

6. We wanted to look at how frequent and how long GC pauses were during the test period. To do this starting from the default graph shown in Figure 9-19:
  - a. Select **VGC Data**, and **Heap size** from the menu, as shown in Figure 9-20 on page 316. EVTK dynamically updates the graph to reflect the selections in the VGC Data menu.
  - b. Select **VGC Data**, and clear **Free heap (after collection)**, which gives a blank chart onto which you can plot the required data in the next step.
  - c. Select **VGC Data**, and check **Pause times (not including exclusive access)** to display GC pause data on the graph.

The results show in the chart in Figure 9-20 on page 316 and Figure 9-21 on page 317.

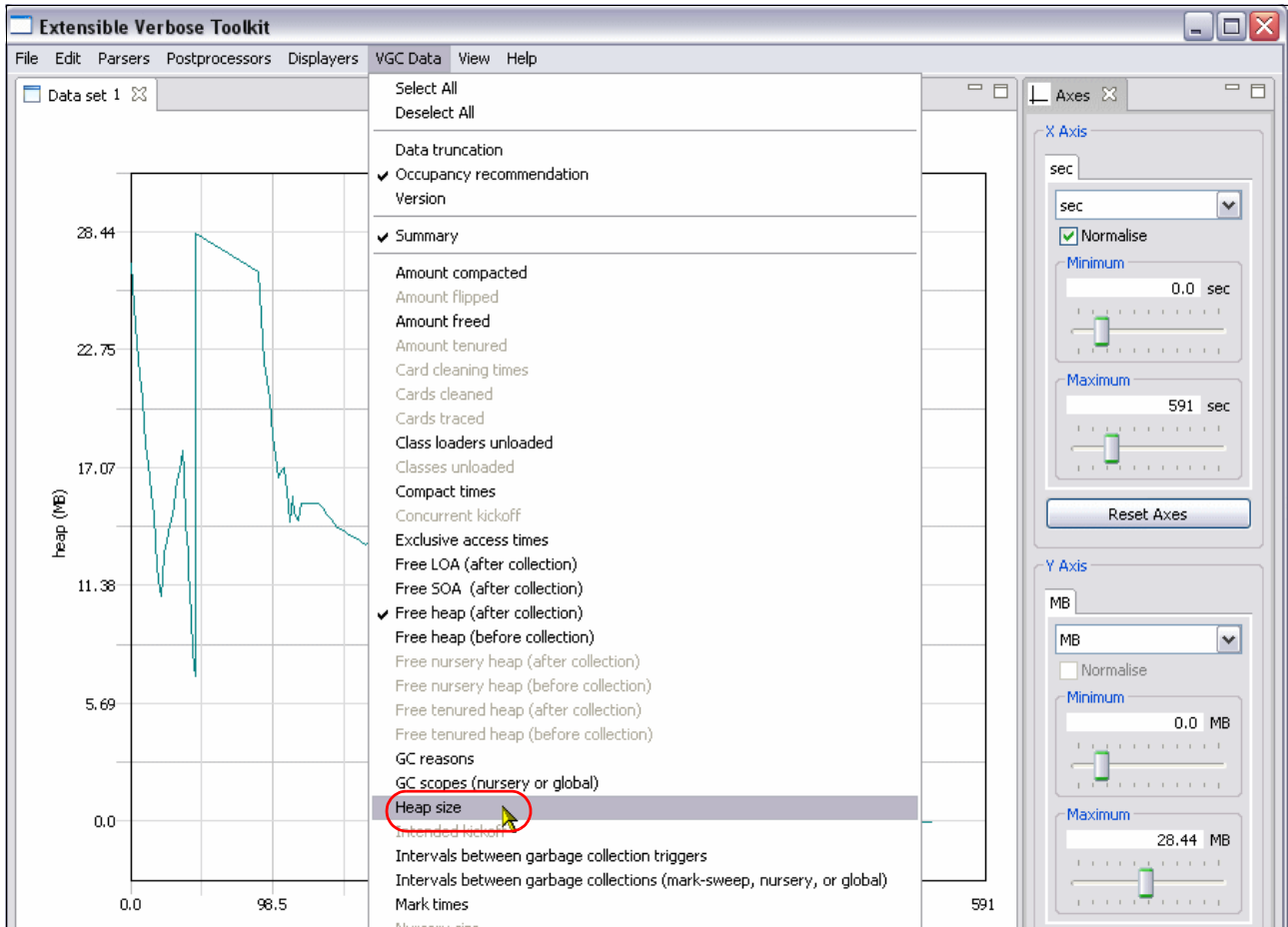

Figure 9-20 Deselect the Heap size data to give a better scale for the free heap space data

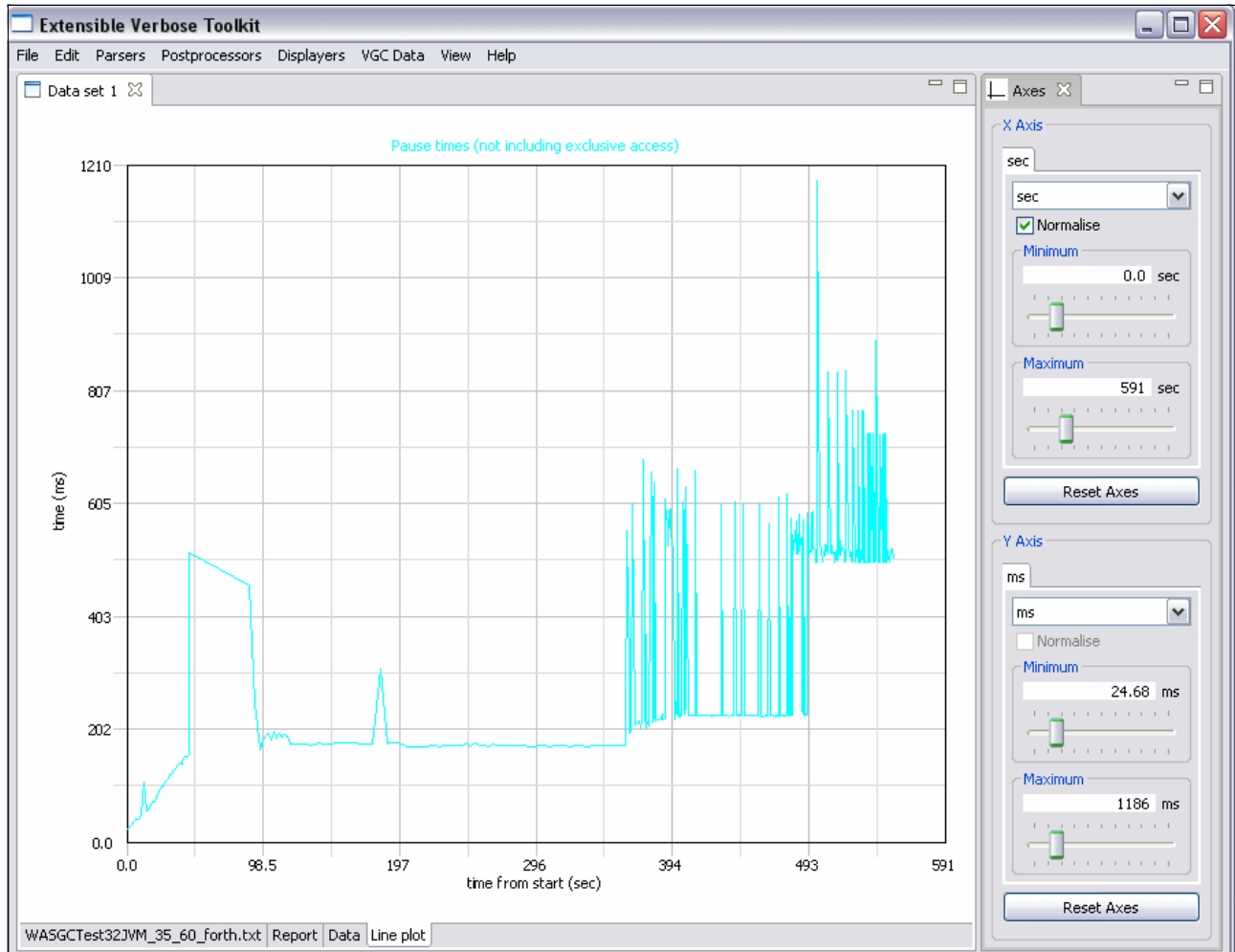

Figure 9-21 Plotting GC Pause times

### Test results

The effect of insufficient space in the heap on application throughput, application response times, and GC pause times is clear from the Rational Performance Tester charts that are shown in Figure 9-22 on page 318, Figure 9-23 on page 319, and Figure 9-24 on page 320.

Figure 9-22 shows that average response times increase as the workload on the WebSphere Application Server increases.

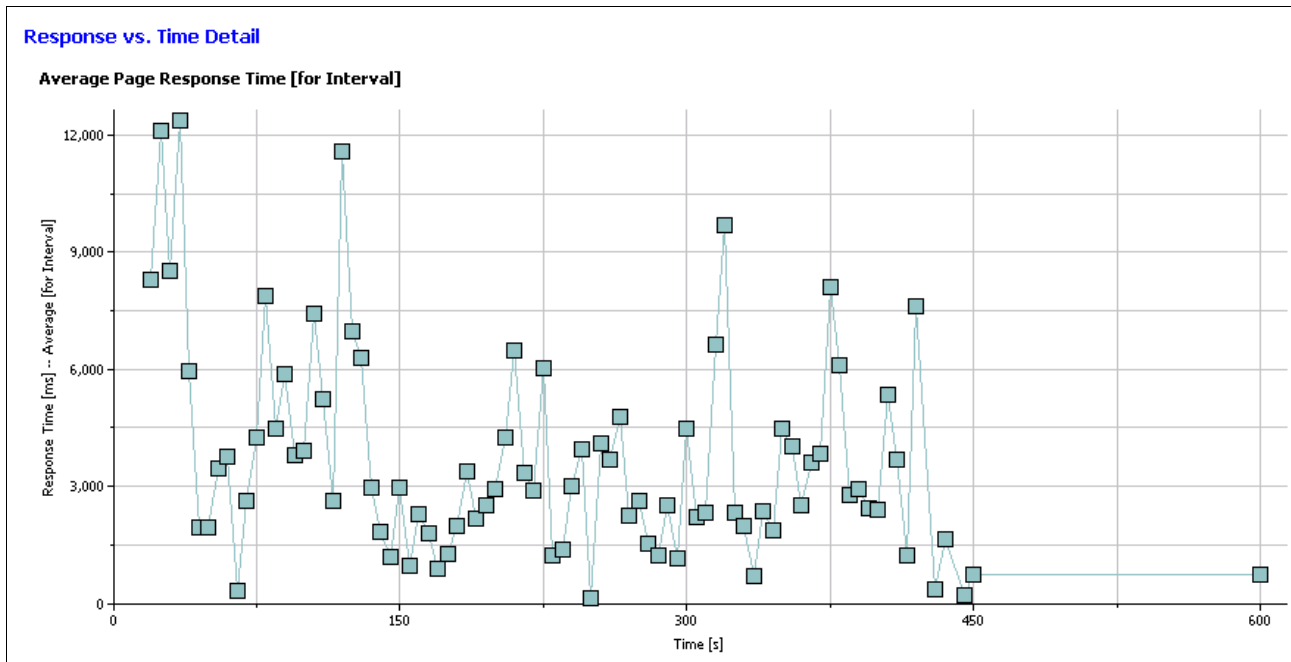

Figure 9-22 Response times increase as the workload increases

**Note:** The period of apparent response time decreases from approximately 400 seconds after test start onward, is misleading. The server at this time was occupied by the GC workload that tried to free up heap for new allocations. The response time in fact increased, but this was not detected by Rational Performance Tester.

Figure 9-23 on page 319 shows that the throughput of the Trade 6 application drops as the workload on the WebSphere Application Server increases. It reaches a point of zero throughput when the garbage collector is running very frequently to ensure that the heap does not completely run out of free space.

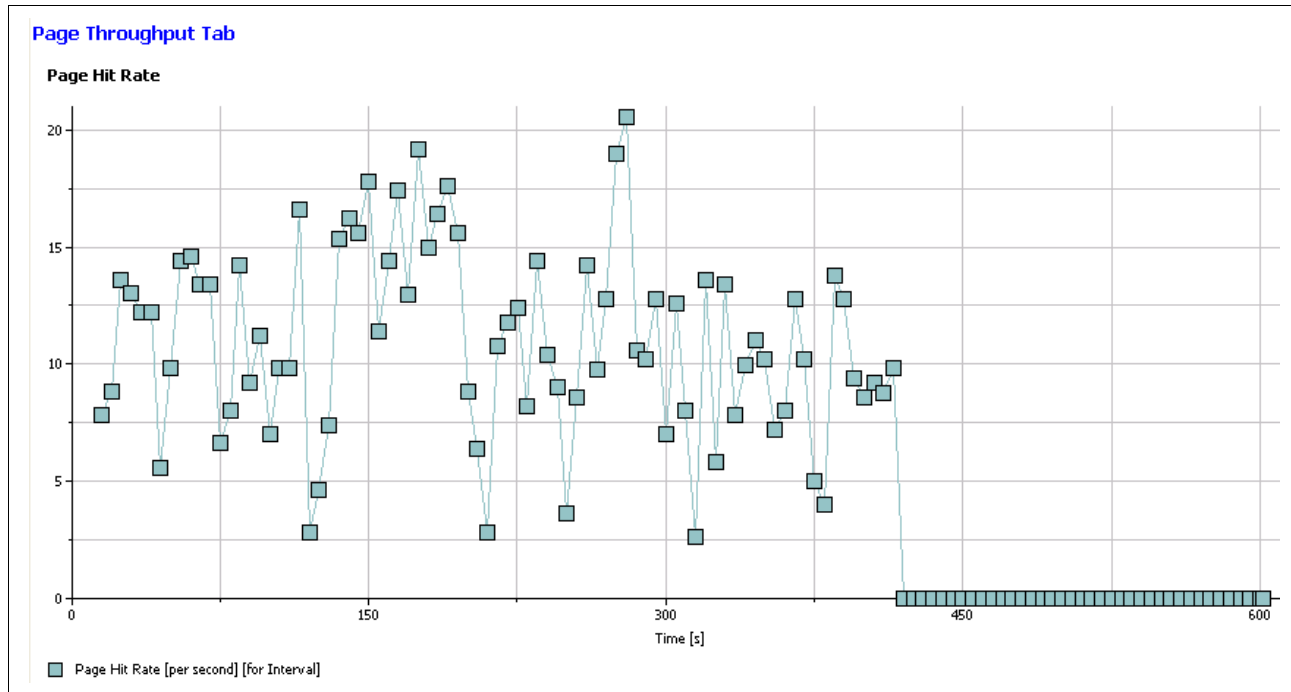

Figure 9-23 Throughput drops as response time (and GC pause times) increases

In Figure 9-21 on page 317, we observed that as the workload increases, garbage collections occur more frequently, and take longer. This is because of the very low maximum heap size. As the workload increases, the garbage collector has to frequently compact the heap to prevent the heap running out of free space completely.

### Further analyzing verbose GC data with EVTK

EVTK provides several ways of displaying verbose GC data, for example, data can be exported in CSV format or displayed as a graph. You can chart a wide variety of GC data, featuring just one value plotted against elapsed time (such as free heap space) or combining multiple values on one chart. Typically, this feature is used to easily see the relationship between multiple data values, such as free heap space and GC pause times. It is also possible to overlay data from multiple verbose GC logs on the same chart for comparative analysis between JVMs that are running with different GC settings.

In our case, we initially created a chart of the GC pause times in EVTK from the verbose GC data, using the steps in “Viewing verbose GC data in EVTK” on page 314. This clearly showed that GC pauses were occurring more frequently and getting longer as the workload increased, which leads us to suspect that the heap is running out of space under load.

You can use EVTK to easily verify your suspicion that the heap is running out of space by re-plotting the chart to show the free heap space remaining against time:

1. Select **VGC Data**, and clear **Pause times**, to give a blank chart.
2. Select **VGC Data**, and check **Free heap (after collection)**. Figure 9-24 on page 320 contains a chart with the results.

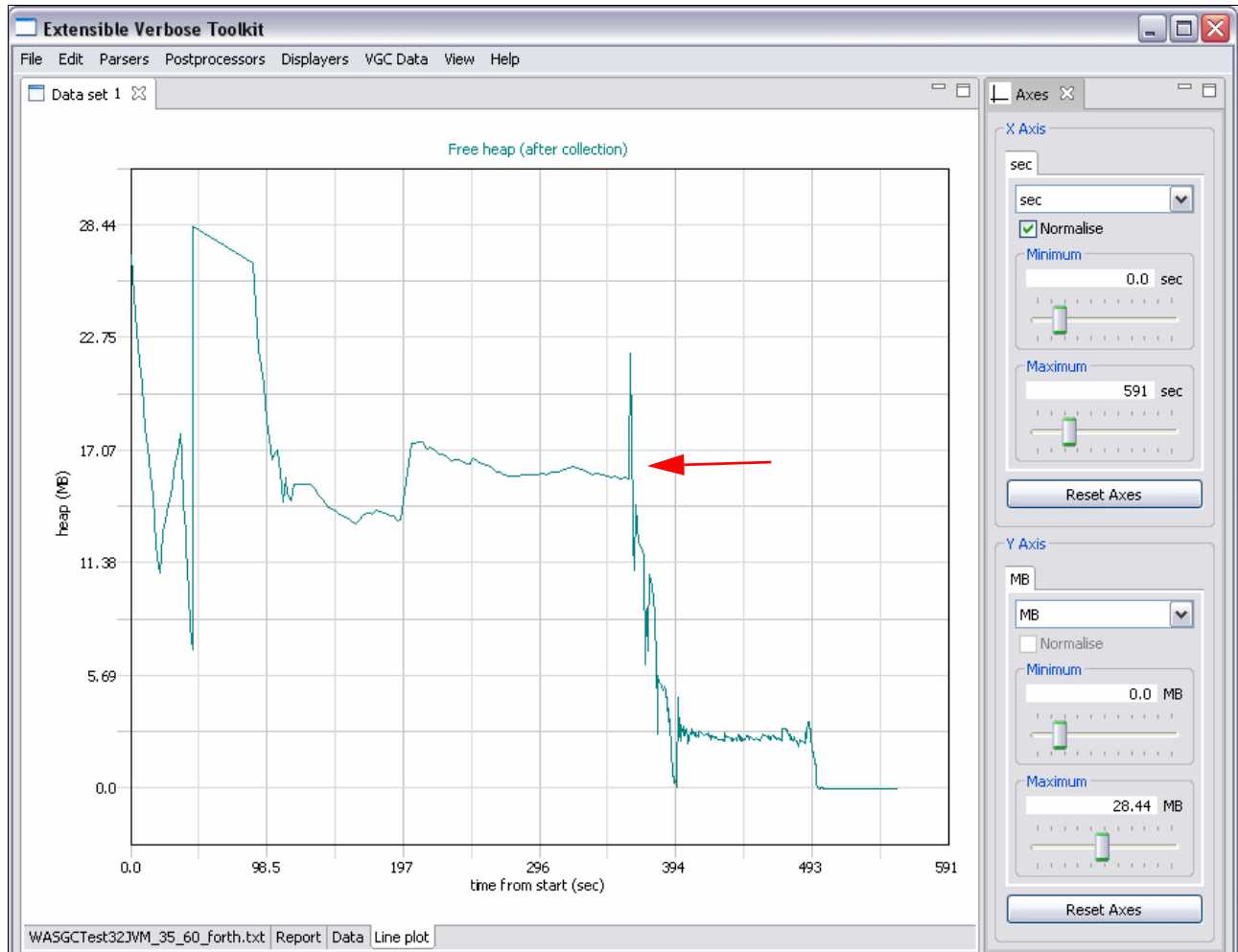

Figure 9-24 Plotting free heap size clearly shows that the heap is running out of space as workload increases

In Figure 9-24, you can see that at the half-way point in the test, the available free heap space suddenly and sharply decreases to very low levels, and the JVM eventually runs out of heap space, as indicated by the arrow in Figure 9-24.

We therefore adjust the heap settings as follows:

- ▶ Minimum (initial) heap size: 50 MB
- ▶ Maximum heap size: 256 MB

Restart WebSphere Application Server so that the new heap size settings take effect.

### **Results with new heap size settings**

Running the scenario again, Figure 9-25 on page 321 and Figure 9-26 on page 321 show the positive effect on application response time and throughput.

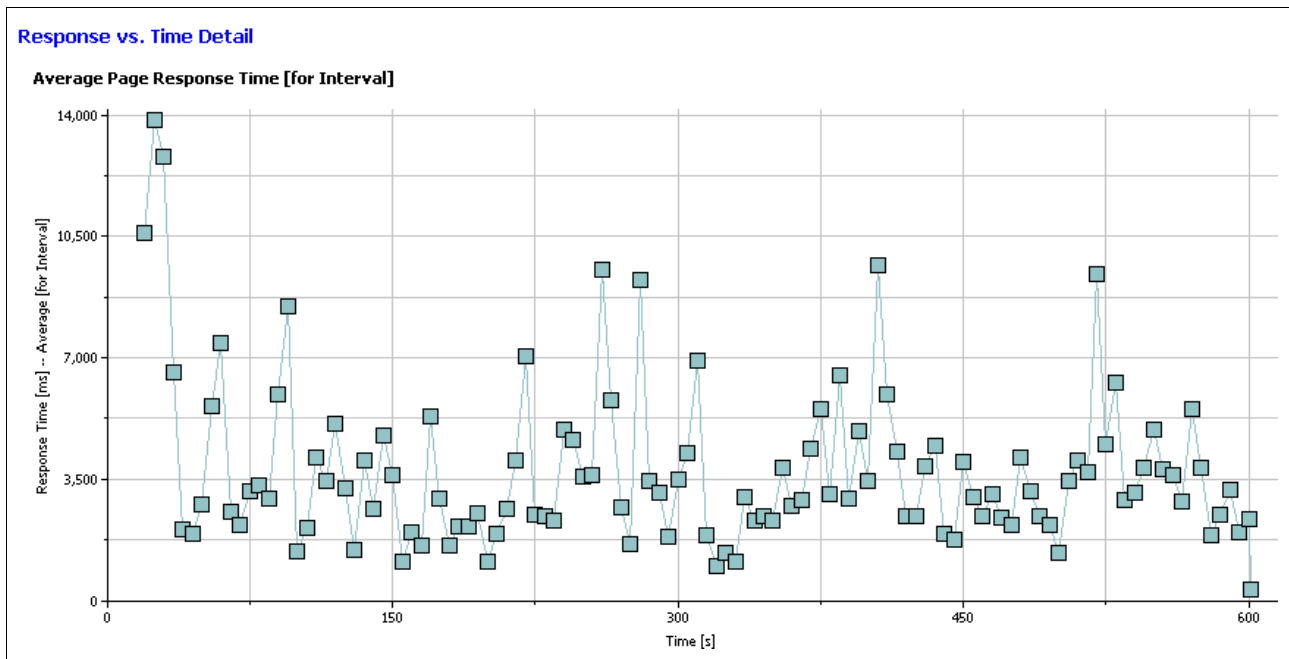

Figure 9-25 Average response time decreases after adjusting heap settings to more appropriate values

The application throughput also increases with the new heap settings, as shown in Figure 9-26.

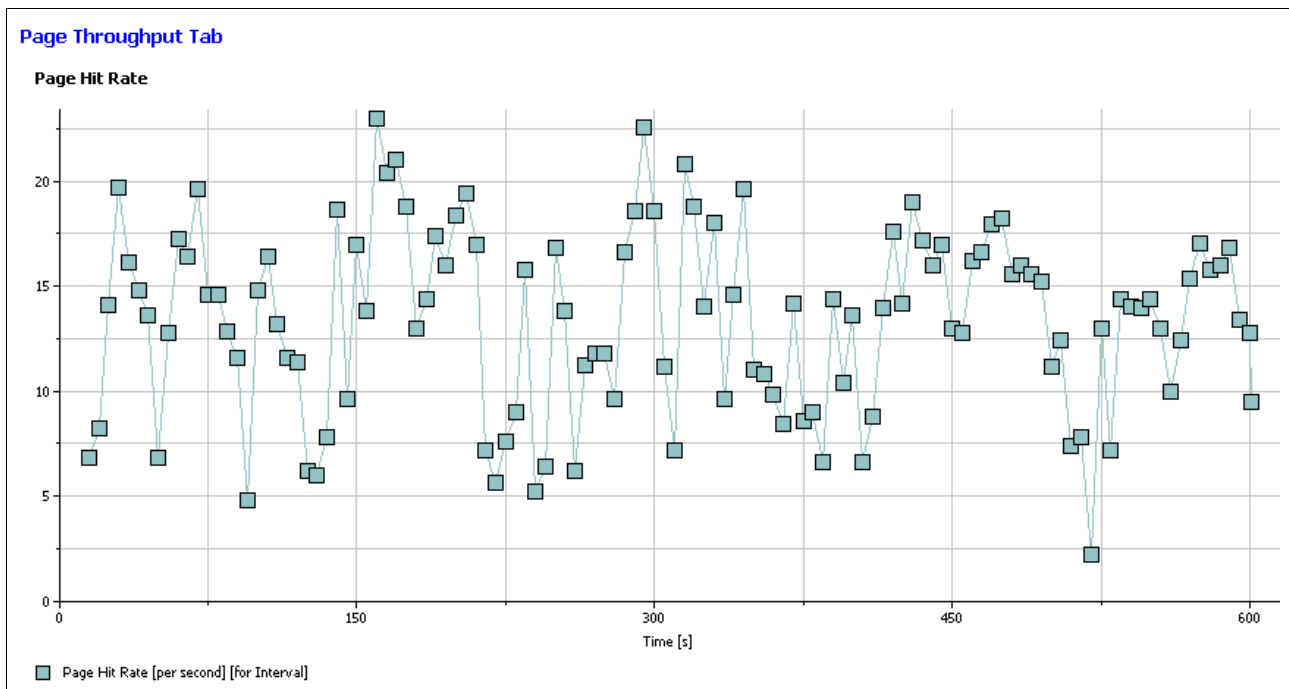

Figure 9-26 Application throughput increases after adjusting heap settings to more appropriate values

### Confirming improved GC performance with EVTK

We collected verbose GC output from the second run of the application to compare to the previous analysis and to confirm that GC is operating more efficiently.

EVTK allows you to plot data from multiple verbose GC logs simultaneously on the same chart, which is very useful for comparison purposes. In our scenario, we overlaid the free heap data from the application run with new heap settings, over the data from the problematic run:

1. Copy the new verbose GC log file from i5/OS to the PC that is running EVTK.
2. Open the original verbose GC log file, if it is not currently open, and plot the “Free heap (after collection)” data only:
  - a. Select **File** → **Open File**.
  - b. Select the original verbose GC log file, and click **Open**. The default graph of the original data displays in EVTK showing Heap size and Free heap (after collection).
  - c. Select **VGC Data**, and clear **Heap size**.
3. Add the data from the latest test with new heap settings, to the graph:
  - a. Select **File** → **Add File**.
  - b. Select the new verbose GC log file, and click **Open**.

The new data is then displayed as the blue plot line in the chart shown in Figure 9-27.

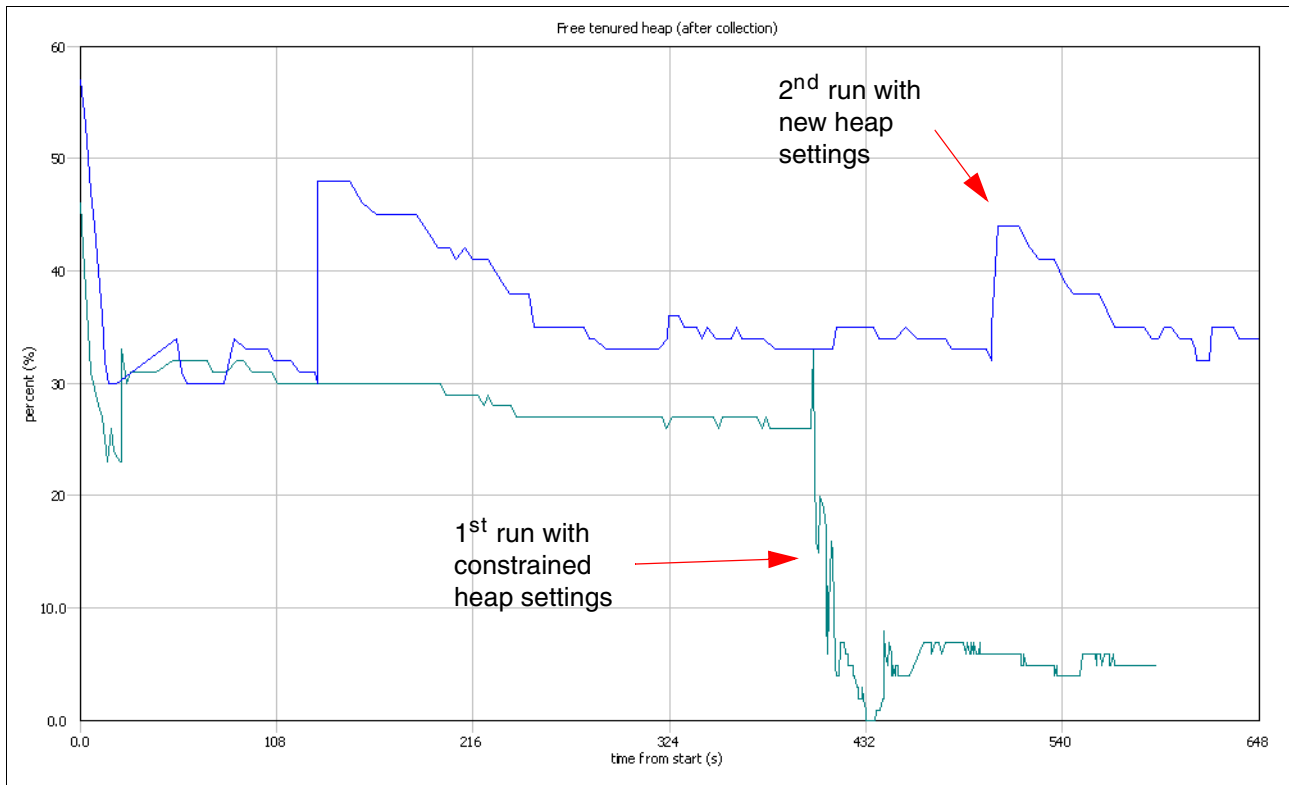

Figure 9-27 More free heap space is available after adjusting heap settings to more appropriate values

You can see from the new data plot in Figure 9-27 that the heap no longer rapidly runs out of space as the application workload increases.

In this section, we showed how to use EVTK to analyze garbage collection behavior in the WebSphere Application Server JVM process.

### 9.4.3 Javacore/Java dump

During the run time of a Java process, occasionally the JVM may not respond predictably and may seem to stop responding for a long time or until a JVM shutdown occurs. It is often not easy to determine the root cause of such problems.

By triggering the creation of a javacore file when a Java process does not respond, it is possible to collect diagnostic information that is related to the JVM and a Java application that is captured at a particular point during execution, for example, the information can be about the operating system, the application environment, threads, native stack, locks, and memory. The exact contents are dependent on the platform on which the application is running.

On some platforms, a Javacore is known as a *Java dump*. The code that creates a Javacore is part of the JVM. You can control it by using environment variables and runtime switches. By default, a Javacore occurs when the JVM terminates unexpectedly. A Javacore can also be triggered by sending specific signals to the JVM, through the keyboard.

To force the creation of a Javacore dump, if you suspect the JVM has hung:

1. Run the Work With Active Jobs (WRKACTJOB) i5/OS command. Page down until you find the job that is associated with your instance of WebSphere Application Server. In our example, it is called TRADE6 and is located under the QWAS61 subsystem.
2. Use option **5** to work with the job.
3. Use option **10** to display the job log.
4. Press F10 to display detailed messages. You see a display similar to Figure 9-28.

```
Display All Messages
System: RCHAS60
Job . . . : TRADE6      User . . . : QEJBSVR      Number . . . : 110842

>> CALL PGM(QWAS61A/QWASSTRSVR) PARM('-profilePath' '/QIBM/UserData/WebSphere
/AppServer/V61/Base/profiles/Trade6' '-server' 'trade6')
ACGDTA for 110842/QEJBSVR/TRADE6 not journaled; reason 1.
Java Virtual Machine is IBM Technology for Java. PID(343)
Server starting with user profile QEJBSVR and JDK 1.5.0.
```

Figure 9-28 Display messages in TRADE6 job log

5. Take note of the process ID number for our job, which in this case is 343.
6. Exit this display, and enter the QSH command entry mode using the STRQSH i5/OS command.
7. Enter the command **kill -quit 343**. You must substitute the process ID number of your process. 343 was the process ID of our job

You will see messages that tell you that a dump was created and that tell you the location of the dump, as shown in Figure 9-29 on page 324.

```
JVMDUMP006I Processing Dump Event "user", detail "" - Please Wait.
JVMDUMP007I JVM Requesting Java Dump using
'/QIBM/UserData/WebSphere/AppServer/V61/Base/profiles/trade51/javacore.2
0060810.134239.343.txt'
JVMDUMP010I Java Dump written to
/QIBM/UserData/WebSphere/AppServer/V61/Base/profiles/trade51/javacore.2
060810.134239.343.txt
JVMDUMP013I Processed Dump Event "user", detail "".
```

Figure 9-29 Display messages showing Javacore being created

## 9.4.4 ThreadAnalyzer

The ThreadAnalyzer tool, which is available through the IBM Support Assistant, can detect whether any deadlocks are occurring in a Java application. ThreadAnalyzer is designed primarily to analyze Javacore files (also known as Java or thread dumps) from WebSphere Application Server.

**Tip:** Because the Javacore is created at the JVM level, you can also use it to analyze stand-alone applications that are not running within WebSphere Application Server.

You can analyze thread usage at several different levels, starting with a high-level graphical view and drilling down to a detailed tally of individual threads. If any deadlocks exist in the thread dump, ThreadAnalyzer detects and reports them.

### Generating the input Javacore for ThreadAnalyzer

A Javacore file is required as input to ThreadAnalyzer, which you can generate non-destructively by giving the following command in a Qshell session (see 9.4.3, “Javacore/Java dump” on page 323):

```
kill -QUIT <process ID>
```

**Important:** The JVM continues running after you issue the `kill` command. However if you are troubleshooting an unresponsive WebSphere Application Server process, you can terminate the JVM job manually through WRKACTJOB after collecting a Javacore in order to restart the application server.

In our case, the process ID of the WebSphere Application Server JVM is 10856, as shown in the job log in Figure 9-30 on page 325. We run the following command in a Qshell session to generate the Javacore that is required by ThreadAnalyzer:

```
kill -QUIT 10856
```

Refresh the job log by pressing F5. You can see messages posted in the job log as the Javacore is created, also shown in Figure 9-30 on page 325.

```

                                Display All Messages
                                System:   RCHAS60
Job . . . :   AVN01           User . . . :   QEJBSVR           Number . . . :   695698

Job 695698/QEJBSVR/AVN01 started on 06/04/07 at 18:35:45 in subsystem
      QWAS61 in QWAS61. Job entered system on 06/04/07 at 18:35:45.
      Job 695698/QEJBSVR/AVN01 submitted.
>> CALL PGM(QWAS61A/QWASSTRSVR) PARM('-profilePath' '/QIBM/UserData/WebSphere
/AppServer/V61/Base/profiles/avn01' '-server' 'avn01')
ACGDTA for 695698/QEJBSVR/AVN01 not journaled; reason 1.
Java Virtual Machine is IBM Technology for Java. PID(10856)
Server starting with user profile QEJBSVR and JDK 1.5.0.
WebSphere application server avn01 ready.
JVMDUMP006I Processing Dump Event "user", detail "" - Please Wait.
JVMDUMP007I JVM Requesting Java Dump using
      '/QIBM/UserData/WebSphere/AppServer/V61/Base/profiles/avn01/javacore.200
70606.160646.10856.txt'
JVMDUMP010I Java Dump written to
      /QIBM/UserData/WebSphere/AppServer/V61/Base/profiles/avn01/javacore.2007
0606.160646.10856.txt
JVMDUMP013I Processed Dump Event "user", detail "".

                                                                Bottom

Press Enter to continue.

F3=Exit   F5=Refresh   F10=Display detailed messages   F12=Cancel
F16=Job menu   F24=More keys

```

Figure 9-30 The process ID of a WebSphere Application Server JVM is found in the job log

The name and location of the Javadump file is given in the job log so that you can find it easily. In our case, the Javadump file is as follows:

```

/QIBM/UserData/WebSphere/AppServer/V61/Base/profiles/avn01/javacore.200
70606.160646.10856.txt

```

### Analyzing the Javadump with ThreadAnalyzer

The next step is to launch ThreadAnalyzer from IBM Support Assistant and analyze it, for example to determine if there are any deadlocks:

1. Ensure that IBM Support Assistant is running. Refer to Appendix C, “IBM Support Assistant” on page 421 for more information about installing and configuring IBM Support Assistant.
2. On the IBM Support Assistant Welcome Page, Click **Tools**.
3. Under Products, click **WebSphere Application Server 6.1**.
4. Click **ThreadAnalyzer**. A separate window opens with a message Launching ThreadAnalyzer Tool....
5. After ThreadAnalyzer starts, you have to import the Javadump file for analysis. Either copy the Javadump file from the i5/OS to the PC where you are running ThreadAnalyzer, or map a drive letter to the i5/OS file system. We copied the Javadump file locally.

- From the Thread Dumps menu, select **Open Existing File**. Select the Javadump file that is generated for this JVM, as shown in Figure 9-31.

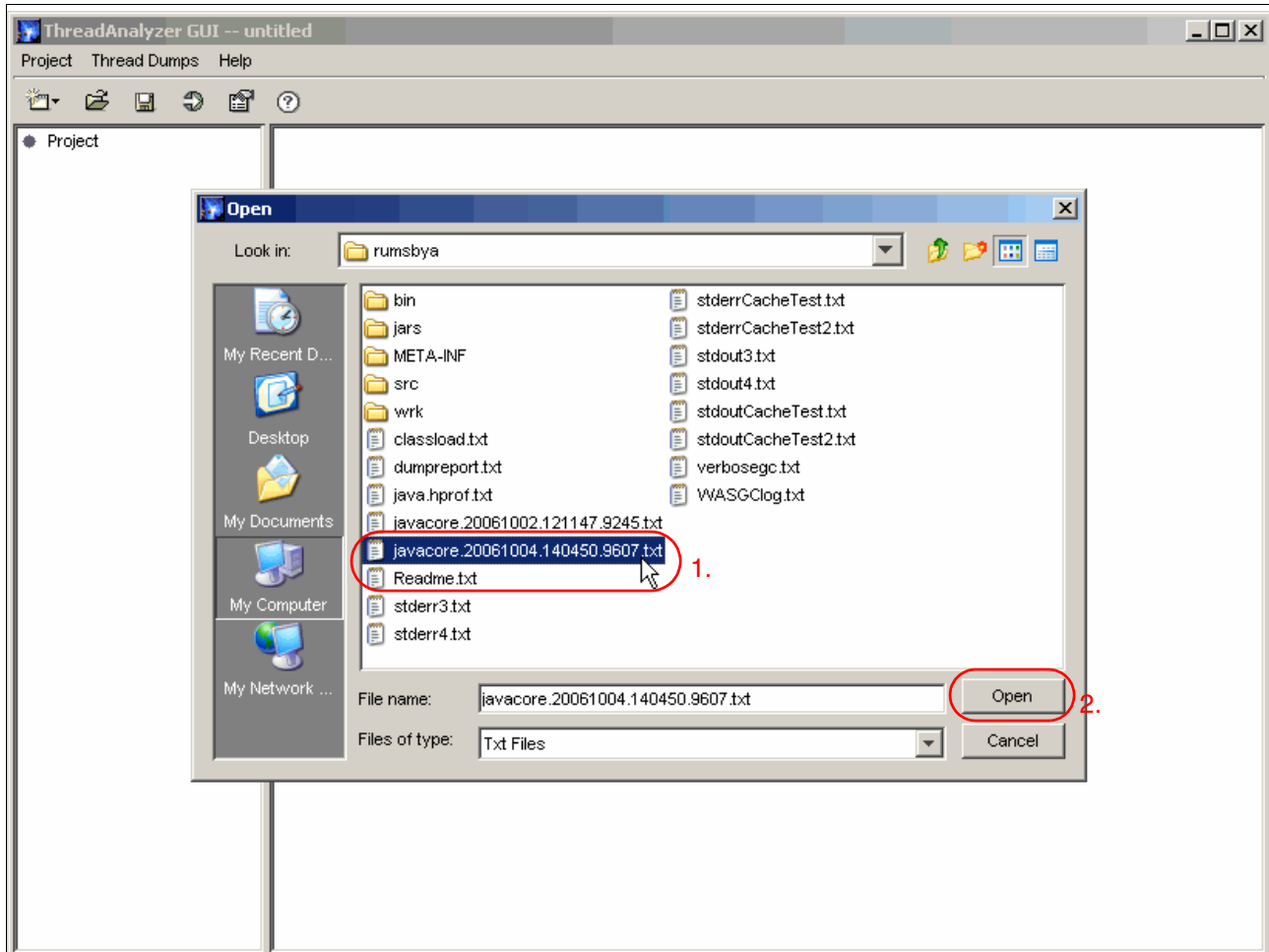

Figure 9-31 Select the Javadump to process with ThreadAnalyzer

- Click **Open** to import the Javadump into ThreadAnalyzer. ThreadAnalyzer processes the Javadump.
- Click **OK** on the Open Existing File(s) dialog when ThreadAnalyzer has completed processing.
- Expand the root entry for the Javadump that was just processed (in this case there is only one entry), and click **Summary**.

Any deadlocks that were detected are indicated by a “bang” icon and in the summary, as highlighted in Figure 9-32 on page 327.

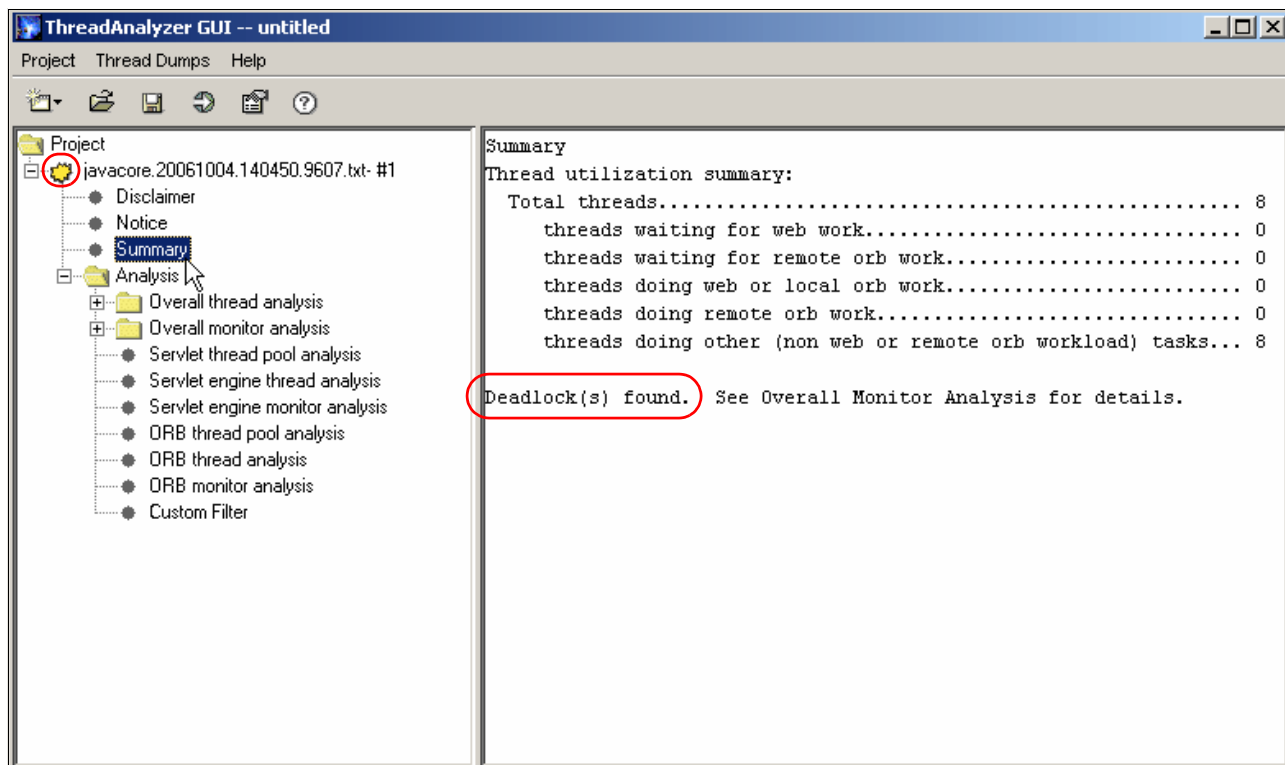

Figure 9-32 ThreadAnalyzer summary shows any deadlocks that were detected

10. To get more information about the threads, you can expand the **Analysis** → **Overall thread analysis** sub-folder in the left Navigation area.

In this section, we introduced you to ThreadAnalyzer, which is typically used to troubleshoot WebSphere Application Server JVM processes that have stopped responding. For a more detailed walk-through of a scenario where ThreadAnalyzer is used to analyze a deadlocked JVM, see Chapter 8.4 of the IBM Redbooks publication *IBM Technology for Java Virtual Machine in IBM i5/OS*, SG24-7353.

## 9.4.5 Heapdump

The JVM can optionally take a dump of the Java Heap. This file is a binary file that is only readable by parsing programs, such as Memory Dump Diagnostic for Java (MDD4J). The heap dump is generated by default when an *OutOfMemoryError* occurs in the JVM or it is initiated by the user.

You can generate a heap dump on your server using the wsadmin tool:

1. Start a QShell session with the STRQSH command.
2. Change the directory so that you are in the product bin directory. For our installation we used the command:

```
cd /QIBM/ProdData/WebSphere/AppServer/V61/Base/bin
```

3. Invoke the wsadmin script to connect to your running application server. For our WebSphere Application Server trade6 the command is:

```
wsadmin -profileName trade6
```

You should see a message similar to that shown in Figure 9-33 on page 328

```
WASX7209I: Connected to process "trade6" on node RCHAS60_trade6 using SOAP
connector; The type of process is: UnManagedProcess
WASX7029I: For help, enter: "$Help help"
wsadmin>
```

Figure 9-33 Connect to server using wsadmin

4. Enter the following two commands to generate the heap dump. In our example, trade6 is the name of our WebSphere Application Server:

```
set jvm [$AdminControl completeObjectName type=JVM,process=trade6,*]
$AdminControl invoke $jvm generateHeapDump
```

The command is successful if the location of the output file is displayed after the command completes such as shown in Figure 9-34

```
> $AdminControl invoke $jvm generateHeapDump

/QIBM/UserData/WebSphere/AppServer/V61/Base/profiles/trade6/./heapdump.20060810
.162349.343.phd
wsadmin>

===>
```

Figure 9-34 heapdump file created

After the heapdump file is created, you can analyze it using the Memory Dump Diagnostic tool for Java (MDD4J).

## 9.4.6 Memory Dump Diagnostic for Java (MDD4J)

The Memory Dump Diagnostic for Java tool analyzes heapdump files. You can use this tool to assist in the analysis of memory leaks. The MDD4J tool is available through the IBM Support Assistant, which we document in Appendix C, “IBM Support Assistant” on page 421.

Java memory leak diagnosis requires two steps:

1. Identify where the memory leak is:
  - Identify the objects, the unintentional references, the classes and objects that are holding those unintentional references, and the objects to which the unintentional references are pointing.
2. Identify why the leak is happening:
  - Identify the source code (program logic) that is responsible for not releasing those unintentional references at the appropriate point in the program.

The Memory Dump Diagnostic for Java tool aids in the process of determining where the memory leak is occurring in the application by identifying growing data structures of large sizes. However, the tool does not aid in identifying the faulty source code that is responsible for causing the memory leak. After the leaking data structure is identified, with the aid of this tool, you can use any debugger or use specific trace statements in logging to identify the faulty source code, and make the necessary changes to the application code to resolve the memory leak.

To analyze a heapdump file using MDD4J:

1. Start the IBM Support Assistant. Refer to Appendix C, “IBM Support Assistant” on page 421 for details.
2. Select **Tools** → **WebSphere Application Server 6.1** → **Memory Dump Diagnostic for Java**, as shown in Figure 9-35.

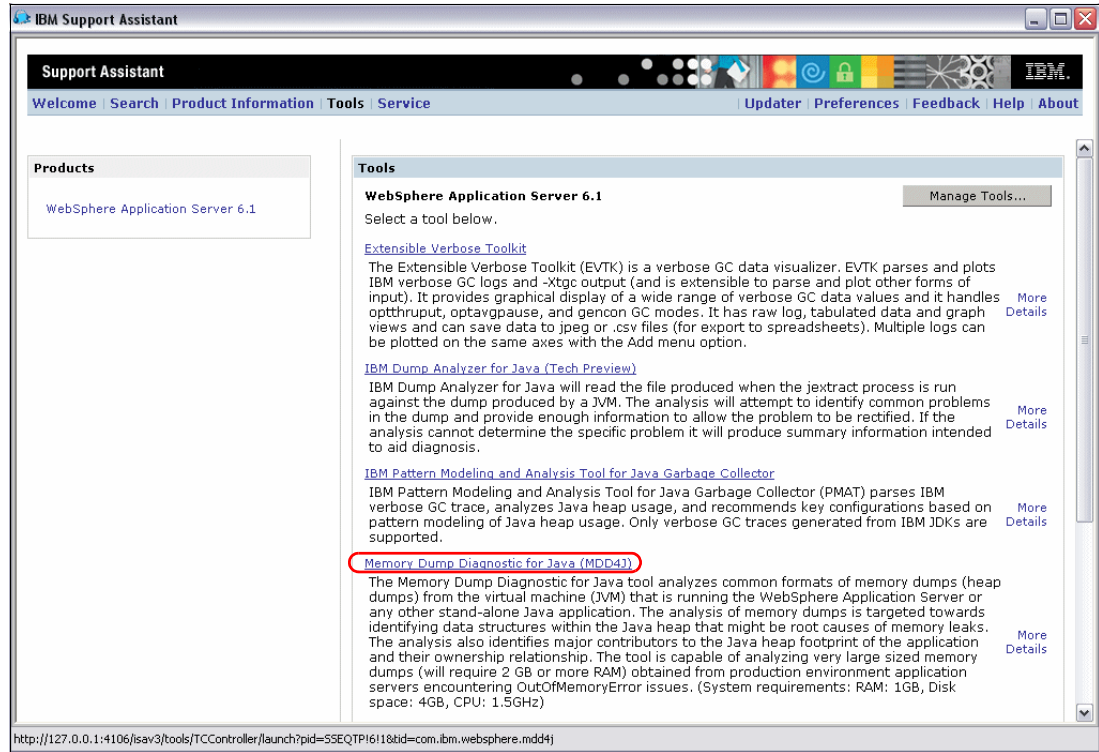

Figure 9-35 Select Memory Dump Diagnostic for Java (MDD4J)

**Tip:** If you select **More Details**, as shown in Figure 9-35, you have access to a large amount of help information about how to interpret the data in this tool.

3. Enter the location of the heapdump file that is to be processed in the Primary Memory Dump File URL field, and click the **Upload and Analyze** button. You are presented with a status window, such as the one shown in Figure 9-36 on page 330. This is a long running task.

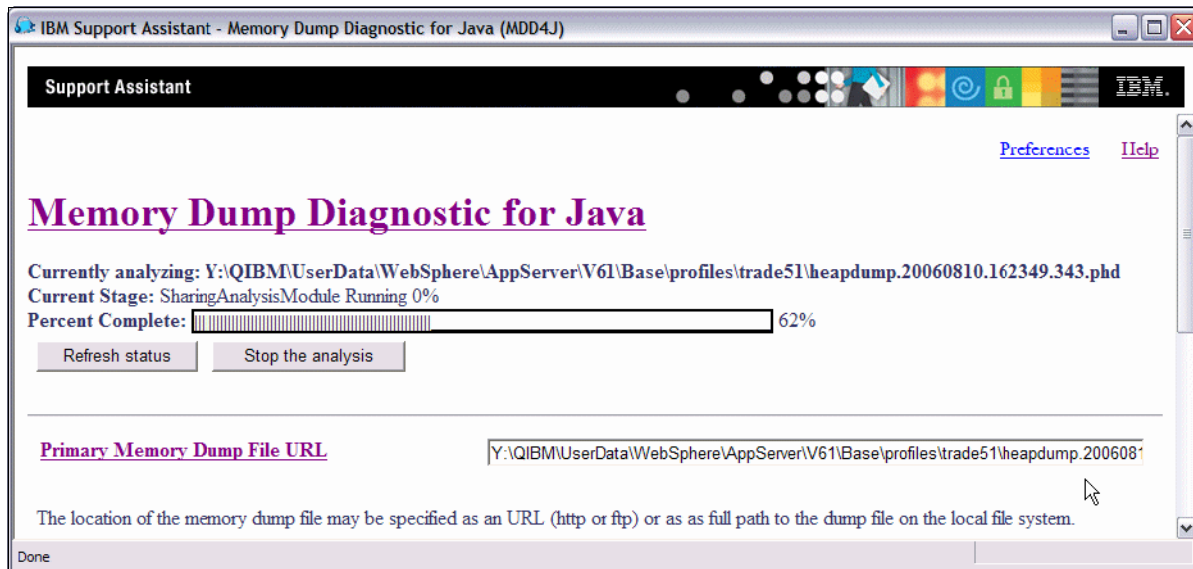

Figure 9-36 Memory Dump Diagnostic for Java analysis status

When the analysis completes, you are presented with the Summary of Analysis Results page, as shown in Figure 9-37.

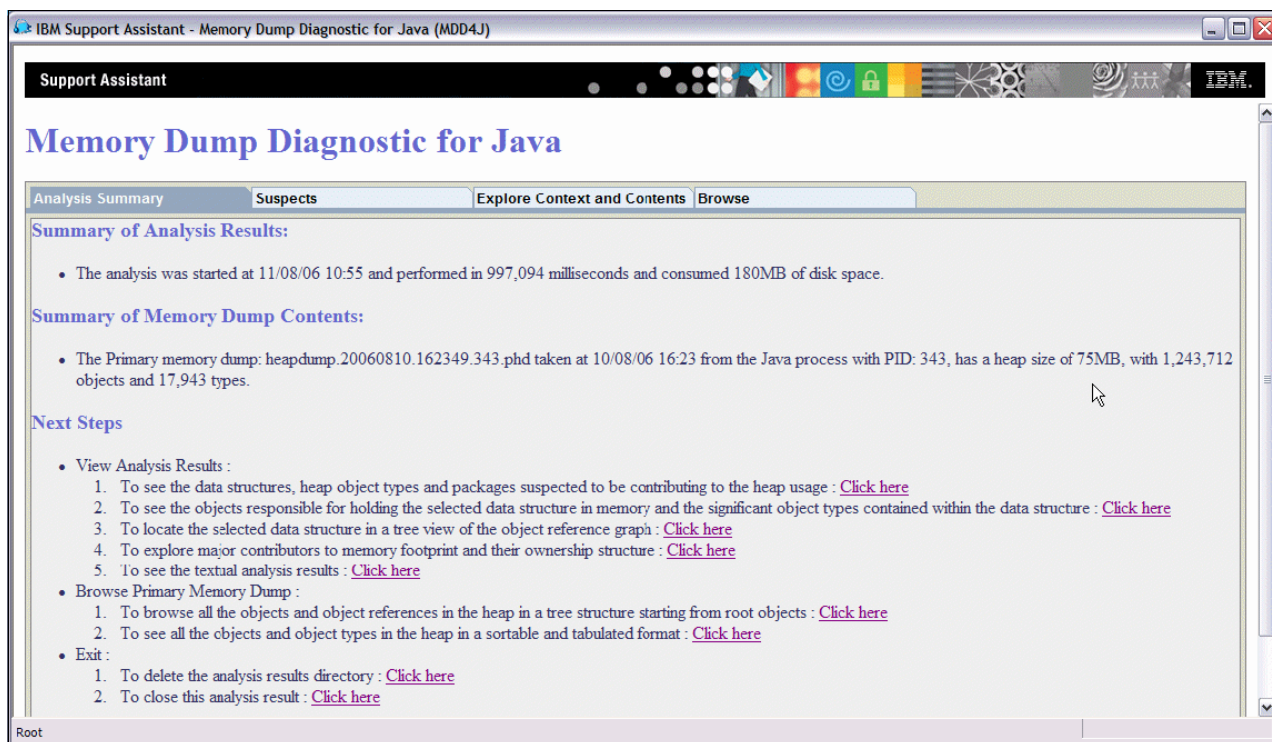

Figure 9-37 Summary of Analysis Results

The Analysis Results page has four tabs:

- ▶ **Analysis Summary:** Shows the summary of the analysis results and lists the next set of steps for viewing the analysis results.
- ▶ **Suspects:** Shows four types of suspects:
  - Data structures that contribute most to the growth

- Data structures that experience significant drops in reach size
- Types of objects with large number of instances
- Java packages with a large number of object instances
- ▶ Explore Context and Contents: Shows a graph of the ownership context of major contributors to the footprint of the Java heap in the primary memory dump and the contents of selected nodes in the graph.
- ▶ Browse: Shows all of the contents of the primary memory dump in a tree view, which based on a depth-first traversal of the object reference graph.

For more information about MDD4J, read chapter 8 in *IBM Technology for Java Virtual Machine in IBM i5/OS*, SG24-7353.

## 9.5 Analyzing a WebSphere Application Server JVM using PEX

If you confirmed that the JVM is consuming excessive CPU resources, you must determine what the JVM is doing to consume the CPU. One way to do this is to execute a Performance Explorer (PEX) \*PROFILE against the WebSphere Application Server job. It collects information about the code that a processor is executing at a defined time interval. It not only captures the currently running instruction, it can also gather details on up to 16 levels of thread instructions in the stack that is executing.

The \*PROFILE collection gathers the exact method names that are consuming the CPU within the WebSphere Application Server job. To view this breakdown by methods, you need to use Performance Trace Data Visualizer (PTDV). You can download PTDV from the IBM alphaWorks® Web site at:

<http://www.alphaworks.ibm.com/tech/ptdv>

**Restriction:** To create the PEX reports, you need to have licensed program product Performance Tools (5722-PT1) installed. To use PTDV, you do not need this product.

Create a PEX trace that shows CPU utilization for garbage collection:

1. Start a 5250 session.
2. On the i5/OS command line, create a PEX \*PROFILE definition for the WebSphere Application Server profile (Trade6 in our case) using the following command:
 

```
ADDPEXDFN DFN(NBTEST) TYPE(*PROFILE) PRFTYPE(*JOB) JOB((*TRADE6)) MAXSTG(1000000)
INTERVAL(1)
```
3. Start the trace:
  - a. Type the Start PEX (STRPEX) command, and press Enter.
  - b. Enter a session ID (unique name), for example NBTEST96. For Option, select \*NEW. Press Enter.
  - c. In the Filter field, type the PEX definition name (NBTEST), and press Enter. Notice the message that indicates that PEX trace started.
4. Start your application or load tool.
5. When your test is finished, on an i5/OS command line, type the End PEX (ENDPEX) command, and press Enter.
6. Select the trace (NBTEST), and press Enter.
7. Print a PEX Report by running the following command:
 

```
PRTPEXRPT MBR(NBTEST96) LIB(QPEXDATA) TYPE(*PROFILE)
```

8. Issue the Work with Spooled File (WRKSPLF) command. Look for the QVPERPT spooled file, and type option 5 (Display) next to the report. If you have multiple QVPERPT files, verify the member name, which should be equal to your session ID. In our case, it is NBTEST96.
9. In the PEX trace report, search for the JAVAGC indicator if you are using the Classic JVM, or search for libj9gc23 if you are using IBM Technology for Java VM, as shown in Figure 9-38. In our first test garbage collection, CPU utilization is 16.9%. Values up to around 10% are generally considered acceptable; however, beyond this and application response times and throughput might be impacted.

	Cnt	Histogram		Hit	Hit	Cum	Start	Map	Stmt	Name
		%	%	Addr	Hit	Flag	Nbr			
*****	9485	28.7	28.7	00000000313103F0	==		0			
*****	5597	16.9	45.6	00000000D0B66190	+=		0	libj9gc23.so		
**	1956	5.9	51.5	00000000D068B1F0	+=		0	libj9jit23.so		
*	1206	3.6	55.1	00000000D004B970	+=		0	libc.a(shr.o)		
	888	2.7	57.8	00000000D0DA7DD0	+=		0	libjdbcj9.so		
	819	2.5	60.3	00000000D04B48DC	+=		0	libj9vm23.so		
	506	1.5	61.8	00000000D02B9004	+=		0	libpthreads.a(shr_xpg5.o)		
	430	1.3	63.1	0E47317CAF031928	==		0	QSQCLI		
	404	1.2	64.3	FFFFFFFFF041874	==		0A1804	QUGATEBH		
	392	1.2	65.5	12C158F395034E10	==		0	QPOFEPFS		
	309	0.9	66.4	09F31E18DF031EDC	==		0	QPOLLFS1		

Figure 9-38 PEX Profile output

**Important:** When you review your printed output make sure you look at the Profile Information section of the output. In our case, the Profile Information section was on page 10 out of 18.

## 9.6 Using Tivoli Performance Viewer with WebSphere Application Server

The Tivoli Performance Viewer (TPV) provides information to help tune your WebSphere environment for optimal performance. Tivoli Performance Viewer is the way to view the internal pools and queues that can affect performance within WebSphere Application Server.

The information that TPV shows is useful in detecting performance bottlenecks or slow Enterprise JavaBeans (EJB), JavaServer Pages (JSP), and Java servlets. TPV can display information about the number of Web container threads currently in use, as well as how many are available in the pool. If the number of available threads in the pool is zero, the threads of execution have to wait for a Web container thread to become available.

The Web container pool is just one of the things that TPV can monitor. Other things that TPV can monitor include:

- ▶ DataSource connection pools and prepared statement cache
- ▶ EJB, Servlet, and JSP response times
- ▶ Current heap sizes, available memory, and used memory
- ▶ Many other internal pools

## 9.6.1 Monitoring thread pools

Each running WebSphere Application Server instance contains a Web container. The HTTP requests are routed to a transport queue between the Web server plug-in and the Web container. The Default Web container properties are set for simple Web applications. However, these values might not be appropriate for more complex Web applications. Therefore, you might have to adjust these parameters to tune the Web container based on the specific needs of your environment.

### Thread pool

The thread pool setting within the Web Container determines the number of clients that your application server can process concurrently. This greatly depends on your system's CPU speed, amount of memory, and number of disk arms.

We recommend that you set the value of the maximum size to handle the peak load on your application server. Set it to a maximum size that is less than or equal to the number of threads that are processing requests in your Web server. A value in the range of 25 to 50 is generally a good starting point for smaller Web applications. Use Tivoli Performance Viewer to monitor the number of threads that are being used to provide you with a better idea on the value that you should set the maximum size value to.

Before you can start performance monitoring using Tivoli Performance Viewer, you must make sure that the Performance Monitoring Infrastructure is enabled. By default it is normally enabled. To check if it is enabled:

1. Access the WebSphere Administrative Console (see 4.2.6, "Accessing the WebSphere Administrative Console" on page 121).
2. Log in.
3. Expand **Monitoring and Tuning**, and click **Performance Monitoring Infrastructure (PMI)**. Select your server name. See Figure 9-39.

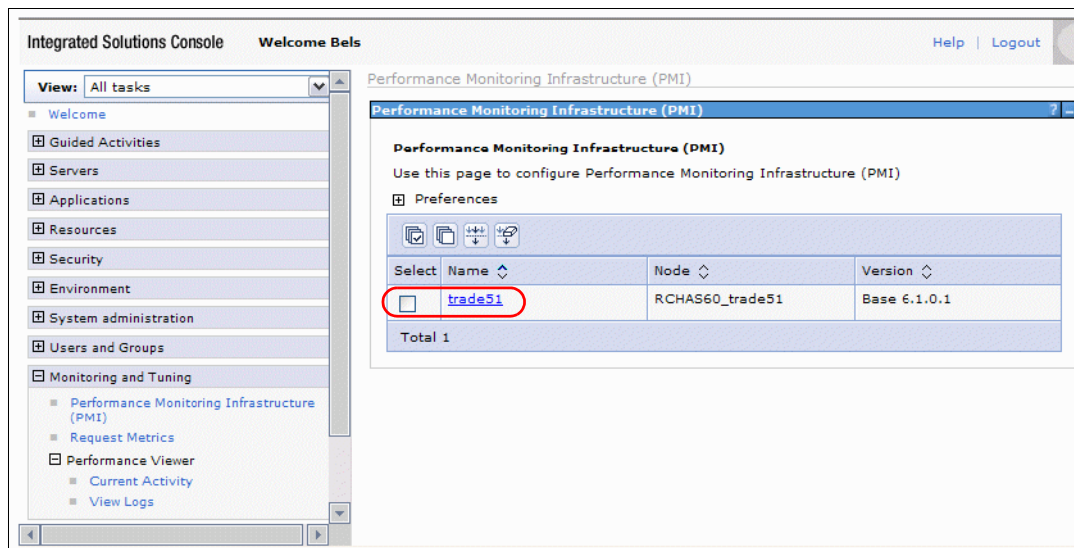

Figure 9-39 Performance Monitoring Infrastructure

4. Verify that PMI is enabled, as shown in Figure 9-40. If it is not enabled, you need to enable it, save your changes, and restart your WebSphere Application Server instance.

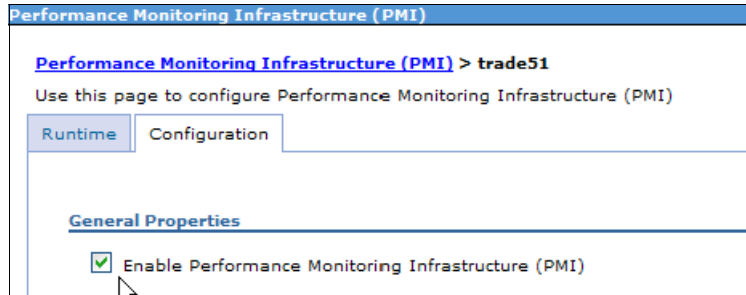

Figure 9-40 Enable Performance Monitoring Infrastructure

To determine your current workload, use Tivoli Performance Viewer to view real-time activity. Access Tivoli Performance Viewer for your thread pool settings by using these steps:

1. After you verify that PMI is enabled, expand **Performance Viewer**, and select **Current Activity**.
2. In the next panel (Figure 9-41), select the check box next to the name of the application server. In this example, we select **trade51**. Click the **Start Monitoring** button to start the collection of data.

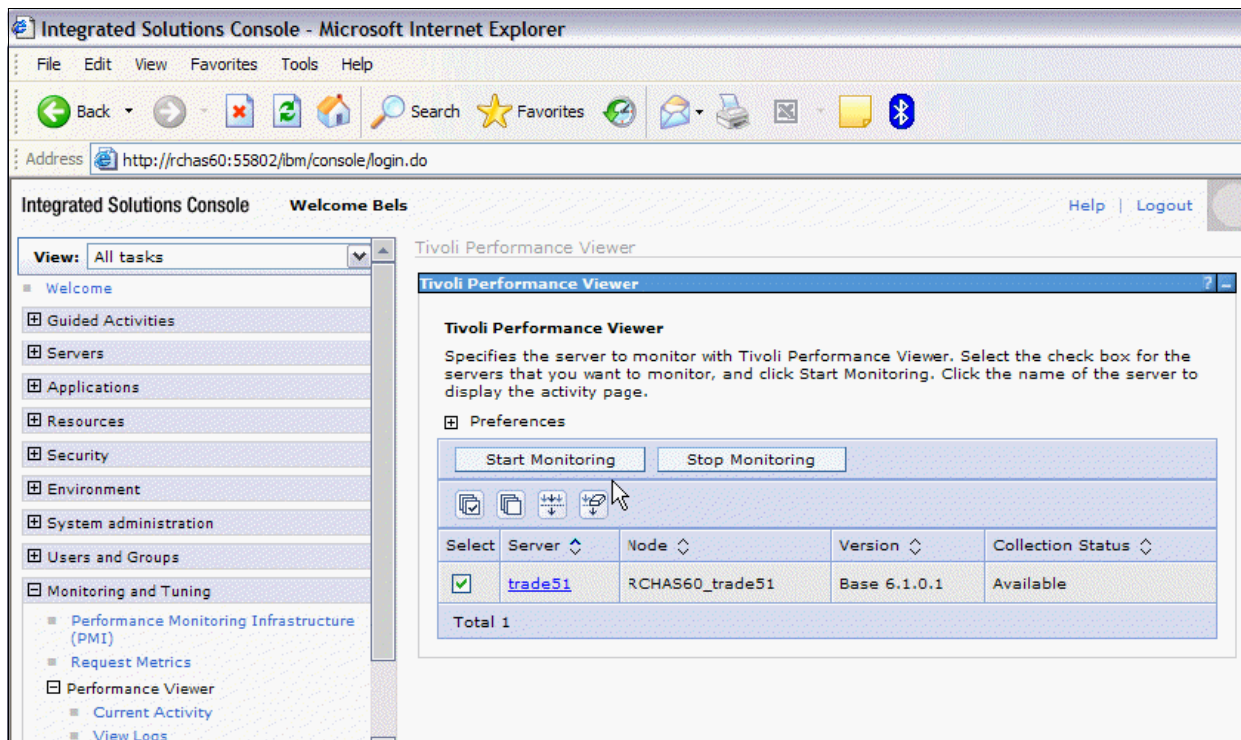

Figure 9-41 Tivoli Performance Viewer Current Activity

3. Click the server name link.

4. As shown in the panel in Figure 9-42, expand **Performance Modules**, and select the **Thread Pools** section.
5. Click the **View Modules** button. Real-time data is displayed in the lower-right panel of your window. If you see a table view, switch to the graphical view by clicking the **View Graph** button.

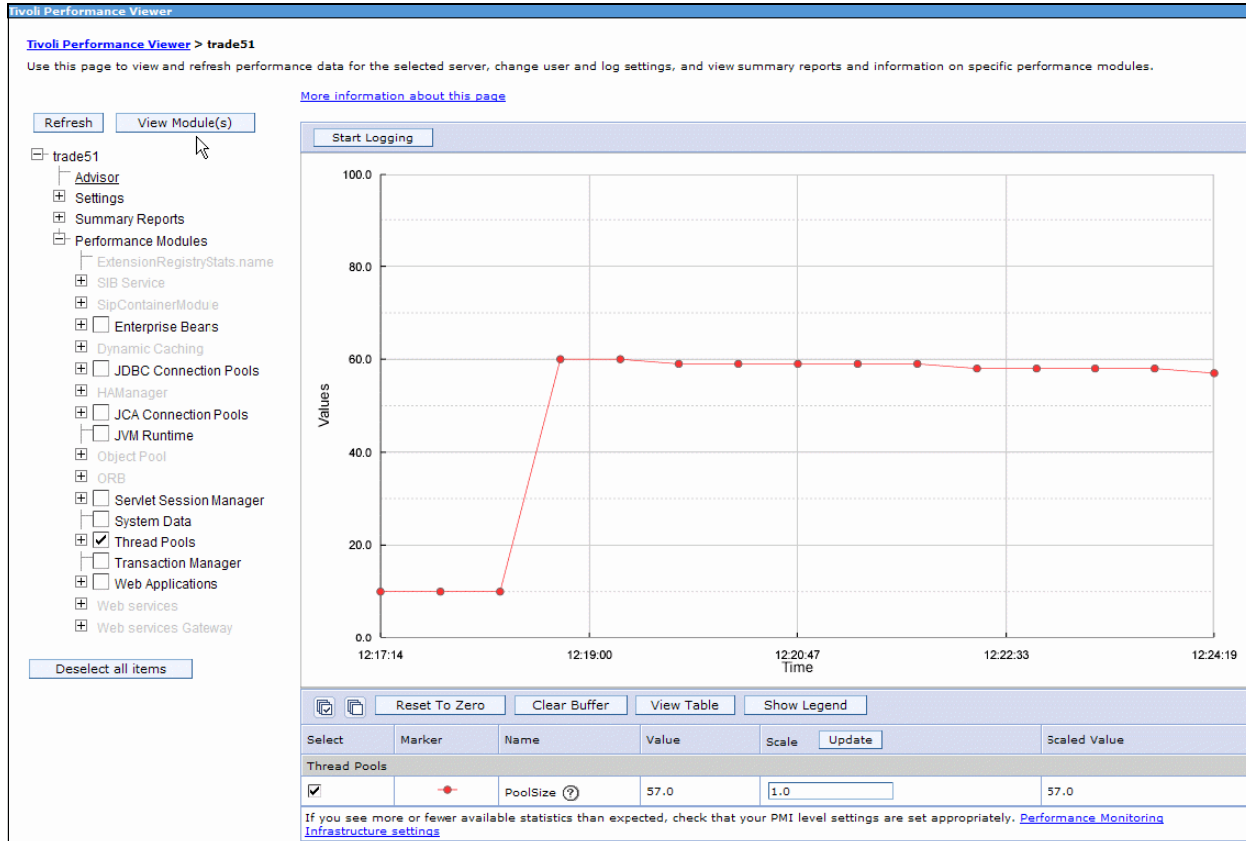

Figure 9-42 Tivoli Performance Viewer - Thread Pools

After you view this information, you should have a good understanding of the size of your thread pool. Repeat this process for several days to obtain a clear picture of the thread activity in your environment.

If the number of active threads is always at the maximum capacity of the pool, increase the maximum size of your pool. However keep in mind, that increasing the pool size places more workload on your system, which, of course, can be a problem if your system does not have the extra capacity to support the additional threads. By keeping the thread pool down, you make the requests wait until a thread is available. This is where you have to balance the resources you have available. It is best to make small changes and review the impact you have as a result.

You should also analyze the effect of this change on the system performance. Most likely, you will re-evaluate your shared pool and JVM runtime settings to make sure that they are still at their optimum level.

To modify your thread pool settings based on the information obtained from Tivoli Performance Viewer:

1. Access the WebSphere Administrative Console (see 4.2.6, “Accessing the WebSphere Administrative Console” on page 121).
2. Log in.

3. In the Navigation frame, expand **Servers**, and click **Application servers**.
4. Click the name of your server, which is **trade51** in our example.
5. In the next panel, click the **Thread Pools** link.
6. In the next panel, click the **WebContainer** link.
7. In the next panel, which shows the thread pool settings (see Figure 9-43), modify the value in the Maximum Size field. Click **OK**.

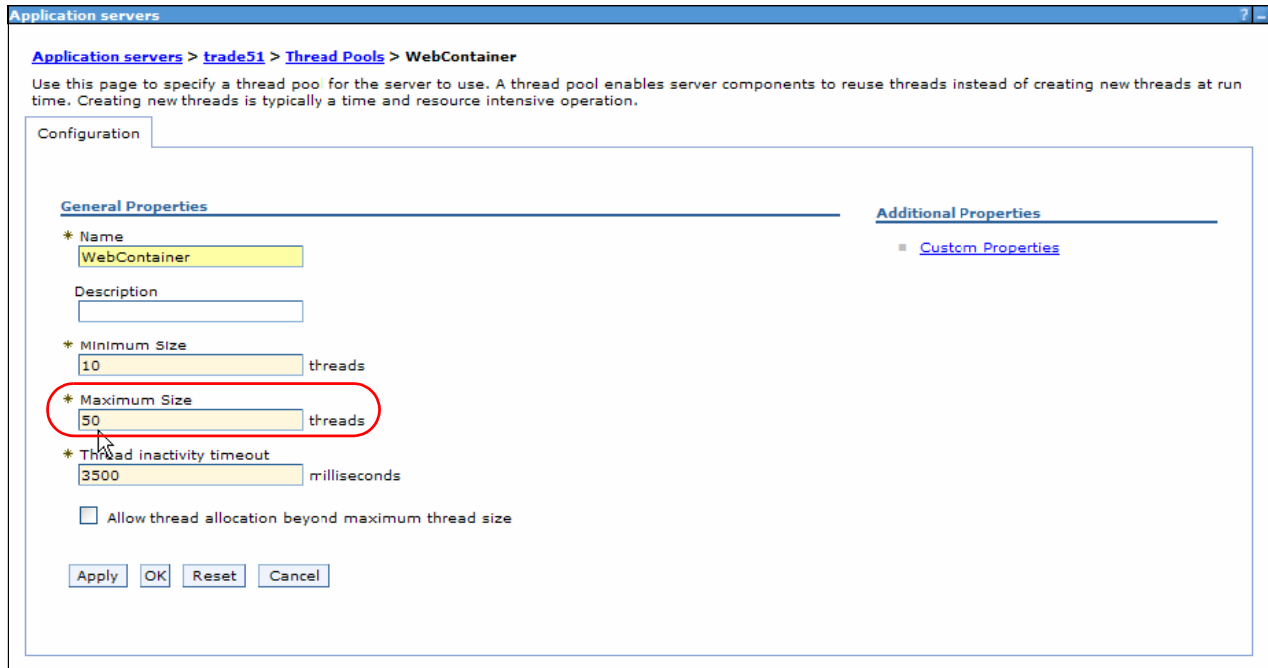

Figure 9-43 Thread pool settings

**Tip:** We recommend that you do not enable the **Allow thread allocation beyond maximum thread size** property, if you are confident that the current maximum size value can adequately process the peak load on your application server.

## 9.6.2 Monitoring the connection pool

The connection pool basically manages the connections to the database and ensures that the connections are used in an efficient manner because establishing a database contention can be an expensive operation. When a user makes a request over the Web to a resource, the resource accesses a data source. Because clients connect and disconnect quite frequently with applications on the Internet, the application requests for data access can increase to a considerably large volume, which results in performance deterioration. However, when connection pooling capabilities are used, Web applications can take advantage of performance improvements of up to 20 times the normal results.

To determine the minimum and maximum number of connections that your application must establish to the database, use the Tivoli Performance Viewer. Tivoli Performance Viewer provides you with a starting point for monitoring the connections usage.

To access the Tivoli Performance Viewer for your connection pool settings:

1. Access the WebSphere Administrative Console (see 4.2.6, “Accessing the WebSphere Administrative Console” on page 121).
2. Log in.
3. Expand **Monitoring and Tuning** → **Performance Viewer**, and click **Current Activity** (see Figure 9-41 on page 334).
4. In the next panel, select the name of the application server by placing a check mark in the **Select column**. Click the **Start Monitoring** button to start the collection of data (see Figure 9-41 on page 334).
5. Click the server name link.
6. In the panel that opens (Figure 9-44), expand **Performance Modules**. Select the appropriate JDBC Driver for your application to monitor. In our example, we select **DB2 UDB for iSeries**. Place a check mark in the boxes located next to the components for which you want to monitor, and click **View Module(s)**.

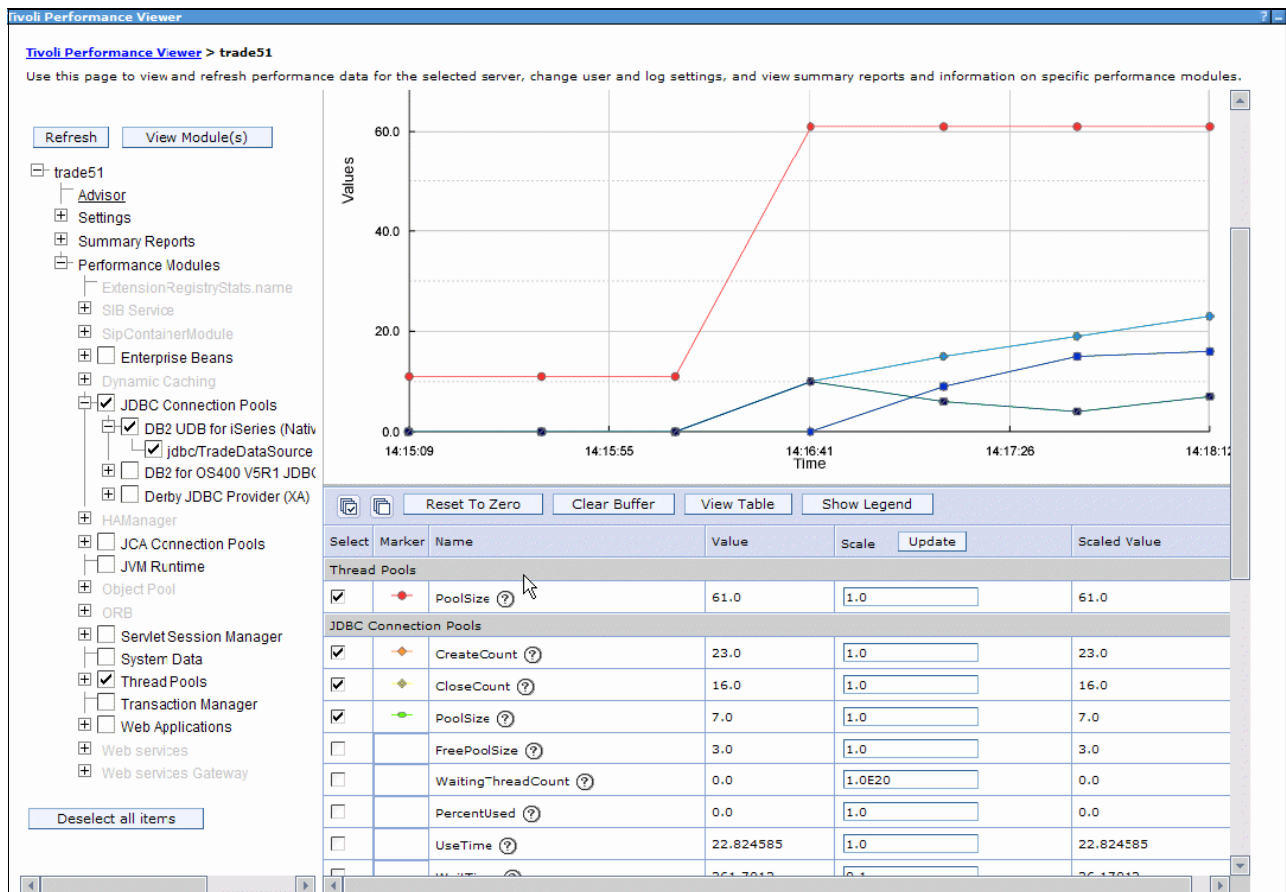

Figure 9-44 Tivoli Performance Viewer - database connections

7. A window opens showing the number of connections that are being used, which should give you an idea on the number of connections that your application is presently using. In particular, watch for any threads that are waiting for connections, as shown by the **Waiting Thread Count** display. If this number is increasing, you might have to increase the number of connections that are available, or there may be a database problem. Perform this monitoring for several days to give you the best possible idea on the average amount of connections that are being established.

**Note:** You can select additional parameters to be plotted on the graph by selecting the appropriate check box in the lower part of the TPV graph.

8. With that information, you are ready to update the connection pool (if required). Expand **Resources**, and click **JDBC Providers**.
9. Select the name of your JDBC provider, which in our case is **DB2 UDB for iSeries**.
10. In the next panel, click the **Data Sources** link.
11. In the next panel, click the **Connection pool properties** link.
12. Modify the value in the Maximum connections field (Figure 9-45).

The screenshot shows a web-based configuration interface for 'JDBC providers'. The breadcrumb trail at the top reads: 'JDBC providers > DB2 UDB for iSeries (Native XA - V5R2 and later) > Data sources > TradeDataSource > Connection pools'. Below the breadcrumb is a warning message: 'Use this page to set properties that impact the timing of connection management tasks, which can affect the performance of your application. Consider the default values carefully; your application requirements might warrant changing these values.' The main configuration area is titled 'Configuration' and is divided into two columns: 'General Properties' and 'Additional Properties'. Under 'General Properties', there are several input fields: 'Scope' (text box with 'cells:RCHAS60\_trade51;nodes:RCHAS60\_trade51'), 'Connection timeout' (text box with '180' and 'seconds' label), 'Maximum connections' (text box with '10' and 'connections' label, circled in red), 'Minimum connections' (text box with '1' and 'connections' label), 'Reap time' (text box with '180' and 'seconds' label), 'Unused timeout' (text box with '1800' and 'seconds' label), 'Aged timeout' (text box with '0' and 'seconds' label), and 'Purge policy' (dropdown menu with 'EntirePool' selected). Under 'Additional Properties', there are two checkboxes: 'Advanced connection pool properties' and 'Connection pool custom properties', both of which are unchecked. At the bottom of the configuration area are four buttons: 'Apply', 'OK', 'Reset', and 'Cancel'.

Figure 9-45 Connection pool settings

### 9.6.3 JDBC performance considerations

Two JDBC drivers are available for DB2 Universal Database for iSeries: the Native driver and the IBM Toolbox driver. The Native JDBC driver is a part of the System i Classic JVM and performs better than the Toolbox JDBC driver. However, you can only use the Native JDBC driver if your application and database are on the same server.

The Toolbox driver runs on local or remote (to the database location) JVM. Currently, we recommend that when you are running on the System i server directly, use the Native JDBC driver. When your program runs from another JVM and will access the System i server remotely, use the Toolbox driver.

The best advice is to avoid hard coding your program to use a specific JDBC driver. Instead, make the JDBC driver configurable at run time by using data sources in your program. You can then specify the JDBC driver that makes sense in your environment.

## 9.7 Web performance management tools

Two new Web performance management tools are available for WebSphere performance:

- ▶ Web Performance Monitor
- ▶ Web Performance Advisor

**Important:** Whenever you use new WebSphere Application Server-based functions, we recommend that you ensure that you have the latest available sets of PTFs (fixes) in the following component areas:

- ▶ The latest cumulative PTFs for your i5/OS version
- ▶ The following PTF groups for the corresponding i5/OS release:
  - The latest Java PTF groups.
  - The latest DB2 Universal Database for i5/OS PTF groups.
  - The latest HTTP PTF groups.
  - The latest WebSphere PTF groups for your WebSphere Application Server version and product these two Web performance tools support. Support for WebSphere Application Server 6.1.x was introduced in April 2007.

Both of these tools are accessed from IBM Web Administration for i5/OS. This product has been available for many i5/OS releases and continues to get enhanced with each new i5/OS release and frequently within a release cycle.

You can start this Web Administration for i5/OS server using either of the following methods:

- ▶ By the Start TCP/IP Server command `STRTCPSVR SERVER(*HTTP) HTTPSVR(*ADMIN)`.
  - ▶ By the iSeries Navigator interface (**systemname** → **Network** → **Servers** → **HTTP Administration**).
  - ▶ By specifying \*YES for the Autostart (AUTOSTART) parameter of the Change HTTP Attributes (CHGHTTTPA) command, which tells i5/OS to automatically start the HTTP server when TCP/IP is started by the Start CTP/IP (STRTCP) command.
1. Although you can change the default for port number, you typically access the i5/OS Administration server by entering the following from your browser:  
`http://hostname:2001`
  2. On the i5/OS Tasks page, select the **IBM Web Administration for i5/OS** link.
  3. Select the **Manage** tab.
  4. Select the **Application Servers** tab.
  5. From the next window, which shows all of the defined servers, select a specific application server that you want to use with the Web Performance Monitor or the Web Performance Advisor.
  6. For that server, click the **Manage Details** button to get the window to show the monitor or the advisor links.

7. Click either the Web Performance Monitor or the Web Performance Advisor link in the lower-left Navigation area.
8. In our example in Figure 9-46, we selected **WEAPPSVR**. You see the links to the Web Performance Advisor and Web Performance Monitor. Click either link shown.

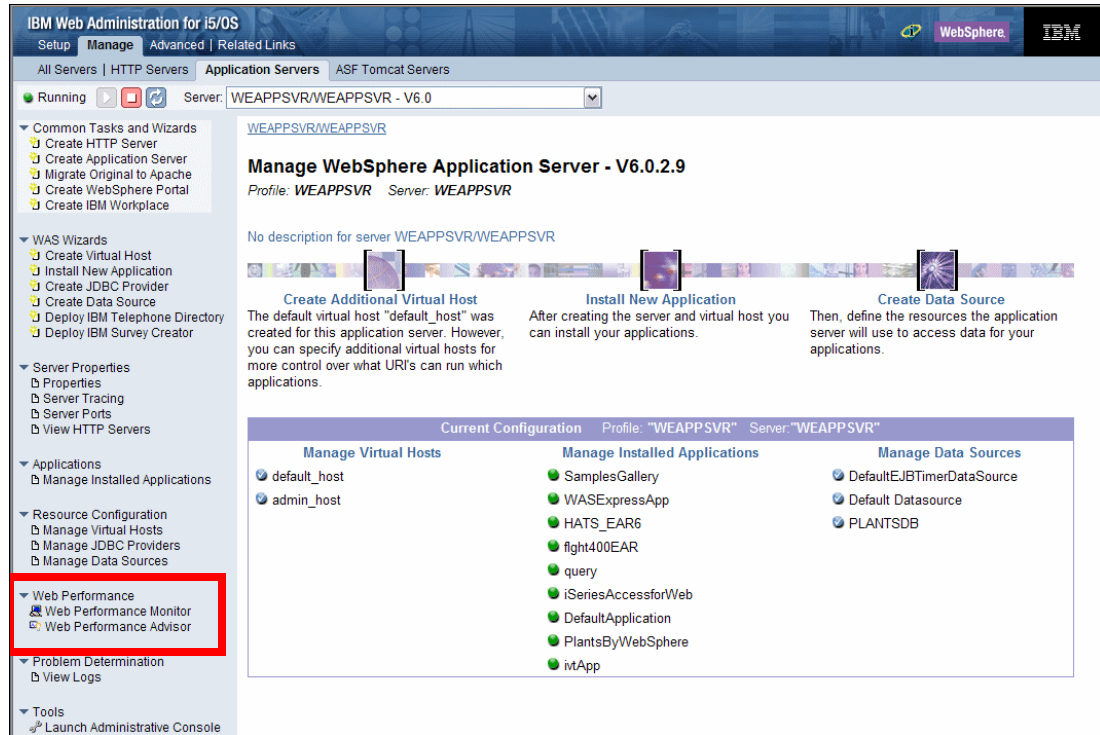

Figure 9-46 Accessing the Web Performance Monitor and Performance Advisor

### Important:

- ▶ The Web Performance Advisor supports WebSphere Application Server 5.0.x and later servers, Portal, and Workplace™.
- ▶ The Web Performance Monitor supports WebSphere Application Server 5.1.1.x and later servers.

If either of these tools does not support the version of the server you chose, the link does not display.

The following sections provide additional overview information about these two performance management tools.

## 9.7.1 Web Performance Monitor

The Web Performance Monitor collects unique Web application performance and transaction data for just the jobs that comprise the selected Web environment, which includes the HTTP server, application server, and associated database jobs that are used by WebSphere applications that are running in the selected application server.

The data collection is performed by gathering performance data that is generated by the Application Response Measurement 4.0 (ARM) instrumentation, which is already shipped with:

- ▶ HTTP Web servers from IBM
- ▶ WebSphere Application Server, versions starting with V5.1.1.x through V 6.1.x
- ▶ DB2 Universal Data Base for i5/OS

ARM is a standard of The Open Group:

<http://www.opengroup.org>

The ARM is composed of a set of APIs that you can use to collect response time information for enterprise applications. The ARMs were originally instrumented for use with WebSphere Enterprise Workload Manager™ (EWLM).

EWLM monitors and records activities across multiple system (partition) and operating system environments, whereas, the Web Performance Monitor monitors a single i5/OS partition.

Overhead is introduced to your WebSphere transactions while the monitor is running, so you typically do not run the monitor during multiple user production mode. You use it to understand the performance characteristics of your WebSphere application and associated HTTP server and application server. You are looking for long response times or high transaction counts for certain transactions or functions that are relative to others that are performed by the actual application.

For test purposes, with only a few WebSphere application users active, the overhead is barely noticeable.

This new monitor information can help to identify the number of Web-based transactions and average transaction response times over the time period of collection, and the relative amount of time that is spent within sub portions of a transaction, such as within the HTTP server, within the Web applications, and within the database functions of transactions if the applications are using WebSphere Application Server data source interfaces.

Understanding the components of transaction processing becomes especially important when applications consist of many jobs and threads that are running within a single system and on multiple systems, such as when the database functions and application processing functions are performed on different systems.

The monitor can:

- ▶ Monitor end-to-end performance.
- ▶ Provide a WRKACTJOB-like level of information about the initial window (that can be refreshed).
- ▶ Provide job-level and transaction-level statistics among the selected HTTP server, WebSphere Application Server applications, and, optionally, any data source access by the applications to DB2 for i5/OS database server jobs.
- ▶ Provide more detailed job management functions by linking to optionally started iSeries Navigator tasks on the Web.

Perform the following to run the Web Performance Monitor:

1. Access IBM Web Administration for i5/OS from your browser, and select a specific application server.
2. For that server, select the **Manage Details** button. Click the **Web Performance Monitor** link at the left of the details page. The browser opens the Web Performance Monitor page, as shown in Figure 9-47.

In our example, we use the HTTP server WEHTTPSVR and WebSphere Application Server profile/server WEAPPSVR, which we had the wizard of the IBM Express Runtime Web Environments for i5/OS create for us (see instructions in “Installing IBM Express Runtime Web Environments for i5/OS” on page 443).

3. Click the **Start** button. The processing begins. An hourglass is shown in front of the current item and items are checked off as they are completed.

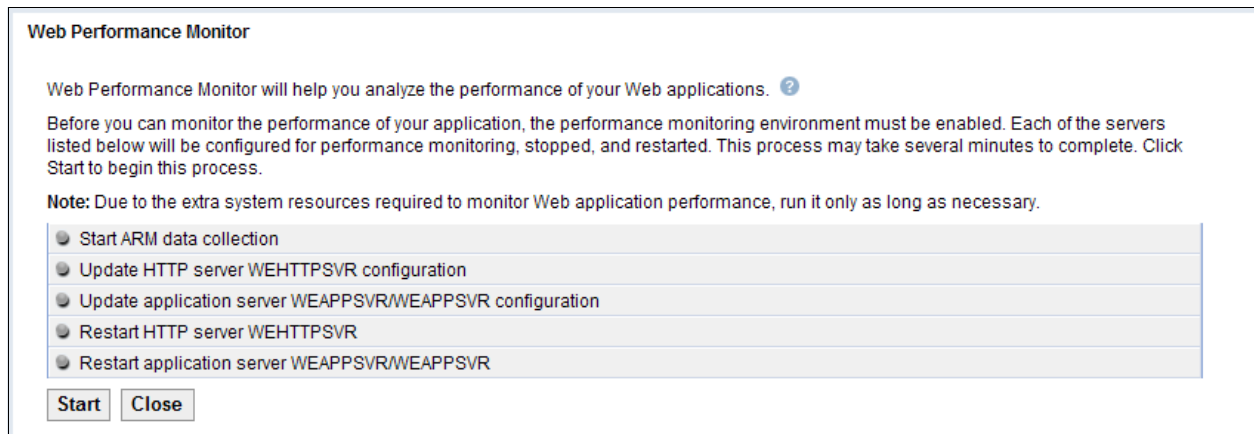

Figure 9-47 Web Performance Monitor - start example

When the start process completes, your HTTP server and WebSphere Application Server instance or profile are enabled for performance monitoring.

The Web Performance Monitor shows the job and transaction statistics for your Web-based jobs as they run on the i5/OS partition. It shows a WRKACTJOB-like window, as shown in Figure 9-48.

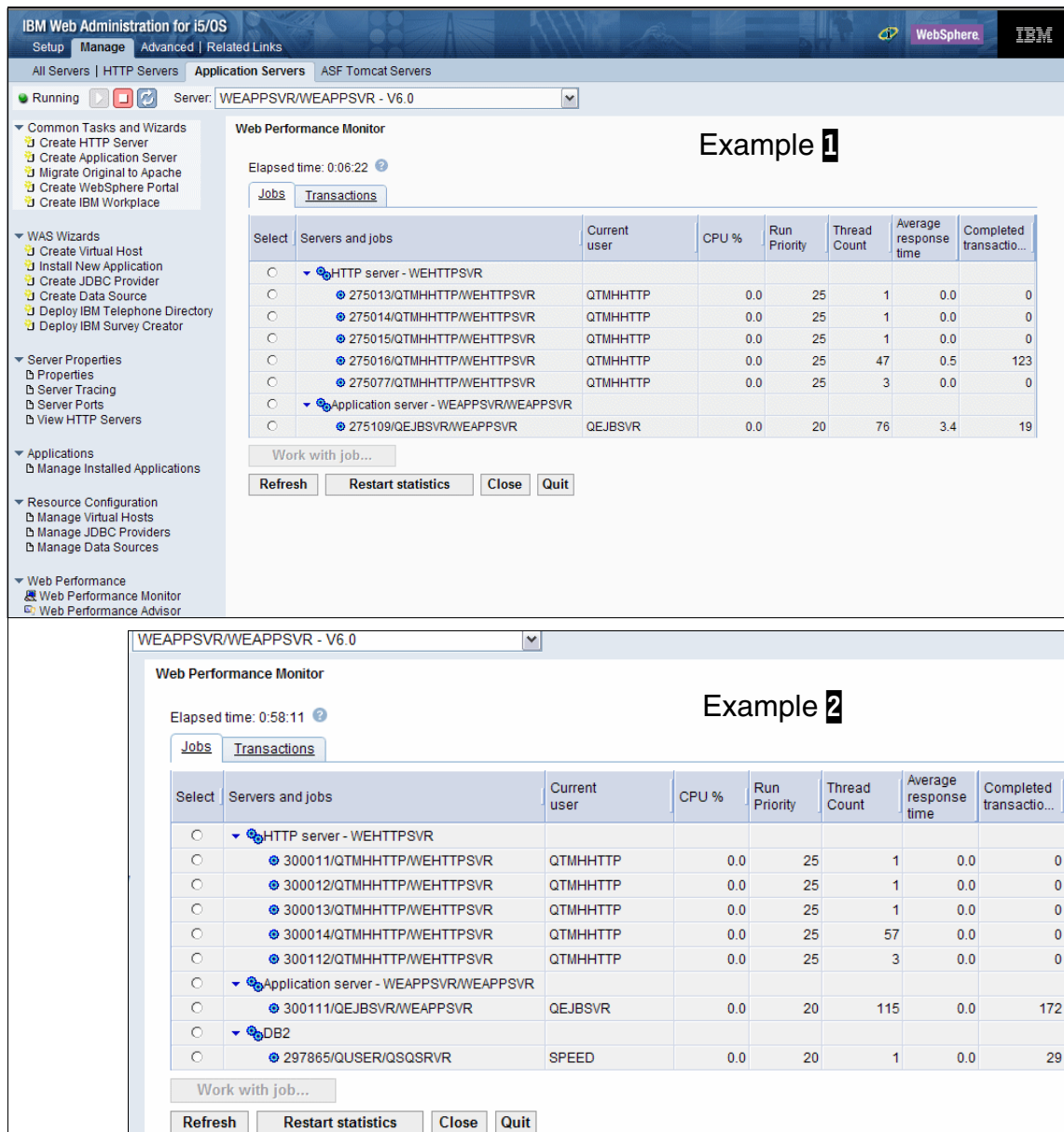

Figure 9-48 Web Performance Monitor - jobs example

If you select a job, the **Work with job** button is activated. If you then select that button, you are launched to the iSeries Navigator tasks on the Web application (included in i5/OS 5722-SS1, Option 3), provided that:

- ▶ On V5R4, you started the WebSphere Application Server server or profile SYSINST/ADMIN.
- ▶ On V5R4, you have PTF SI24255 installed. With this PTF installed, iSeries Navigator tasks on the Web runs in the integrated Web application server.

iSeries Navigator tasks on the Web provide a large subset of the iSeries Access for Windows iSeries Navigator functions from a browser interface rather than from a Windows workstation iSeries Navigator interface. Displaying active job information is one of its functions.

If this application is not activated, you will get an error window. To learn more about iSeries Navigator tasks on the Web, refer to the IBM Redbooks publication *IBM System i5 V5R4 Technical Overview Redbook*, SG24-7271.

You can also show a transactions view of the performance information by clicking the **Transactions** tab. We do not show an example of the Transactions window in this book, but in that view you can specify preferences and user filtering to control what is shown on the screens, for example, show only the activity for user USERxxx.

In our jobs example windows, which we show in Figure 9-48 on page 343, you see very little CPU utilization, but some work occurred as evidenced by:

- ▶ HTTP server job 275016 has processed 123 requests (completed transactions).
- ▶ The associated WebSphere Application Server job - 275109 has processed 19 completed transactions with an average response time of 3.4 seconds.

Further discussion of the reported metrics and how to best use the Web Performance Monitor is beyond the scope of this book. However, it is apparent that you need to be able to work with someone who understands the application implementation in order to productively use the statistics that are presented to you. You also must be aware of the following:

- ▶ One browser request (mouse click, function, or Enter key) sent to the system results in one request being sent through the HTTP server. However, often the response to the request contains links to files (such as images) to be part of the user's view of the response. This results in the browser sending additional requests to the HTTP server that may be handled within the HTTP server or routed to a processing program. These additional requests and response pairs are counted as a separate transaction even if they do not get processed by the application program, such as the flight400 application.
- ▶ One effect of this, as shown in our example 1 window, is that the HTTP transaction counts are higher than the WebSphere Application Server counts, and HTTP server average response times are lower than the WebSphere Application Server average response time.
- ▶ An application, such as the trade application that we installed in WEAPPSVR, can be run with a port number such that the browser request goes directly to the application server. That is, the request and response are never processed by the HTTP server (WEHTTPSVR, in our example). Therefore, there is no associated increase in transaction counts for the HTTP server, although there could be an increase in the application server statistic values. We show an example of this in our example 2 window in Figure 9-48 on page 343. This example shows an application server transaction count of 172, but zero transactions for our HTTP server.
- ▶ In our two example windows, you see that example 1 does not show any associated i5/OS DB2 database server job metrics, while example 2 does show some DB2 database server statistics. You may see an associated database server job (QSQRV jobname prefix or QZDASOINIT job name prefix) depending on how your application interfaces to DB2 for i5/OS.

Under i5/OS, an application can access the i5/OS database with any of the following hierarchical level interfaces, starting with the application layer at the lowest level:

- Application layer: On i5/OS, this can implicitly or explicitly be:
  - Native file level, non-SQL interface (open file, read, write, update, delete, and so on).

- SQL, application level interface (SELECT, and so forth), no interface through a JDBC Provider.
  - JDBC Provider - Data Source, using the i5/OS-unique native JDBC driver. This driver is unique to i5/OS and is often referred to as *DB2 UDB for iSeries (Native XA)*. This interface performs all SQL functions under one of the associated i5/OS database server jobs with the QSQRVR job name prefix.
  - JDBC Provider - Data Source using the industry standard for database access driver. On i5/OS, this is known as the Java toolbox driver interface and performs all SQL functions under one of the associated i5/OS database server jobs with the QZDASOINIT job name prefix.
- WebSphere Application Server Server layer:
    - JDBC Provider - Data Source using the i5/OS-unique native JDBC driver (under the QSQRVR job name prefix).
    - JDBC Provider - Data Source using the industry standard for database access driver (under the QSQRVR job name prefix).
  - WebSphere Application Server Node layer:
    - JDBC Provider - Data Source using the i5/OS-unique native JDBC driver (under the QSQRVR job name prefix).
    - JDBC Provider - Data Source using the industry standard for database access driver (under the QSQRVR job name prefix).
  - WebSphere Application Server Cell layer:
    - JDBC Provider - Data Source using the i5/OS-unique native JDBC driver (under the QSQRVR job name prefix).
    - JDBC Provider - Data Source using the industry standard for database access driver (under the QSQRVR job name prefix).

In example 2, we included transactions that are performed by the Trade (stock transaction) application, which is used as a WebSphere Application Server benchmark within IBM. This application uses the *DB2 UDB for iSeries (Native XA)* JDBC Provider - Data Source, defined at the node level.

Use the WebSphere Administrative Console interface to your WebSphere Application Server server - profile → **JDBC Providers** link to view what is defined.

- ▶ For now, it seems clear that if browser users have a response time concern and you see high average response time for the WebSphere Application Server application, the primary contributor to the high response time is at the application level. The performance problem could be in the area of database access, but you need to use other i5/OS-based performance tools to analyze this area.
- ▶ After you look at the monitor statistics, you may next consider looking at current i5/OS system values, WebSphere Application Server values, and the efficiency of the application itself. This leads us to the Web Performance Advisor topic after we end the currently active Web Performance Monitor in our example scenario.

To end the Web Performance Monitor, click **Quit** on the Jobs (shown in Figure 9-48 on page 343) or the Transactions window. This brings up the window shown in Figure 9-49. Click **Stop**.

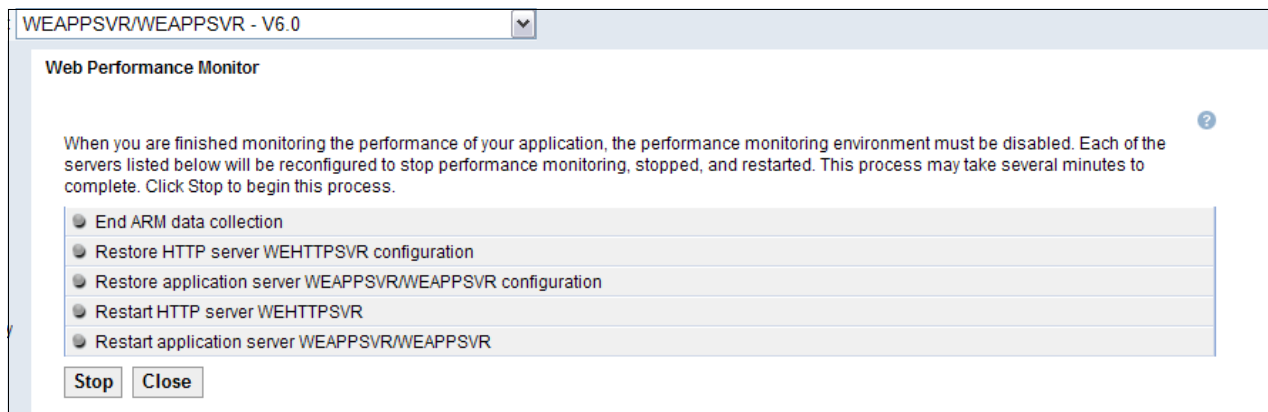

Figure 9-49 Ending the Web Performance Monitor

You can watch progress check marks as each step is completed. When complete, your HTTP server and associated application server are back up and running without the monitoring capability enabled.

## 9.7.2 Web Performance Advisor

The Web Performance Advisor was made available during November 2006 with PTF SF99114. This advisor is unique to i5/OS. It provides a set of wizards and attribute management tools that you can use to evaluate and improve the performance of a Web environment.

One of the primary advantages of using this advisor tool, which you can invoke in real time during normal workload operations, is that it interrogates the named WebSphere Application Server instance and extracts several parameter values that affect performance and presents them all in a single, easily accessible interface, which minimizes the typical number of mouse clicks that are needed to find this information using the WebSphere Application Server profile's Administrative Console interface.

The primary advisor capabilities include:

- ▶ Doing a quick analysis of your Web performance-related i5/OS system values, HTTP server configuration parameters, and WebSphere Application Server profile configuration parameters. Based on the evaluation, it indicates, within an area, if some changes are suggested to improve performance. If there are recommended values to change to, they are presented to you. The analysis and recommended values are based upon experience by Rochester IBM System i performance experts.
- ▶ Managing the performance attributes that are analyzed, which allows you to view and modify all of the attributes that can have a significant impact on the performance of a Web environment, such as:
  - View and modify the value.
  - View the current value's rating. (Is this value acceptable?)
  - View and set the recommended value.
- ▶ Importing and exporting the performance attributes: Saves the performance attributes to an xml file that can be sent to IBM or an ISV for additional performance analysis. The IBM or the ISV representative can update the XML file and return it to you. Assuming that you

agree on the updated attribute values, these updates can then be imported into your Web environment.

To start the Web Performance Advisor, you have to use the IBM Web Administration for i5/OS management of application servers interface to select the specific WebSphere Application Server profile - server. Select **Manage Details**, and then click the **Web Performance Advisor** link (shown in Figure 9-46 on page 340). You then get the initial advisor window shown in Figure 9-50.

You can see some system attributes and buttons to link to further information and guided assistance:

- ▶ Manage system attributes.
- ▶ Manage application server and HTTP server attributes.
- ▶ Export or import the performance profile (xml file).

You can also see an indication of the initial evaluation that was performed, as indicated by the text and exclamation point icons in our example, as shown in Figure 9-50. Our example shows WebSphere Application Server WEAPPSVR and HTTP server WEHTTSPVR.

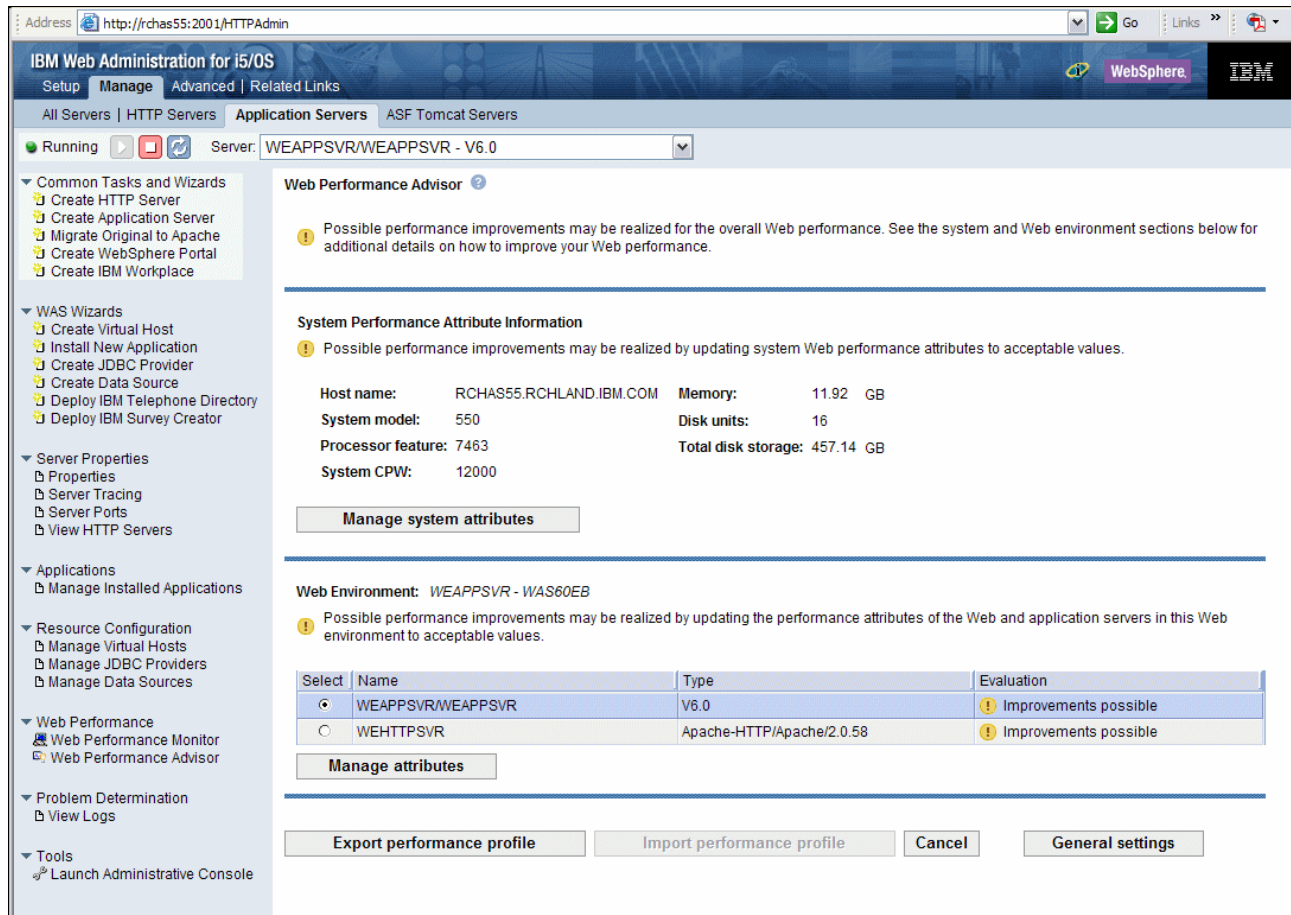

Figure 9-50 Web Performance Advisor - initial window

The exclamation point icons indicate that the Advisor considers that there are some parameters that, if changed, could improve performance.

You can view all of the servers that comprise the current environment, review their performance parameter settings, and select and manage individual attributes that affect server performance.

This first page gives a good overview of the entire machine because it shows the host name, system model, processor feature, system CPW, memory, number of disk units, and total amount of disk.

Rchas55 is a partition. The host name, memory size, disk units, and total disk storage are for the Rchas55 partition. Other values are system wide. Processor feature 7463 indicates that this is an Enterprise Edition (full 5250 CPW capacity).

We looked up feature 7463 in all of the following documents to determine that 7463 is an Enterprise edition:

- ▶ *System i Performance Capabilities Reference i5/OS Version 5, Release 4*
- ▶ *IBM System i5 Handbook: IBM i5/OS Version 5 Release 4, SG24-7486-00*
- ▶ *IBM System i5, eServer i5, and iSeries Systems Builder IBM i5/OS Version 5 Release 4 - January 2006, SG24-2155*

Using the Display System Value (DSPSYSVAL) for system value QPRCFEAT also shows 7463 on our example system (partition).

Figure 9-51 shows an example of the information under the System Resources tab with *advise links*. You can review and consider making changes to its associated parameter. You also see a tab for performance settings and also the PTF Groups tab and the Web PTFs tab.

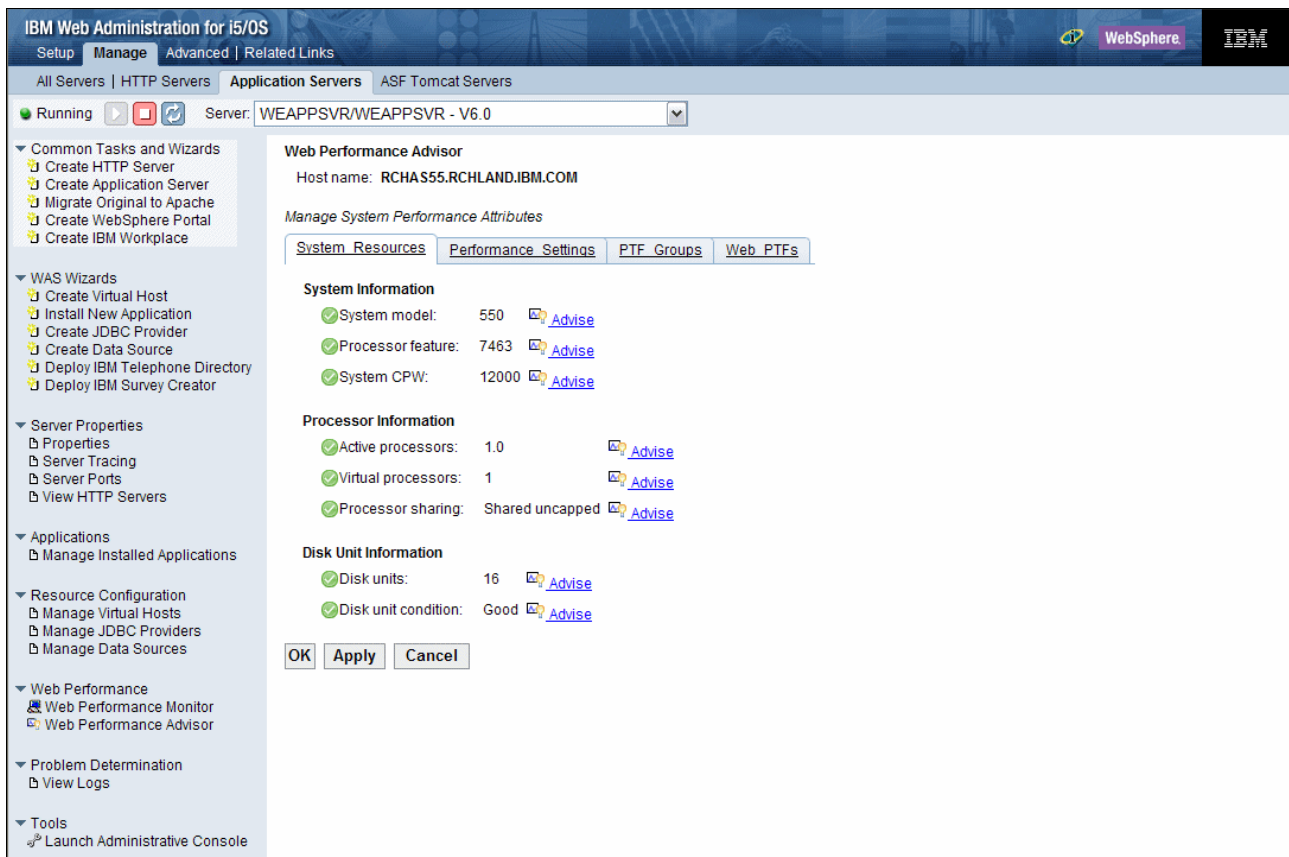

Figure 9-51 Web Performance Advisor - manage system attributes example

The PTF tabs provide a summary level list of PTFs, as illustrated in Figure 9-52.

The screenshot displays the Web Performance Advisor interface for host RCHAS55.RCHLAND.IBM.COM. It features two main panels. The top panel, titled "PTF Groups", shows a table of installed and unknown PTFs. The bottom panel, titled "Web Product PTFs", shows a list of PTFs for various Web products, each with a status column.

**PTF Groups Table:**

PTF Group	Level	Status	Description
SF99540	6192	Installed	CUMULATIVE PTF PACKAGE C6192540
SF99539	27	Installed	GROUP HIPER
SF99504	4	Installed	DB2 UDB FOR ISERIES
SF99322	3	Unknown	WEBSPPHERE APP SERVER V6.1
SF99315	3	Installed	TCP/IP GROUP PTF
SF99312	7	Installed	WEBSPPHERE APP SERVER V6.0
SF99303	3	Not applicable	WEBSPPHERE MQ FOR ISERIES - V6.0
SF99301	17	Unknown	WEBSPPHERE APP SERVER V6.0

**Web Product PTFs Table:**

PTF Information	Status
▶ 5722DG1 -- IBM HTTP Server for i5/OS	
▶ 5722DG1 -- Triggered Cache Manager	
▶ 5722JV1 -- Java Developer Kit 1.3	
▶ 5722JV1 -- Java Developer Kit 1.4	
▶ 5722JV1 -- Java Developer Kit 5.0	
▶ 5722JV1 -- J2SE 5.0 32 bit	
▶ 5733W60 -- WebSphere Application Server for OS/400 V6	
▶ 5733W60 -- WebSphere Application Server V6 ("Base")	
▶ 5733W60 -- WebSphere Application Server V6 Network Deploy	
▶ 5722999 -- Licensed Internal Code	
▶ 5722SS1 -- i5/OS	
▶ 5722SS1 -- Extended Base Support	
▶ 5722SS1 -- Online Information	
▶ 5722SS1 -- Extended Base Directory Support	
▶ 5722SS1 -- Example Tools Library	
▶ 5722SS1 -- Host Servers	
▶ 5722SS1 -- System Openness Includes	
▶ 5722SS1 -- ObjectConnect	
▶ 5722SS1 -- Integrated Server Support	
▶ 5722SS1 -- Qshell	
▶ 5722SS1 -- Domain Name System	
▶ 5722SS1 -- Portable App Solutions Environment	
▶ 5722SS1 -- Digital Certificate Manager	

Figure 9-52 Web Performance Advisor: PTF groups and Web product PTFs

You can click the arrow to the left of each Web product and see the list and status of that product's PTFs that are installed on the partition.

Click the **System Resources** tab. On that Web page, click the **Advise** link, which is located next to a parameter and the Advisor presents an Advise window. Figure 9-53 shows examples of the Advise windows for several of the partition's system resource parameters.



Figure 9-53 Example of system resources advice

You see a recommended value in our examples but no capability to change a setting. The settings shown in our example need to be changed outside of the Web Performance Advisor, for example, the number of virtual processors on our 550 model can be changed using the Hardware Management Console (HMC) interface.

In the figures that follow, we show examples of the Performance Settings tab Advise windows and the capability to make changes. Depending upon the actual parameter and the software affected by that value of that parameter, you might be able to make a change in real time or not be able to change the value immediately. The Advise window explains this.

Figure 9-54 shows an example of the output that you get after you select the Performance Settings tab. The Performance adjustment setting and the TCP/IP Buffer Sizes are highlighted in this case, as they are out of line with recommendations. You can click the **Advise** link to get detailed information about the recommended settings.

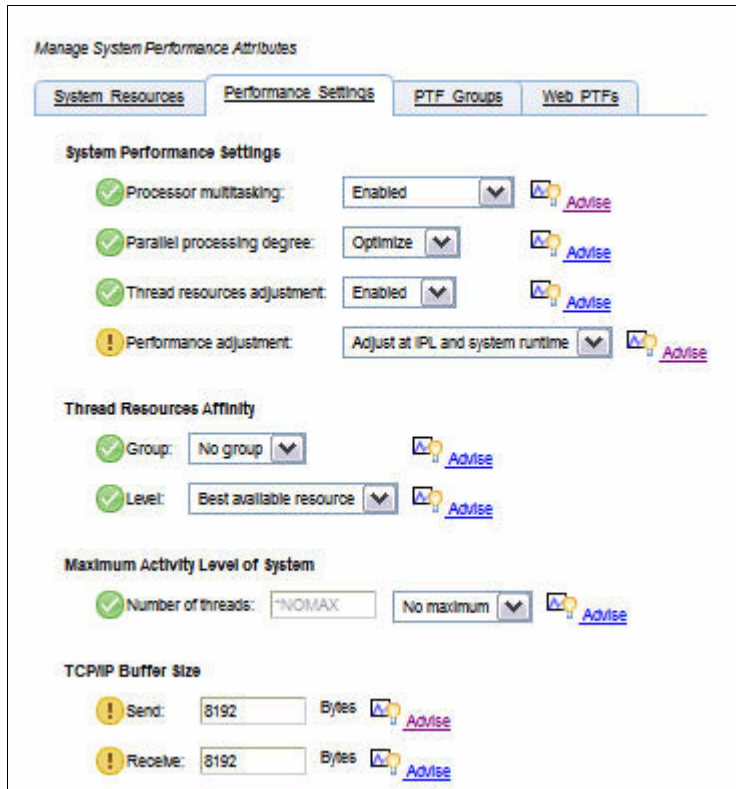

Figure 9-54 Web advisor - Performance Settings list

We selected to get the advise information about the performance adjustment parameter, the TCP/IP send buffer size, and the parallel processing degree (for queries) values, as shown in Figure 9-55 on page 352.

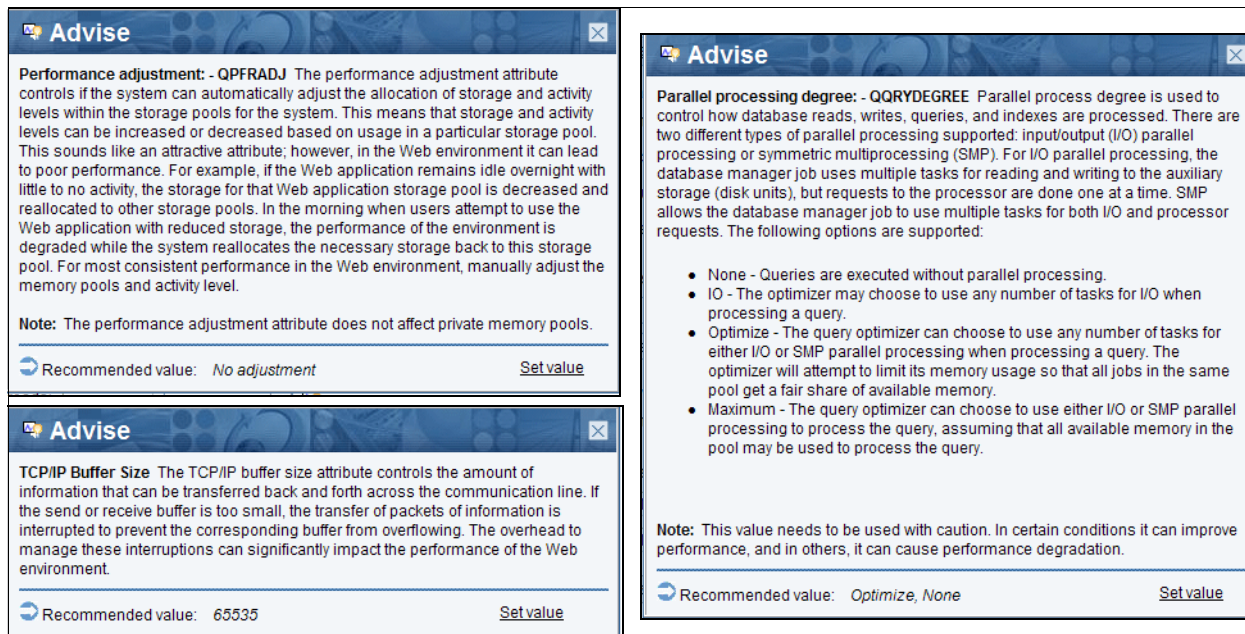

Figure 9-55 Performance Settings Advise examples: TCP/IP buffer, query parallel processing

Review the Advise window text. Each window has a set value link. Each time you click the **Set value** link you are returned to the main Performance Setting window with the recommended value already entered.

You would finish all your Advise window processing and then select **Apply** to have the recommended values actually set.

The advise text recommends manual adjustment of pool sizes and activity levels for Web application environments.

We selected **Set value** for both the Performance Adjustment (i5/OS system value QPFRADJ) recommended value and the recommended 65535 value for the TCP/IP send buffer — an i5/OS Configure TCP/IP Attributes parameter.

Figure 9-56 on page 353 shows our two changed values.

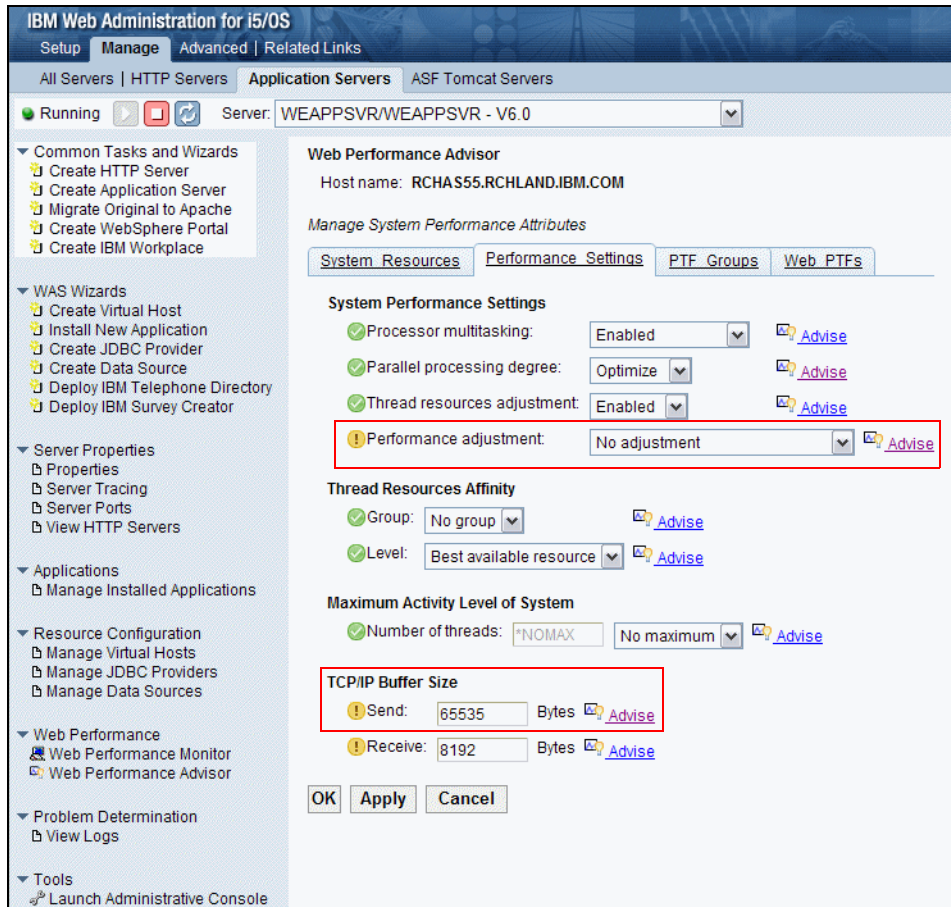

Figure 9-56 Changed Performance Settings - example

You must click **Apply** to have the changes put into effect.

The Web Environment section of the Web Performance Advisor (Figure 9-50 on page 347) allows you to select either your Web application server or your HTTP server.

This option is another place where Web Performance Advisor demonstrates significant advantages over the administrative console interfaces of the Web application servers you are using — for finding individual performance-related parameters and assisting you in evaluating and optionally changing a value for each of the parameters.

Instead of you wandering around several levels of windows to find the important performance parameters, the advisor retrieves them and places them on advisor windows in one place where you can quickly view, review the advise information, and, depending on the parameter, change them. Advise information is provided for each parameter that is presented to you.

Using the window shown in Figure 9-50 on page 347, we first select **WEHTTSPVR** and then clicked **Manage attributes** to get the window shown in Figure 9-57 on page 354.

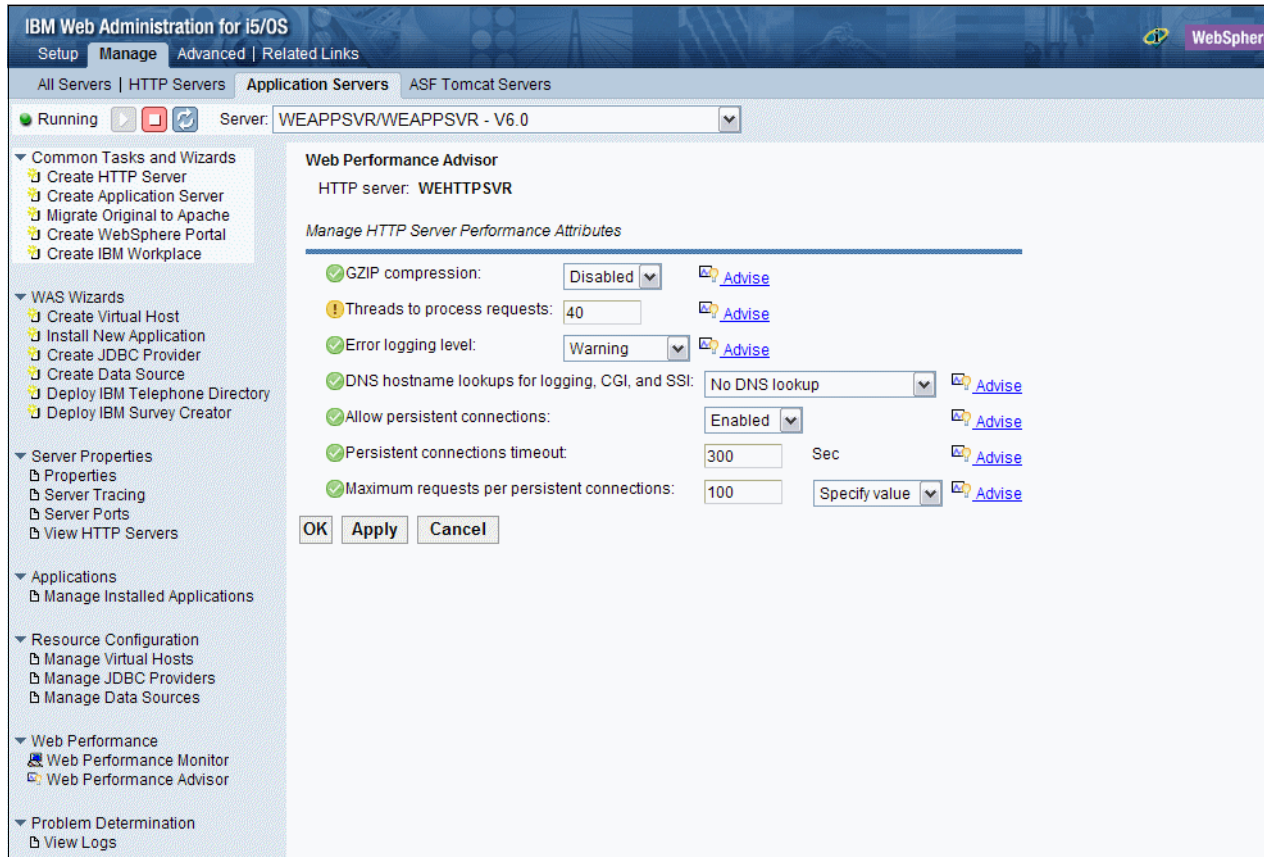

Figure 9-57 Web advisor - HTTP Server Web environment settings

Reviewing the Advise link for each parameter can provide useful information for those who are new to HTTP serving performance considerations and also provide helpful reminders to those of you who are familiar with, but not experts on, HTTP performance considerations.

In our example, we only show the Advise window (in Figure 9-58 on page 355) for the Threads to process requests parameter highlighted by the exclamation point icon (!).

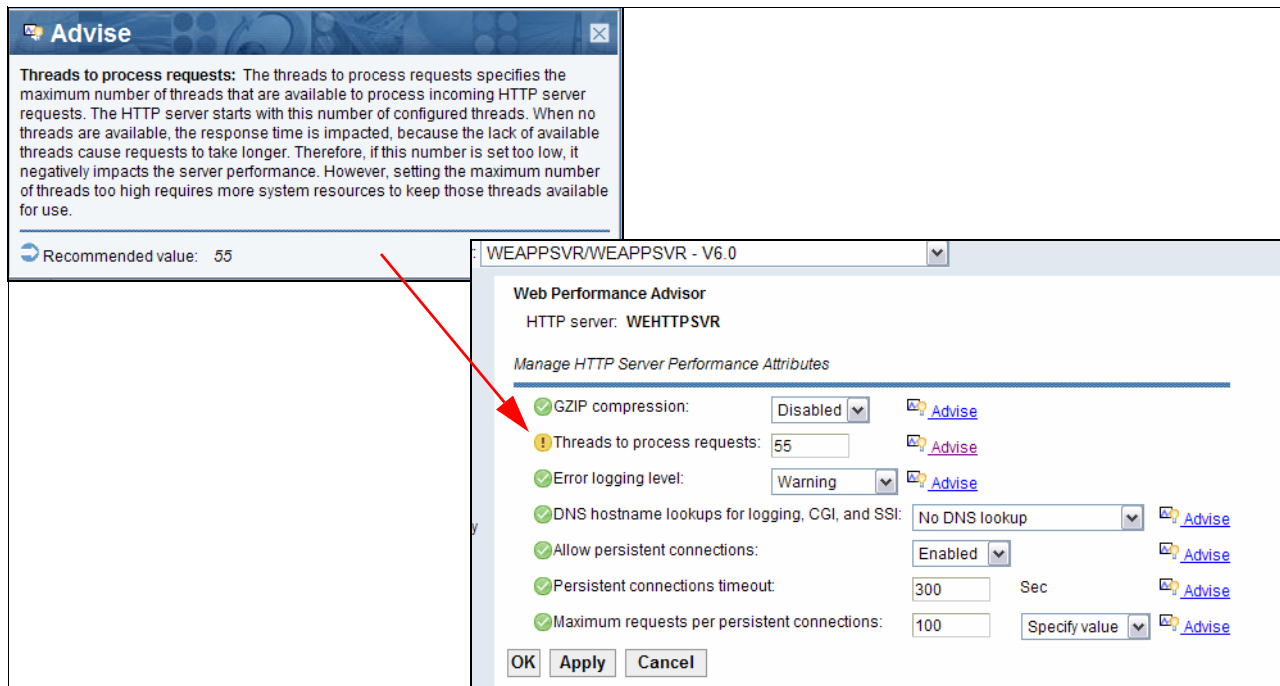

Figure 9-58 Advise window for threads to process

We click **Set value** in the lower right of the Advise window to change to the recommended 55 value, as shown of Figure 9-58. Then we click **Apply**.

Now, using the window shown in Figure 9-50 on page 347, we select **WEAPPSVR**, and then we click **Manage attributes**.

The four categories of Web Environment parameters for the Web application server are:

- ▶ Java Virtual Machine (JVM) parameters
- ▶ Application server resources
- ▶ Java Database Connectivity (JDBC) parameters
- ▶ Additional Web application server settings

Refer to the Web Environment area of the window shown in Figure 9-50 on page 347. Click **Manage attributes** to initially open the JVM Settings tab window, as shown in Figure 9-59 on page 356.

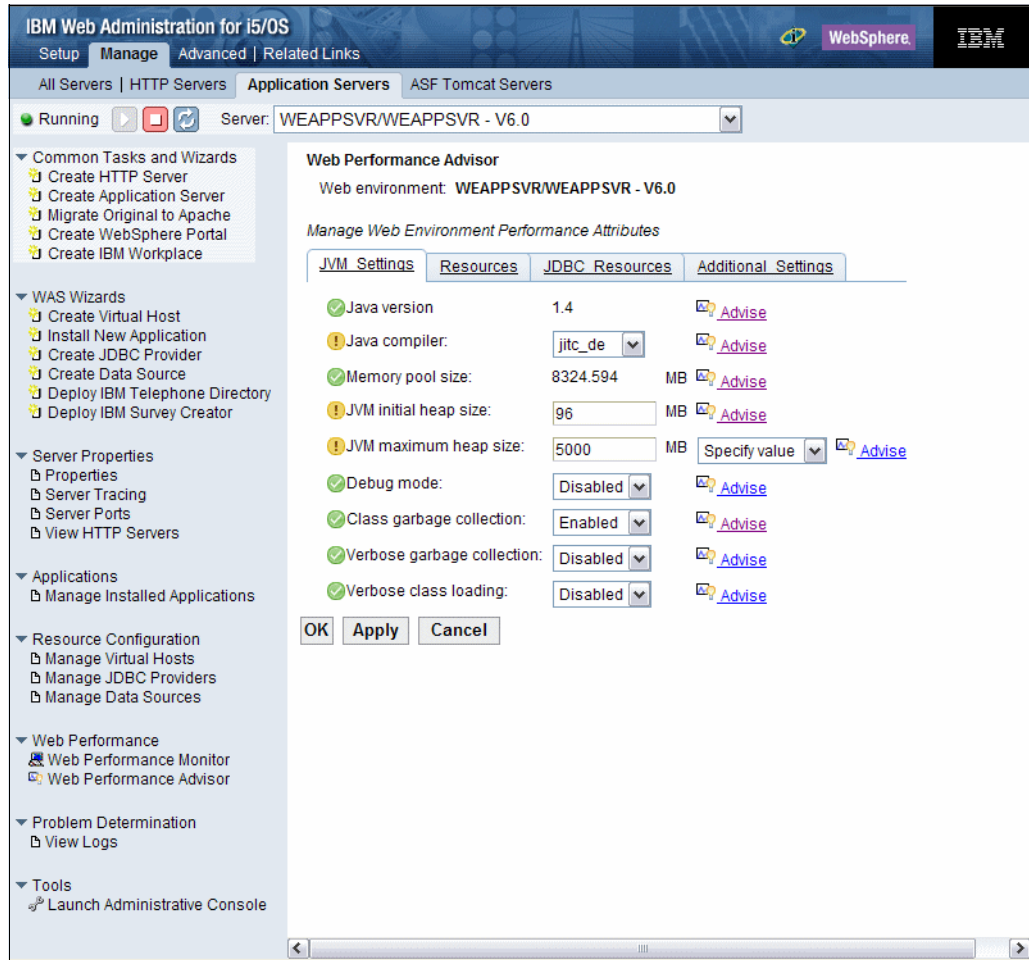

Figure 9-59 Web environment JVM settings

Note the important performance parameters in this JVM settings category. We select Advise for the three parameters with the exclamation point:

- ▶ Java version (initial setting jitc\_de - direct execution)
- ▶ JVM initial heap size (initial size 96)
- ▶ JVM maximum heap size (initial size 5000)

Figure 9-60 shows the Advise windows for each of these settings.

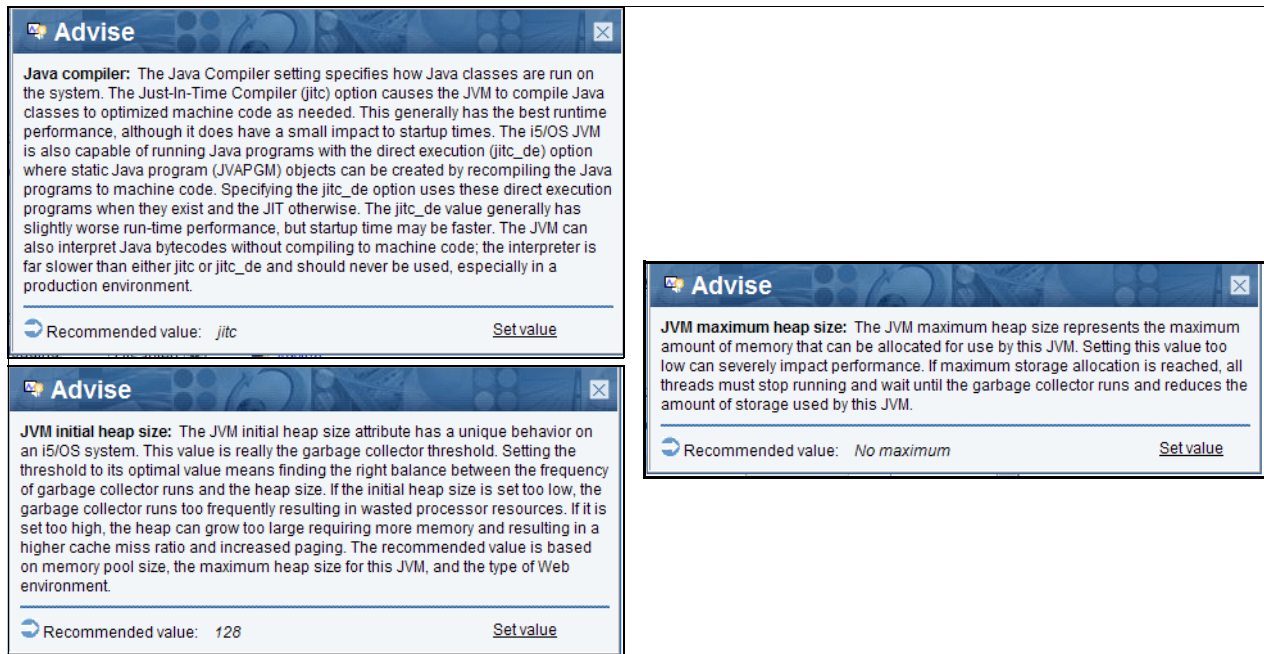

Figure 9-60 JVM settings advise examples

You can review the text in all of the Advise windows shown.

One of the important WebSphere Application Server for i5/OS parameters is the Java compiler parameter. The Direct Execution setting, `jtc_de`, was originally the fastest performing compiler option under i5/OS. However, in the last few years the standardization of Java compilers across IBM has resulted in the Just In Time (JIT) setting (`jtc`) being the best performing choice under i5/OS.

We decided to make some of the advised changes. Figure 9-61 on page 358 shows all of the changes we selected to make, before we applied them.

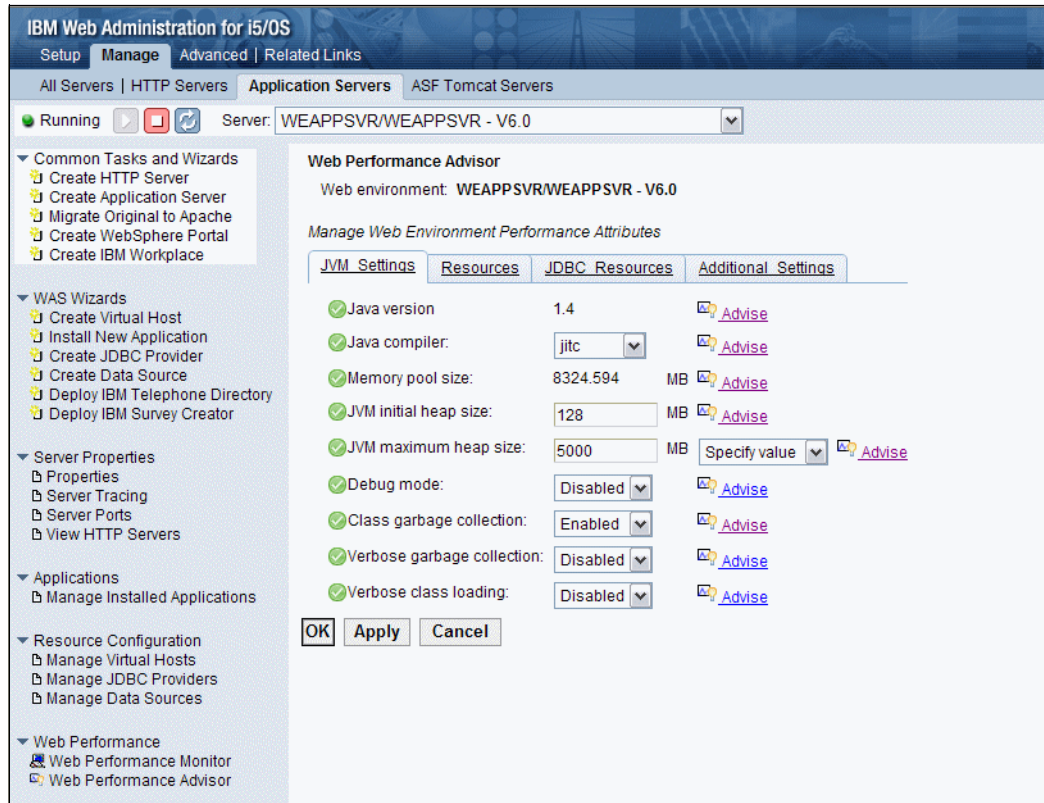

Figure 9-61 JVM settings after completing all changes to be applied

We clicked **Apply**. After a few seconds the apply finished.

We also selected the **Resources** tab, **JDBC Resources** tab, and then the **Additional Settings** tab. In this book, however, we show only the windows that represent these settings. We do not show additional advise function examples. The information in these tabs gets into WebSphere Application Server details that are beyond the scope of this book.

The content in this chapter is sufficient to encourage you to take advantage of the Web Performance Advisor functions that were initially delivered during November 2006. Combined with the other *Web enablement* enhancements that we describe in this chapter, i5/OS offers a much easier way to get started using WebSphere Application Server-based environments than you having to create your own applications.

Click the **Resources** tab to get the window shown in Figure 9-62.

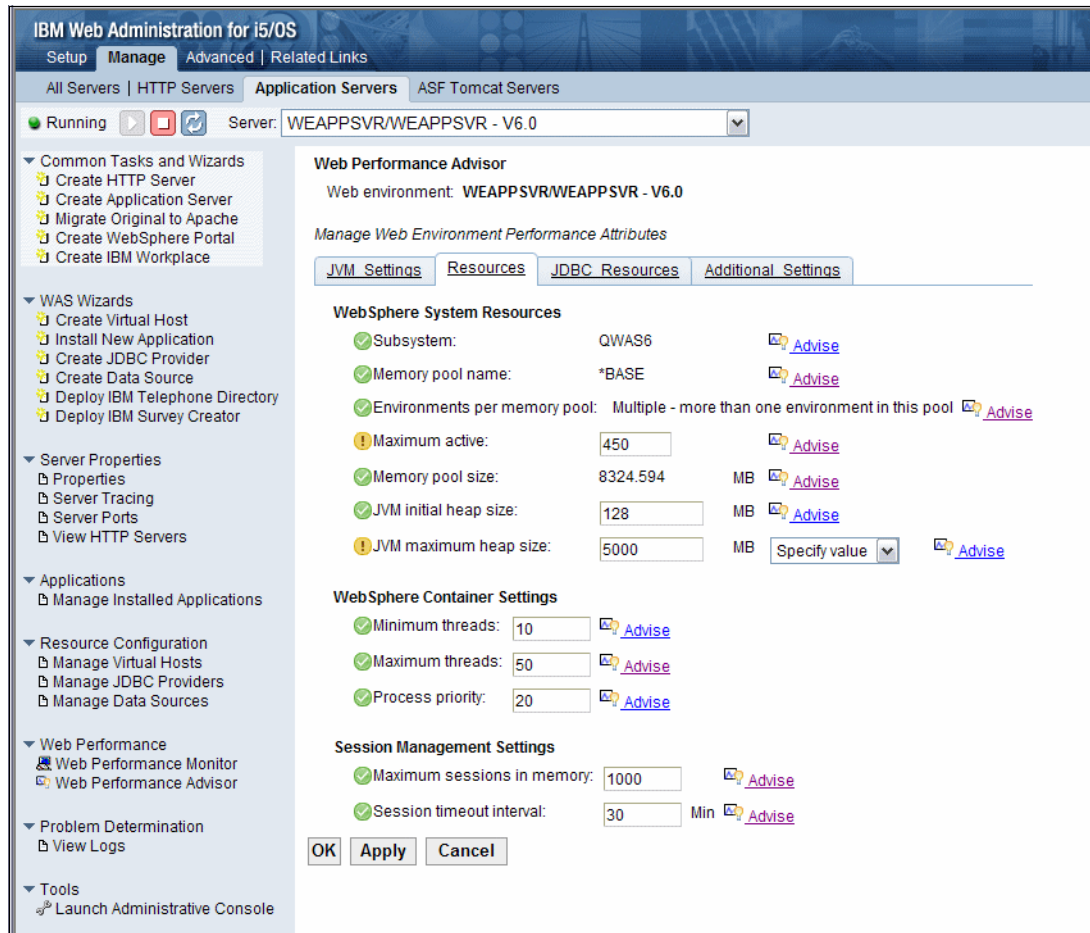

Figure 9-62 Advisor - Web Environment Resource

The resource settings cover i5/OS-specific settings for the default subsystem in which WebSphere Application Server for i5/OS V6.0 runs Java heap size parameters (also covered under JVM settings), and several WebSphere specific settings.

Click the **JDBC Resource** tab to get the window shown in Figure 9-63.

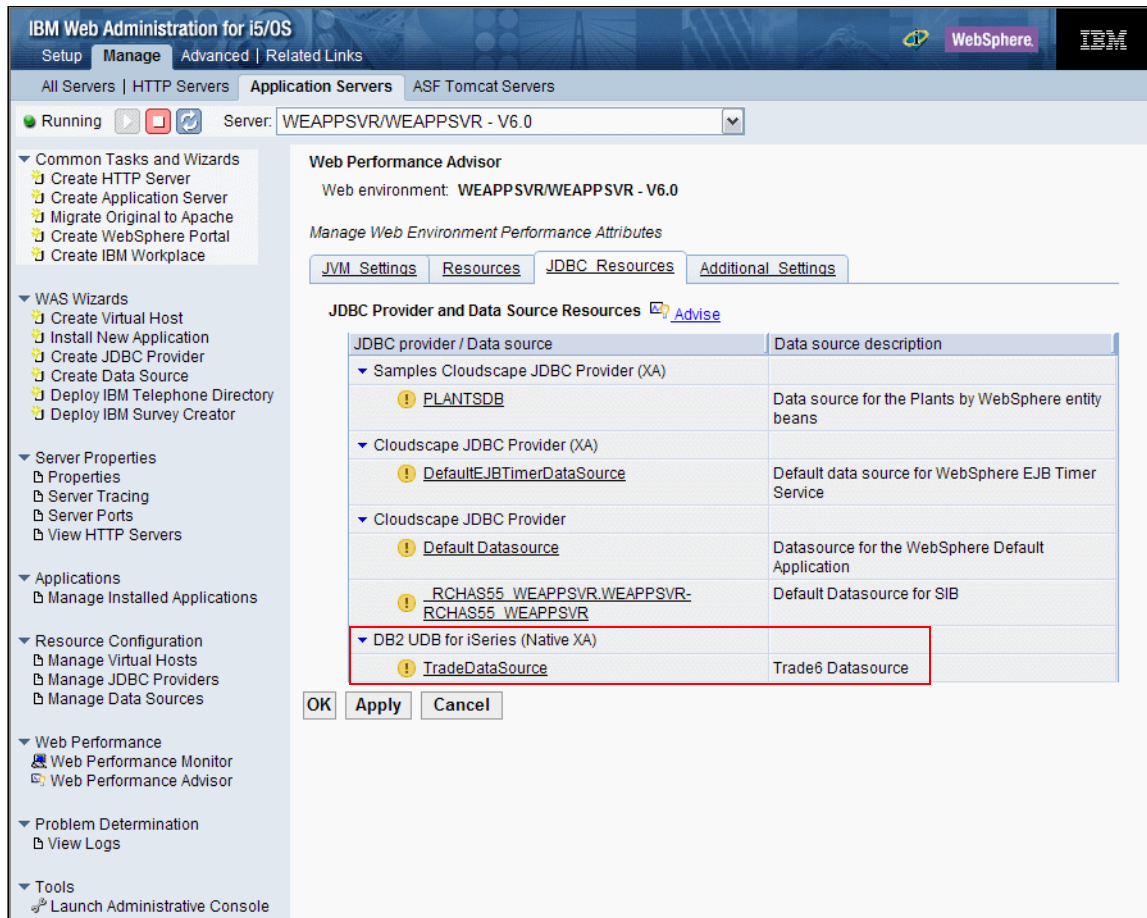

Figure 9-63 Advisor - Web environment - JDBC Resources

A JDBC provider tells the application server what type of access method to use when it needs to access information from a database. A data source that is contained within a JDBC provider links to the actual database. Under i5/OS, there are two commonly used i5/OS jobs that you can use under these interfaces, regardless of the names that you see for the JDBC provider or data source. In the actual definition of the JDBC provider-data source, you specify one of two:

- ▶ Local - IBM Developer Kit for Java JDBC driver (the Native JDBC driver)
- ▶ Remote - IBM Toolbox Java JDBC driver

Local functions run in one of the database server jobs that are included under i5/OS with the QSQSRVR job name prefix. This interface is unique to i5/OS.

Remote functions run in one of the database server jobs that are included under i5/OS with the QZDASOINIT job name prefix. This interface is common across Java implementations on all operating systems.

The JDBC resources are defined under your WebSphere Application Server profile, in our example WEAPPSVR. Remember that the name itself does not identify which local or remote SQL interface under i5/OS is being used.

For WEAPPSVR, we have several JDBC providers or data sources listed, some of which you may not expect if you are new to WebSphere. It is up to the Web applications to use these

data sources or to go to the appropriate database directly from the application code, for example, in this chapter, neither iSeries Access for Web or the flight400 applications use the WebSphere Application Server JDBC data sources.

However, without getting into details, there are some advantages for the applications that are specifically designed to run under WebSphere Application Server to interface with the appropriate database through the WebSphere Application Server JDBC resources.

In our example application server, WEAPPSVR, you can see JDBC provider/data source resources that include those that are shipped with IBM-provided, but optionally installed, sample applications that come with WebSphere Application Server on most supported operating systems.

Note the TRADE6 data source for the TRADE6 internal IBM application, which we optionally installed into WEAPPSVR.

With this JDBC Resources set of parameters, you can view the Advise window information. A more in-depth discussion of the performance aspects of the Advise window information in this area is beyond the scope of this book.

Last, but not the least, we show a window example of the Additional Settings tab window in Figure 9-64.

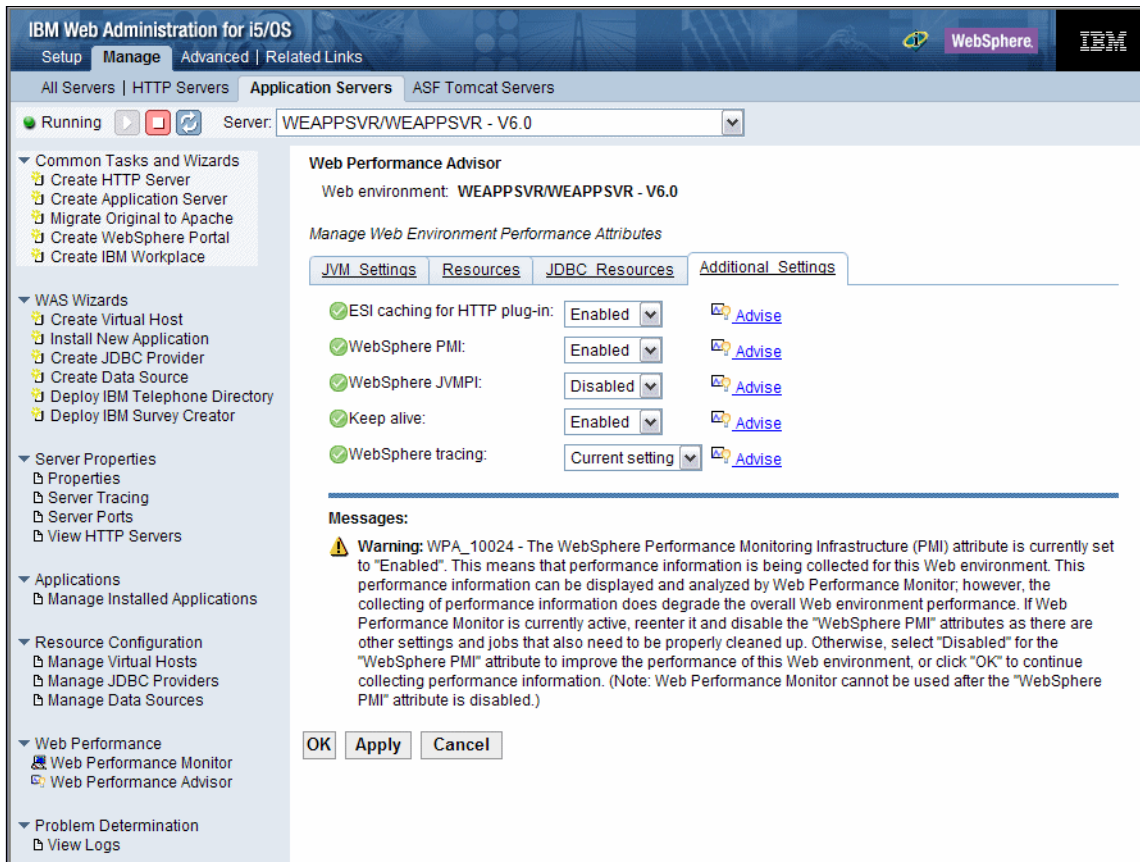

Figure 9-64 Advisor - Additional Settings

The Additional settings window contains miscellaneous performance-related parameters. Note the parameters that are set to enabled and disabled with no exclamation points shown. However, as indicated under Messages, note that the WebSphere Application Server profile

WEAPPSVR does have the WebSphere Performance Monitoring Infrastructure (PMI) enabled to collect performance information.



## Backup and recovery

WebSphere Application Server is only one of the products installed on an i5/OS server. It typically also hosts a Web server, database, and other components that make up a complete Web environment. In this chapter, we describe how to save and restore your complete WebSphere Application Server environment; however, you also need to have a backup strategy for any other products that are running on the i5/OS server that are critical to the Web environment.

In this chapter, we discuss the following topics:

- ▶ Backup procedures for WebSphere Application Server
- ▶ Frequency of backups
- ▶ Recovery procedures for WebSphere Application Server

## 10.1 Understanding your environment

The WebSphere Application Server environment is complex. You need to be sure that you save not only your WebSphere Application Server configuration but also databases that applications use, security settings, and so on.

In the following sections, we show you how to save each component of a typical WebSphere Application Server environment. We assume, in this chapter, that you have familiarity with the common procedures to save and restore in i5/OS.

To understand the procedures of backup and restore, and to define a good backup policy see:

- ▶ For V5R3:

<http://publib.boulder.ibm.com/InfoCenter/iserries/v5r3/index.jsp?topic=/rzaiu/rzaiuicbackup.htm>

- ▶ For V5R4

<http://publib.boulder.ibm.com/infocenter/iserries/v5r4/index.jsp?topic=/rzahg/rzahgbackup.htm>

## 10.2 Locating your files

The new feature that allows you to choose the location of both the product data and user data in WebSphere Application Server V6.1 makes save and restore operations different compared to previous releases. In earlier versions, you always knew the location of the data to be backed up. With Version 6.1, the first thing you have to do is to locate where your data is stored.

In 3.7.3, “Verifying the installation directories” on page 57 we introduced you to the queryWASinstalls script. This script shows you the location of your different WebSphere Application Server directories and libraries.

In Figure 10-1 on page 365, you see an example where the WebSphere Application Server installation is not in the default location.

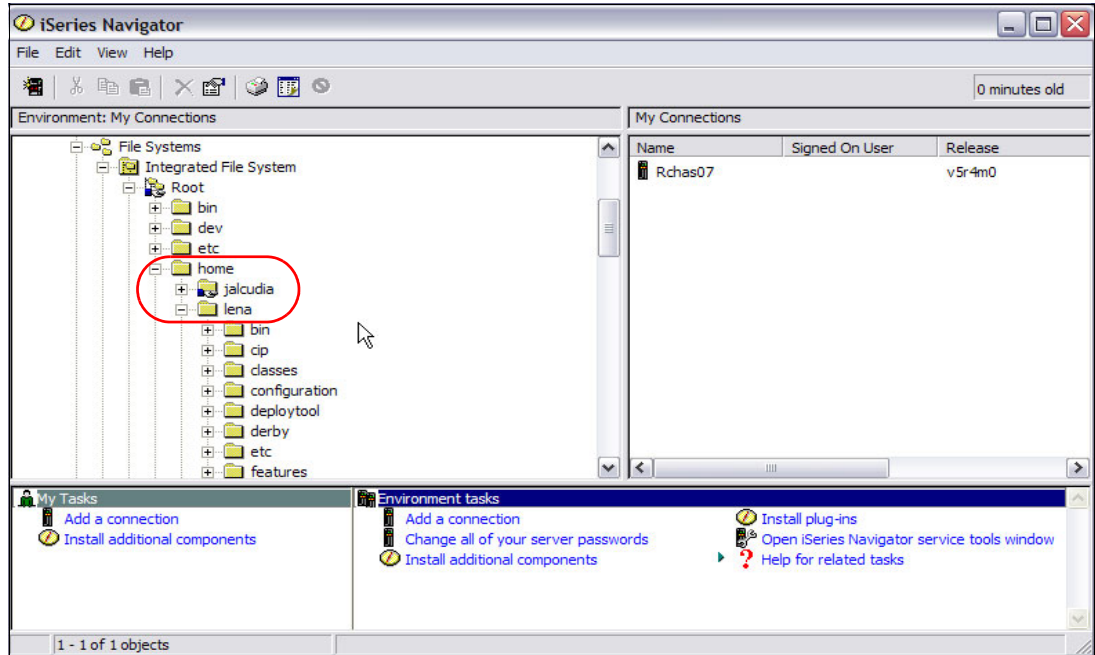

Figure 10-1 WebSphere Application Server installation in /home/lena

The queryWASinstalls script shows you the location of the following components of each installation:

- ▶ Product Directory <install\_root>
- ▶ User Data <profiles>
- ▶ Install library <install\_library>

Figure 10-2 on page 366 shows you an example of the output from the queryWASinstalls script.

```
QSH Command Entry

Default Profile Location:/QIBM/UserData/WebSphere/AppServer/V61/Base1
-----
Offering ID:          UPDI
Version:              6.1.0.0
Installation Location: /QIBM/ProdData/WebSphere/UpdateInstaller/V61/UPDI
-----
Offering ID:          BASE
Version:              6.1.0.0
Installation Location: /home/lena
Installation Library:  QWAS61A
Default Profile Location:/home/lena
-----
Total: 4 products installed.
$

====>

F3=Exit  F6=Print  F9=Retrieve  F12=Disconnect
F13=Clear F17=Top   F18=Bottom  F21=CL command entry
```

Figure 10-2 queryWASinstalls output

## 10.3 Saving WebSphere Application Server

The objects of WebSphere Application Server V6.1 are distributed between the QSYS.LIB and the IFS. In this section, we show you how to save these different parts of a WebSphere Application Server installation.

**Restriction:** The SAVLICPGM and RSTLICPGM commands are not supported in WebSphere Application Server V6.1.

### 10.3.1 QSYS.LIB objects

In this section, we show you what objects in the QSYS.LIB library that your WebSphere Application Server uses.

#### Product Libraries

Each installation of WebSphere Application Server in your system shares a library called *QWAS61*. In addition, each installation uses a private *installation library* for applying WebSphere Application Server fixes. See 1.2.1, “Installation enhancements” on page 10 for more information about installation libraries.

In your backup plan, you *must* save the shared QWAS61 library. Also you *must* save the installation library for each installation, if you have multiple installations. See 10.2, “Locating your files” on page 364 to see where your installation libraries can be found.

## User profiles

WebSphere Application Server uses the following special user profiles:

- ▶ QEJB: This is shipped as part of the i5/OS operating system. This user profile is only used when accessing validation list objects, which are used for storing the encoded passwords that are used with WebSphere Application Server.
- ▶ QEJBSVR: This user profile used to be created when you installed WebSphere Application Server, but in i5/OS V5R4 this user is shipped as part of the operating system. This profile is the default profile under which all application servers run. It owns directories and files used by WebSphere Application Server. If you specified another profile under which you run your application server, see the documentation at:

[http://publib.boulder.ibm.com/InfoCenter/wsdoc400/topic/com.ibm.websphere.iseries.doc/info/ae/ae/tsec\\_isprfchg.html](http://publib.boulder.ibm.com/InfoCenter/wsdoc400/topic/com.ibm.websphere.iseries.doc/info/ae/ae/tsec_isprfchg.html)

Consider saving the user profiles as a part of your WebSphere Application Server backup and recovery strategy. There are several cases to consider:

- ▶ When you use local i5/OS security, backup your i5/OS user profiles, using OS/400 save procedures for user profiles. For more information, see the Backup and Recovery Guide in the Information Center:

For V5R3M0:

<http://publib.boulder.ibm.com/InfoCenter/series/v5r3/topic/rzaiu/rzaiuicbackup.htm>

For V5R4M0:

<http://publib.boulder.ibm.com/infocenter/series/v5r4/index.jsp?topic=/rzahg/rzahgbackup.htm>

- ▶ When you use LDAP, see *Save and Restore Directory Server information* at:  
<http://publib.boulder.ibm.com/InfoCenter/series/v5r3/index.jsp?topic=/rzahy/rzahybup-rf.htm>
- ▶ If you use Lotus Domino for LDAP, backup your Domino server as usual. See the IBM Redbooks publication *Domino 6 for iSeries Best Practices Guide*, SG24-6937 or, depending on your version of Domino.

## EJB persistence data

Enterprise beans often use a database for back-end persistence. Container-managed entity beans always use a database for back-end persistence. If you are using enterprise beans, back them up the same way as any of your business data.

The collection for container-managed entity beans persistence is determined by either the schema name that is specified during deployment or the schema that is specified on the data source that is associated with the enterprise bean. Any persistent store used by session and bean-managed beans is defined by the bean implementation. For database tables, you can choose to save the entire collection or an individual table, as shown with the following examples:

- ▶ This command saves the entire collection:  
SAVLIB LIB(EJB) DEV(\*SAVF) SAVF(WSALIB/WSASAVF)
- ▶ This command saves one table from the application database:  
SAVOBJ OBJ(MYBEANTBL) LIB(EJB) DEV(\*SAVF) OBJTYPE(\*FILE) SAVF(WSALIB/WSASAVF)

It may be possible to save database objects while WebSphere Application Server is active, if the save operation can obtain a snapshot of the data store. You may have to shut down your

application server if a snapshot cannot be obtained. This would occur if there are requests that obtain locks or that have open transactions against the database being saved.

For more information, see the Backup and Recovery Guide in the Information Center:

For V5R3M0:

<http://publib.boulder.ibm.com/InfoCenter/iseriess/v5r3/topic/rzaiu/rzaiuicbackup.htm>

For V5R4M0:

<http://publib.boulder.ibm.com/InfoCenter/iseriess/v5r4/topic/rzaiu/rzaiuicbackup.htm>

## Web server configuration

The following information applies to IBM HTTP Server. If you are using Lotus Domino HTTP Server, see the IBM Redbooks publication *Domino 6 for iSeries Best Practices Guide*, SG24-6937 or *Implementing IBM Lotus Domino 7 for i5/OS*, SG24-7311, depending on your version of Domino.

Changes to the HTTP configuration are often made to enable WebSphere Application Server to service requests for servlets and JavaServer Pages (JSP) files and to enable WebSphere Application Server security. Consider saving your HTTP configuration as a part of your WebSphere Application Server backup and recovery strategy. The IBM HTTP Server configurations are stored as members of the QATMHTTTPC file in the QUSRSYS library. HTTP server instances are members of the QATMHINSTC file in the QUSRSYS library. The following example commands back up these files:

```
SAVOBJ OBJ(QUSRSYS/QATMHTTTPC)
SAVOBJ OBJ(QUSRSYS/QATMHINSTC)
```

## Backing up key files

The key files contain certificates that are used by the security infrastructure for WebSphere Application Server. These certificates are also used for HTTPS transport between servers. Save all of the files in the `<install_root>/etc` directory. Key files are contained in the `<install_root>/etc` directory, but administrators might create and store these files in other directories.

## Validation lists

Passwords are stored as encrypted data in validation list objects when the i5/OS password encoding algorithm is used.

The default validation list is `/QSYS.LIB/QUSRSYS.LIB/EJSADMIN.VLDL`, but you can change it in the administrative console by specifying it as a system property for the application server.

Use the **SAVOBJ** command for the save procedure, for example, performing the follow command, you can save the validation lists:

```
SAVOBJ OBJ(EJSADMIN) LIB(QUSRSYS) DEV(*SAVF) SAVF(WSALIB/WSASAVF)
```

Use the **RSTOBJ** command for the restore procedure, for example, performing the follow command, you can restore the validation lists from your backup:

```
RSTOBJ OBJ(EJSADMIN) SAVLIB(QUSRSYS) DEV(*SAVF) OBJTYPE(*VLDL)
SAVF(WSALIB/WSASAVF)
```

## 10.3.2 IFS files

In this section, we cover the resources that define your WebSphere Application Server environment, which includes configuration data and application-related information.

### Saving product data

Use the i5/OS SAV command to backup the root install directory of your WebSphere Application Server V6.1 installation, for example, to backup the install directory for the default location to a tape device, use the command:

```
SAV DEV('/QSYS.LIB/TAP01.DEVD')
OBJ((' /QIBM/ProdData/WebSphere/AppServer/V61/Base/*'))
```

Save the /QIBM/WAS directory, where some utilities, such as queryWASinstalls, are stored:

```
SAV DEV('/QSYS.LIB/TAP01.DEVD') OBJ((' /QIBM/WAS/*'))
```

This directory is used by all installations on the system/partition. Also, there is the /QIBM/WAS/.ibm/.nif/.nifregistry file that stores information about the locations of all WebSphere installations. See Figure 10-3 for a sample of the .nifregistry file contents.

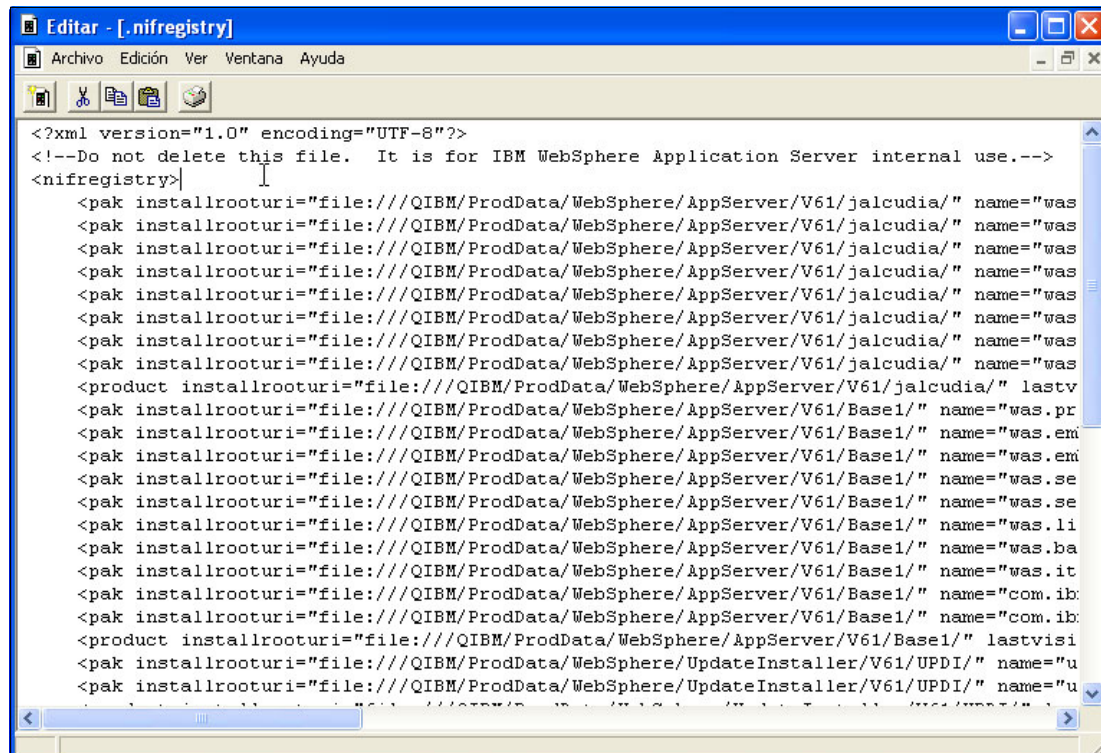

Figure 10-3 A view of the nifregistry file

### Saving user data

By saving the entire **profiles** directory, you can save all user data that exists in the integrated file system (IFS). This directory and its subdirectories contain the following data:

- ▶ Server configuration files (administrative configuration and HTTP configuration)
- ▶ Security configuration (security property files and key files)
- ▶ Enterprise Applications (HTML, Servlets, JSP files, Enterprise Archive files, and so on)
- ▶ Other resources (log files, temporary files, and so on)

To save the profiles directory, use the SAV command, for example, to save the user data directory for a WebSphere Application Server installation in the default location use:

```
SAV DEV('QSYS.LIB/TAP01.DEVD')
OBJ(('QIBM/UserData/WebSphere/AppServer/V61/Base/profiles/*'))
```

**Important:** You must save both the ProdData and UserData directories for each of the different installations you want to save.

### Saving selective user data

In the previous section, we showed you how to backup the entire profiles directory. Alternatively, you might decide to back up only a specific part of your user data. In this section, we show how to:

- ▶ Back up the configuration data
- ▶ Back up the installed application
- ▶ Export the installed applications to the EAR files

### Backing up a profile's configuration data

WebSphere Application Server stores its administrative configuration as XML files. Use the **backupConfig** command in your Product Install directory to backup configuration files. The resulting save file is stored as a zip file. You can specify the name of the backup file that you want to use, for example (see Figure 10-4):

```
cd /QIBM/ProdData/WebSphere/AppServer/V61/Base/bin
backupConfig /home/ALEKN/remotewasProfile.zip -profileName remotewas
```

```
QSH Command Entry

$
> backupConfig /home/ALEKN/remotewasProfile.zip -profileName remotewas
ADMU0116I: Tool information is being logged in file
/QIBM/UserData/WebSphere/AppServer/V61/Base/profiles/remotewas/logs/backupConfig.log
ADMU0128I: Starting tool with the remotewas profile
ADMU5001I: Backing up config directory
/QIBM/UserData/WebSphere/AppServer/V61/Base/profiles/remotewas/config
to file /home/ALEKN/remotewasProfile.zip
ADMU0505I: Servers found in configuration:
ADMU0506I: Server name: remotewas
ADMU2010I: Stopping all server processes for node RCHAS10_remotewas
ADMU0510I: Server remotewas is now STOPPED

.....
ADMU5002I: 275 files successfully backed up
$

===>

F3=Exit F6=Print F9=Retrieve F12=Disconnect
F13=Clear F17=Top F18=Bottom F21=CL command entry
```

Figure 10-4 backupConfig output

**Important:** By default, all servers on the node stop before the backup is made, so partially-synchronized information is not backed up on all nodes.

### ***Saving installed applications***

You should consider JavaServer Pages (JSP) source and generated servlet classes, Hypertext Transfer Protocol (HTTP) configuration, and administrative configuration for backup when you use JSP files.

Application code and configuration, such as bindings, are located by default in the `<profile_root>/installedApps` directory.

**Note:** If you saved your profiles directory, you already saved the applications.

Use the SAV command to back up all of the applications in your WebSphere Application Server profile, remotewas in our example. For a default installation the command is:

```
SAV DEV('/QSYS.LIB/TAP01.DEVD')
OBJ((' /QIBM/UserData/WebSphere/AppServer/V61/Base/profiles/remotewas/installedApps
/*'))
```

To back up only one application, DefaultApplication in our example, you can choose to save only the directory that contains that application, for example:

```
SAV DEV('/QSYS.LIB/TAP01.DEVD')
OBJ((' /QIBM/UserData/WebSphere/AppServer/V61/Base/profiles/remotewas/installedApps
/RCHAS10_remotewas/DefaultApplication.ear'))
```

In the above example, RCHAS10\_remotewas is the name of the node.

**Tip:** When JSP files are run, a servlet class is generated, compiled, and then run. You can save the generated files by backing up the:

`<profile_root>/temp/<nodename>/application_server/enterprise_app/web_module` directory.

Example:

```
/QIBM/UserData/WebSphere/AppServer/V61/Base/profiles/temp/RCHAS07/application_s
erver/enterprise_app/web_module
```

### ***Exporting installed applications to the EAR files***

Another option that you can use to back up your application files is to export your enterprise application already installed. You can back up the EAR file by exporting it onto a tape, or you can keep this file in an IFS directory. You can perform the exporting process while the enterprise application is still running. To export EAR files, perform the following steps:

1. Start the WebSphere Administrative Console, and point your browser to:

```
http://<host_name>:<port>/ibm/console
```

Here, `<host_name>` is your System i host name and `<port>` is the administration console port (see 4.2.6, “Accessing the WebSphere Administrative Console” on page 121 for more information).

2. Enter your WebSphere user ID in the User ID field, and click **Log in**.
3. In the next window, expand **Applications**, and click **Enterprise Applications**.

4. Select the check box next to the enterprise application that you want to export, and click **Export** (see Figure 10-5).

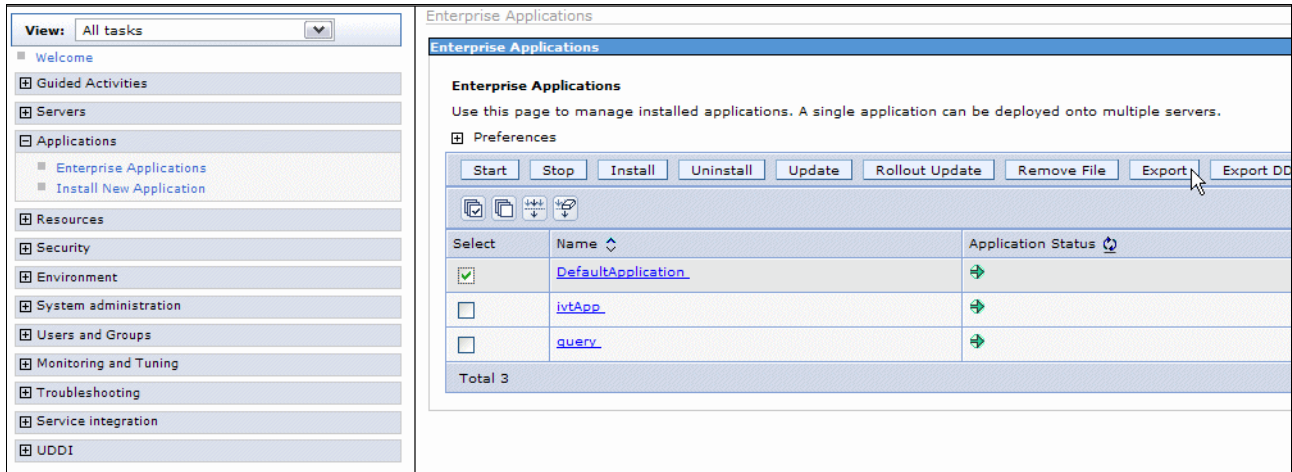

Figure 10-5 Invoking the Export wizard

5. In the next panel, click the enterprise application link.
6. Select **Save** in the dialog (see Figure 10-6). In the next pop-up window, select the location for the exported EAR file.

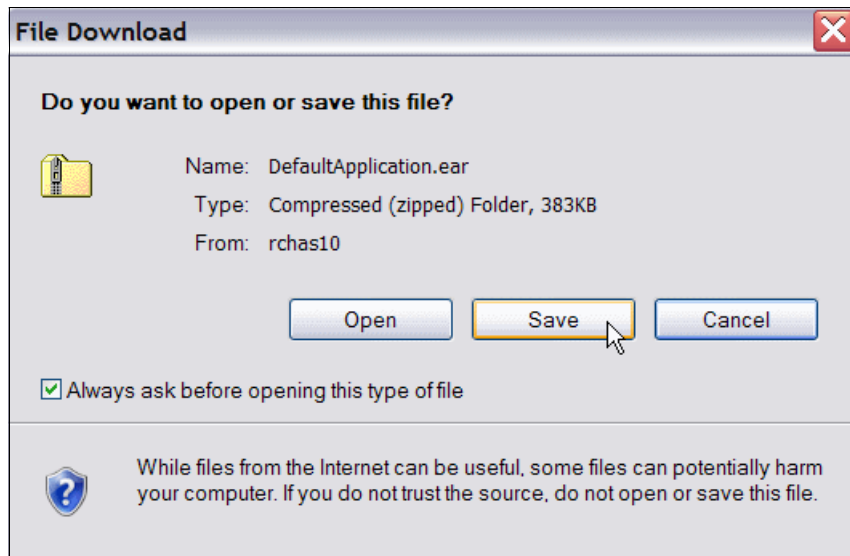

Figure 10-6 File Download dialog

You can save the EAR file to the i5/OS server using a mapped network drive or iSeries Access for Windows, for further backup to tape.

## 10.4 Backing up WebSphere Application Server Network Deployment

To back up your WebSphere Application Server Network Deployment environment, use the same procedure that you use for standalone Base edition installations.

In a Network Deployment environment, if one of your servers becomes unavailable for any reason, the fail-over task passes the load from this server to the other servers and marks the failed server as unavailable. If you recover your server from the backup and connect it again to the cell, it is added again to the available servers pool by the Deployment Manager.

The default paths for the shared Product directory and profile directory in WebSphere Application Server Network Deployment are:

```
/QIBM/ProdData/WebSphere/AppServer/V61/ND/  
/QIBM/UserData/WebSphere/AppServer/V61/ND/profiles/
```

## 10.5 Saving additional licensed products

WebSphere Application Server on i5/OS uses some additional licensed products. Consider these products when you define your backup plan. While you are backing up these products, stop all WebSphere jobs.

The following list contains the products that you must consider in your backup plan:

- ▶ Operating System/400® (5722SS1)
- ▶ IBM Developer Kit for Java (5722JV1)
- ▶ OS/400 Qshell (5722SS1 option 30)
- ▶ HTTP Server:
  - IBM HTTP Server for iSeries (5722DG1)
  - Lotus Domino 6.5 for iSeries (5733L65)
  - Lotus Domino 7.0 for i5/OS (5733L70)

For all of these products, use the SAVLICPGM command. Figure 10-7 on page 374 shows the command that saves both libraries and IFS directories that are associated with the HTTP server licensed product.

```

                                Save Licensed Program (SAVLICPGM)

Type choices, press Enter.

Product . . . . . 5722DG1      Character value
Device . . . . . TAP01        Name, *SAVF
      + for more values
Optional part to be saved . . . *BASE      *BASE, 1, 2, 3, 4, 5, 6, 7...
Release . . . . . *ONLY        Character value, *ONLY
Language for licensed program . *PRIMARY   Character value, *PRIMARY...
Object type . . . . . *ALL      *ALL, *PGM, *LNG
Check signature . . . . . *SIGNED *SIGNED, *ALL, *NONE

                                                                    Bottom
F3=Exit  F4=Prompt  F5=Refresh  F12=Cancel  F13=How to use this display
F24=More keys

```

Figure 10-7 SAVLICPGM example

Perform the restore procedure, if required, using the **RSTLICPGM** command (see Figure 10-8 on page 375). You must be sure that all licensed products are restored before you try to use the WebSphere Application Server product.

```

Restore Licensed Program (RSTLICPGM)

Type choices, press Enter.

Product . . . . . 5722DG1      Character value
Device . . . . . TAP01        Name, *SAVF
      + for more values
Optional part to be restored . . *BASE      *BASE, 1, 2, 3, 4, 5, 6, 7...
Type of object to be restored . *ALL       *ALL, *PGM, *LNG
Language for licensed program . *PRIMARY   Character value, *PRIMARY...
Output . . . . . *NONE       *NONE, *PRINT
Release . . . . . *FIRST     Character value, *FIRST
Replace release . . . . . *ONLY Character value, *ONLY, *NO

Bottom
F3=Exit  F4=Prompt  F5=Refresh  F10=Additional parameters  F12=Cancel
F13=How to use this display  F24=More keys

```

Figure 10-8 RSTLICPGM example

## 10.6 Saving your database

Arguably, the most important part of your environment is the data. After all, WebSphere Application Server is essentially an interface to your company data using the applications that are deployed to the application servers.

In a standalone configuration, your database is stored on the same machine that your WebSphere Application Server instance runs. However this is just one of the multiple configurations that are possible in a WebSphere Application Server environment.

You can have your database on another partition, another i5/OS server, or another database that allows access from Java.

If you have your data stored in DB2 UDB for i5/OS, refer to the Information Center for information about backing up this data:

<http://publib.boulder.ibm.com/InfoCenter/iserics/v5r4/index.jsp?topic=/rzaj1/rzaj1/overview.htm>

## 10.7 Frequency of backups

How often you back up resources depends largely on when or how often you expect them to change. Use the categorizations in this section to determine how you should fit WebSphere Application Server resources into your backup plan.

### 10.7.1 WebSphere Application Server licensed products

In this category, we cover the licensed products of your WebSphere Application Server and the related products. You should save these products after you apply any PTFs. Items in this group are:

- ▶ Licensed products of the WebSphere Application Server
- ▶ Other related products

### 10.7.2 WebSphere Application Server environment configuration

In this category, we cover the resources that define your WebSphere Application Server operating environment. After you perform the initial backup, this information should change very infrequently. You might backup this information only when you change these settings and not include these resources in regularly scheduled backups. Items in this group are:

- ▶ The administrative configuration
- ▶ HTTP configuration
- ▶ Servlet configuration files
- ▶ Security properties files

### 10.7.3 WebSphere Application Server applications

In this category, we cover the applications that you run using WebSphere Application Server. You should back these up the same way that you back up other applications on your system. You could backup these resources every time you add or change an application or include resources in a regularly scheduled backup. Items in this group are:

- ▶ Servlet source and class files
- ▶ JSP source and generated class files
- ▶ Deployed enterprise bean jar files

### 10.7.4 WebSphere Application Server application data

In this category, we cover the data stores that your WebSphere Application Server applications use. Unless your applications serve only static information, these resources are usually quite dynamic. You should back these up the same way you back up other business data on your system. These resources are suited for inclusion in a regularly scheduled backup. Items in this group are:

- ▶ Servlet user profile data
- ▶ Enterprise bean database data
- ▶ Database files accessed by your applications

## 10.8 Recovery from a failure

The recovery procedures depend on the type of failure. We describe the general steps that are needed to recover your WebSphere configuration, assuming that you already recovered the microcode and operating system. If you need additional information about recovering i5/OS, refer to *Backup and Recovery*, SC41-5304.

## 10.8.1 WebSphere Application Server licensed product

To recover WebSphere Application Server, you have to restore both product libraries and IFS files, for example, to recover an installation to the default location:

1. Restore **shared library**:

```
RSTLIB SAVLIB(QWAS61) DEV(TAP01)
```

**Tip:** If you are restoring a single WebSphere Application Server installation but there are other working installations on the system, you do not need to restore this library because the other installations would not be working if the shared library was corrupt.

2. Restore **Install library** (you may have more than one library to restore):

```
RSTLIB SAVLIB(QWAS61A) DEV(TAP01)
```

3. Restore **Install directory**:

```
RST DEV('/QSYS.LIB/TAP01.DEVD')  
OBJ(('QIBM/ProdData/WebSphere/AppServer/V61/Base/*'))
```

4. Restore **/QIBM/WAS** directory:

```
RST DEV('/QSYS.LIB/TAP01.DEVD') OBJ(('QIBM/WAS/*'))
```

**Tip:** If you are restoring a single WebSphere Application Server installation but there are other working installations on the system, you only have to edit or restore the `.nifregistry` file to add the information for the application server that is being restored.

If any of these backups are unavailable, you must install WebSphere Application Server from the distribution media, and you also must install all licensed products that are required by WebSphere Application Server and all PTFs. Refer to Chapter 3, “Installing WebSphere Application Server” on page 31 for information about installation.

## 10.8.2 WebSphere Application Server configuration

After you restore WebSphere Application Server licensed product, you can recover your applications, administrative configuration for your application, servlets, Java Server Pages (JSP), HTTP configuration, security, and so on, for example, to restore the profiles directory, use the following command:

```
RST DEV('/QSYS.LIB/TAP01.DEVD')  
OBJ(('QIBM/UserData/WebSphere/AppServer/V61/Base/profiles/*'))
```

## 10.8.3 Restoring authorizations

You must be sure that all restored files are owned by the user profile that is used to run all of the jobs that are related to the WebSphere Application Server instance. By default, the QEJBSVR user profile must be the owner of all instance files, including the install library.

**Tip:** You can use the `chgown` command from Qshell to change the owner for a specific directory including all files in it, for example:

```
chgown -R QEJBSVR  
/QIBM/UserData/WebSphere/AppServer/V61/Base/profiles/default
```

This command makes QEJBSVR the owner for all files inside the default directory.

In addition, you should grant private authority to QTMHHTTP and QNOTES user profiles (if they exist) to certain directories. To grant authority, issue the following commands:

- ▶ CHGAUT OBJ('<profilePath>/config') USER(QTMHHTTP) DTAAUT(\*X)
- ▶ CHGAUT OBJ('<profilePath>/config/cells') USER(QTMHHTTP) DTAAUT(\*X)
- ▶ CHGAUT OBJ('<profilePath>/logs') USER(QTMHHTTP) DTAAUT(\*RWX)
- ▶ CHGAUT OBJ('<profilePath>/etc') USER(QTMHHTTP) DTAAUT(\*RX)
- ▶ CHGAUT OBJ('<profilePath>/etc/plugin-key.kdb') USER(QTMHHTTP) DTAAUT(\*RX)
- ▶ CHGAUT OBJ('<profilePath>/etc/plugin-key.sth') USER(QTMHHTTP) DTAAUT(\*RX)

In the commands, <profilePath> is the path to this profile's directory in the IFS, for example:

```
/QIBM/UserData/WebSphere/AppServer/V61/Base/profiles/default
```

Repeat the same commands for the QNOTES profile.

If you have a Web server definition, you should also issue the following commands:

- ▶ CHGAUT OBJ('<webServerPath>') USER(QTMHHTTP) DTAAUT(\*X)
- ▶ CHGAUT OBJ('<webServerPath>/plugin-cfg.xml') USER(QTMHHTTP) DTAAUT(\*X)

In the commands, <webServerPath> is the path to your Web server definition directory, for example:

```
/QIBM/UserData/WebSphere/AppServer/V61/Base/profiles/default/config/cells/<cellName>/nodes/<nodeName>/servers/<webServerName>
```

Repeat the same commands for the QNOTES profile.

#### 10.8.4 WebSphere Application Server application data

According to the nature of the failure, you must consider how to restore the databases that are associated with your application. The database backup must be a part of your normal backup strategy.



# Running WebSphere Application Server with IBM Technology for Java VM

In V5R4, IBM introduced a new Java Virtual Machine (JVM) on System i platform, IBM Technology for Java VM (aka J9). The new JVM is based on a 32-bit architecture and runs in the PASE environment. Now you can choose between Classic JVM (64-bit) and IBM Technology for Java VM (32-bit).

In this chapter, we describe the usage of the IBM Technology for JVM with WebSphere Application Server on System i platform. The topics that we cover are:

- ▶ 11.2, “System requirements for i5/OS” on page 380
- ▶ 11.3, “Switching between JVMs in WebSphere Application Server 6.1” on page 381
- ▶ 11.3.2, “Enabling an existing WebSphere Application Server profile with IBM Technology for JVM” on page 382
- ▶ 11.3.5, “Determining the JVM in use” on page 389
- ▶ 11.4, “Configuring the WebSphere Application Server JVM” on page 391
- ▶ 11.5, “Monitoring the WebSphere Application Server JVM” on page 393
- ▶ 11.6, “Verbose Garbage Collection and logging” on page 397
- ▶ 11.7, “Additional information” on page 398

## 11.1 Why two JVMs

The Classic JVM scales extraordinarily well as the number of users and the application complexity increases. Today, the Classic JVM does not scale down so well. The Classic JVM has too large footprints for some who do not have large-scale Java applications and WebSphere environments. This is where the new 32-bit JVM fits nicely. Figure 11-1 shows the range of applications for both the Classic JVM and IBM Technology for Java VM.

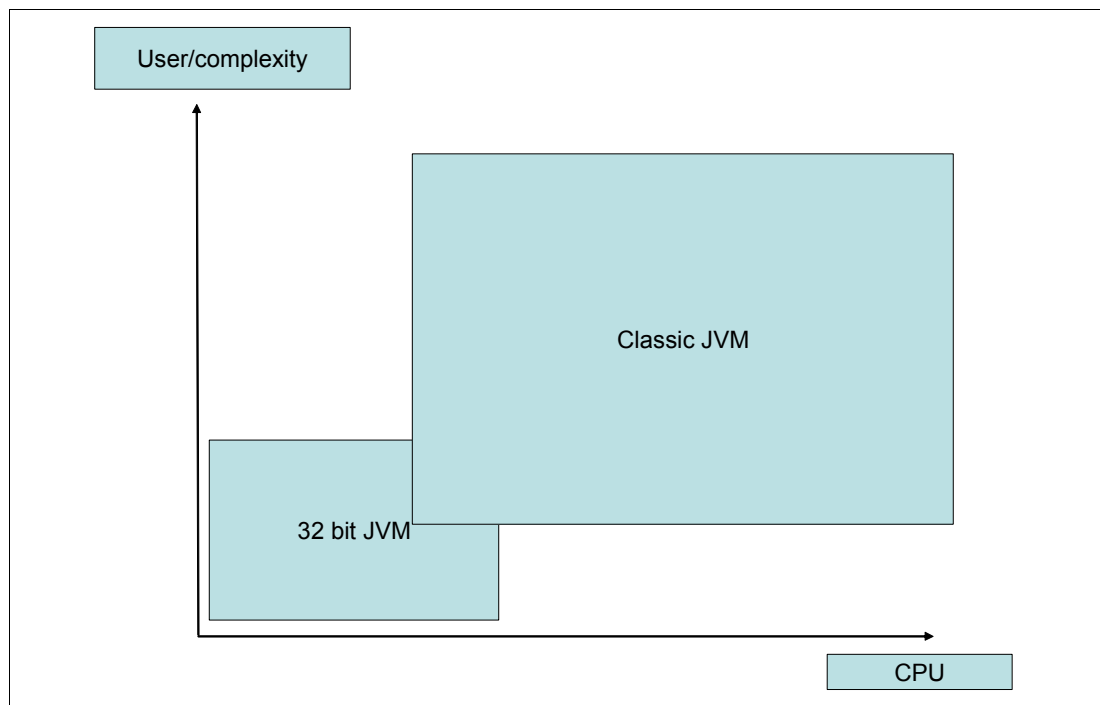

Figure 11-1 Range of application Classic versus IBM Technology for JVM

In addition, IBM can better utilize its research and development effort for creating a single and superior JVM that runs on all IBM platforms.

## 11.2 System requirements for i5/OS

WebSphere Application Server version 6.1 is supported on both Classic JVM and IBM Technology for JVM on i5/OS V5R4M0 or later releases. Earlier versions of WebSphere Application Server are only supported on Classic JVM. i5/OS releases prior to V5R4M0 do not support IBM Technology for JVM. These are the basic requirements for WebSphere Application Server version 6.1 running on V5R4M0. For a complete list of hardware and software prerequisites refer to:

[http://publib.boulder.ibm.com/infocenter/wasinfo/v6r1/topic/com.ibm.websphere.base.iseries.doc/info/series/ae/cins\\_is\\_prqsvr.html](http://publib.boulder.ibm.com/infocenter/wasinfo/v6r1/topic/com.ibm.websphere.base.iseries.doc/info/series/ae/cins_is_prqsvr.html)

Some of the prerequisites are:

- ▶ i5/OS V5R4M0 and cumulative program temporary fix (PTF) package C6192540 or later
- ▶ Java Developers Kit (JDK) V5.0:
  - 5722-JV1 option 7

- 5722-JV1 option 8
- ▶ i5/OS Qshell utilities (5722-SS1 option 30)
- ▶ i5/OS Host Servers (5722-SS1 option 12)
- ▶ i5/OS Extended Base Directory Support (5722-SS1 option 3)
- ▶ i5/OS Portable Application Solutions Environment (5722-SS1 option 33)
- ▶ WebSphere Application Server version 6.1 group PTF SF99323 version 5 or later:
  - DB2 for i5/OS group PTF SF99504 version 4 or later
  - Java group PTF SF99291 version 3 or later
  - HTTP server group PTF SF99114 version 3 or later

**Important:** If you install any of the listed products after you install the i5/OS cumulative PTF package, you must reinstall the cumulative PTF package to ensure that all required PTF are applied. Reinstall the WebSphere Application Server group PTF if you installed 5722-JV1 option 7, 8, or 5722-SS1 option 33 (i5/OS PASE) after installing group PTF.

Refer to the WebSphere Application Server group PTF cover letter for installation instructions. Ensure that you run the *update* script, which actually applies the WebSphere Application Server fixes.

## 11.3 Switching between JVMs in WebSphere Application Server 6.1

WebSphere Application Server 6.1 for i5/OS can run with Classic JVM and IBM Technology for JVM. It includes a Qshell script that can switch between JVMs. In this section, we cover:

- ▶ The *enableJVM* script that specifies the JVM for one or more WebSphere Application Server profiles
- ▶ An example of stopping a profile, changing the JVM, and restarting the profile
- ▶ Switching a Deployment Manager cell to IBM Technology for Java VM
- ▶ How to determine which JVM is in use

### 11.3.1 The enableJVM script

By default, WebSphere Application Server version 6.1 specifies Classic JVM for all profiles that are created.

**Attention:** WebSphere Application Server 6.1 supports installing the product multiple times on the same server or logical partition. To get a list of all of your installed environments, including the default profile location and install library, you can use the following script:

```
/QIBM/ProdData/WebSphere/AppServer/V61/base/bin/querywasinstalls
```

*In these examples the default installation location is assumed.*

WebSphere Application Server version 6.1 for i5/OS includes a Qshell script that can switch the JVM type. If you do not use the default installation directory, adjust these instructions accordingly. The script is located in the following location:

```
/QIBM/ProdData/WebSphere/AppServer/V61/Base/bin/enableJvm
```

This script requires that the user has \*ALLOBJ authority. The command syntax is:

```
enableJVM parameters
```

In the enableJVM parameters command, parameters are:

- ▶ -jvm [std32 | classic]

This is a required parameter that specifies the JVM that is in use:

- std32 = IBM Technology for JVM
- classic = Classic JVM

- ▶ -profile <profile\_to\_be\_enabled>

This is an optional parameter that specifies the profile to enable. If a profile is not specified, *all* profiles are switched to the specified JVM.

- ▶ -verbose

This is an optional parameter that enables additional trace statements.

**Important:** If a profile is not specified, *all* profiles are switched to the specified JVM.

The following list contains several examples:

- ▶ enableJVM -jvm std32 -profile default

Sets the default profile to run on IBM Technology for JVM.

- ▶ enableJVM -jvm classic

Sets *all* profiles to run on Classic JVM.

- ▶ enableJVM -jvm std32 -profile default -verbose

Sets the default profile to run on IBM Technology for JVM and displays additional details on the window.

**Attention:** With WebSphere Application Server Network Deployment V6.1, it is possible to include servers with Classic JVM and IBM Technology for JVM in the same cell.

### 11.3.2 Enabling an existing WebSphere Application Server profile with IBM Technology for JVM

Use the following steps to switch to IBM Technology for JVM:

1. Sign in to the System i platform with an appropriate user ID and password.
2. Enter STRQSH on the CL command line, and press Enter.
3. At the Qshell prompt, run the following command:

```
cd /QIBM/ProdData/WebSphere/AppServer/V61/Base/bin
```

4. If your profile is running, stop it (we use the default profile), as shown in Figure 11-2:

```
stopServer -profileName default
```

```
QSH Command Entry

$
> cd /QIBM/ProdData/WebSphere/AppServer/V61/Base/bin
$
> stopServer -profileName default
ADMU0116I: Tool information is being logged in file
/QIBM/UserData/WebSphere/AppServer/V61/Base/profiles/default/logs/server1/stopServer.log
ADMU0128I: Starting tool with the default profile
ADMU3100I: Reading configuration for server: server1
ADMU3201I: Server stop request issued. Waiting for stop status.
ADMU4000I: Server server1 stop completed.
===>
F3=Exit F6=Print F9=Retrieve F12=Disconnect
F13=Clear F17=Top F18=Bottom F21=CL command entry
```

Figure 11-2 Ending the profile

5. Invoke the enableJVM script (Figure 11-3) to change your profile to use the IBM Technology for JVM:

```
enableJVM -profile default -jvm std32
```

```
QSH Command Entry

> enableJVM -profile default -jvm std32
ADEJ0014I: Enabling profile default to use the specified JVM.
ADEJ0002I: Success: The profile will now use the specified JVM.
$
===>
F3=Exit F6=Print F9=Retrieve F12=Disconnect
F13=Clear F17=Top F18=Bottom F21=CL command entry
```

Figure 11-3 Enable JVM for a specific server profile

6. Start the WebSphere Application Server profile that you changed earlier, as shown in Figure 11-4.

```
startServer -profileName default
```

```
QSH Command Entry

> startServer -profileName default
CPC1221: Job089988/QEJBSVR/SERVER1 submitted to job queue QWASJOBQ in
library QWAS61.
CWNATV00I: Application server server1 in profile default has started and is
ready to accept connections on admin port 9060.
===>
F3=Exit F6=Print F9=Retrieve F12=Disconnect
F13=Clear F17=Top F18=Bottom F21=CL command entry
```

Figure 11-4 Starting the profile

7. Your server must now run in IBM Technology for JVM.

### 11.3.3 Configuring WebSphere Application Server Network Deployment to use IBM Technology for Java VM

When you configure WebSphere Application Server Network Deployment to use IBM Technology for Java VM, there are some additional points for you to consider:

- ▶ For any profile that is part of a Network Deployment cell, the Deployment Manager for the node must be running when the **enableJVM** command attempts to update the profile. The **enableJVM** command updates the master copy of a node's variables.xml (the JAVA\_HOME variable specifically) and then synchronizes the change.
- ▶ When invoking **enableJVM** against a Deployment Manager, only the Deployment Manager server is configured to use the chosen JVM, not the servers that belong to the federated nodes.
- ▶ When choosing the JVM for a server, invoke the **enableJVM** command from the bin directory of the product installation to which the node belongs, for example:  
`/QIBM/ProdData/WebSphere/AppServer/V61/ND/bin`
- ▶ If your Deployment Manager has administrative security enabled, you must provide the administrative user name and password in the soap.client.props file for the node you are enabling:
  - a. Edit the following file (adjust instructions for your profile name and location):  
`/QIBM/UserData/WebSphere/AppServer/V61/ND/profiles/MyAppSvr01/properties/soap.client.props`
  - b. Specify the administrative user name and password for the com.ibm.SOAP.loginUserId and com.ibm.SOAP.loginPassword properties, respectively.

- c. Save the file.
- d. Encode the password in the file using the PropFilePasswordEncoder script, which is located in the <WebSphere\_install\_dir>/bin directory for the product. For our example, run the following two commands to encode the password:

```
cd /qibm/proddata/websphere/appserver/v61/nd/bin
```

```
PropFilePasswordEncoder  
/QIBM/UserData/WebSphere/AppServer/V61/ND/profiles/MyAppSvr01/properties/soap.client.props com.ibm.SOAP.loginPassword
```

In the second command, we provide the absolute path to the location of the properties file.

**Important:** If your Deployment Manager has administrative security enabled, you must provide the administrative user name and password in the soap.client.props file for the node you are enabling.

As an example, we change a WebSphere Application Server profile to use IBM Technology for Java VM.

We used the following environment for this example:

- ▶ Standard installation path for WebSphere Application Server Network Deployment.  
/QIBM/ProdData/WebSphere/AppServer/V61/ND/bin
- ▶ Deployment Manager profile name: MyDmgr
- ▶ Node agent profile name: MyAppSvr01
- ▶ Application server profile (node) name: MyAppSvr01  
/QIBM/UserData/WebSphere/AppServer/V61/ND/profiles/MyAppSvr01

Before we can change the JVM, we need to stop the Application Server and the node agent.

Stop the application server using the following steps.

1. Sign on to the i5/OS with your user profile and password.
2. Start a QShell session with the STRQSH command.
3. At the Qshell prompt, run the command:

```
cd /QIBM/ProdData/WebSphere/AppServer/V61/ND/bin
```

4. Stop the application server using the command:

```
stopServer -profileName MyAppSvr01
```

Figure 11-5 on page 386 shows an example of the output from the **stopServer** command.

```

stopServer -profileName MyAppSvr01
ADMU0116I: Tool information is being logged in file

/QIBM/UserData/WebSphere/AppServer/V61/ND/profiles/MyAppSvr01/logs/MyAppSvr01/s
topServer.log
ADMU0128I: Starting tool with the MyAppSvr01 profile
ADMU3100I: Reading configuration for server: MyAppSvr01
ADMU3201I: Server stop request issued. Waiting for stop status.
ADMU4000I: Server MyAppSvr01 stop completed.

```

Figure 11-5 Stopping application server MyAppSvr01

5. Stop the node agent using the command:

```
stopNode -profileName MyAppSvr01
```

Figure 11-6 shows an example of the output from the **stopNode** command.

```

stopNode -profileName MyAppSvr01
ADMU0116I: Tool information is being logged in file

/QIBM/UserData/WebSphere/AppServer/V61/ND/profiles/MyAppSvr01/logs/nodeagent/st
opServer.log
ADMU0128I: Starting tool with the MyAppSvr01 profile
ADMU3100I: Reading configuration for server: nodeagent
ADMU3201I: Server stop request issued. Waiting for stop status.
ADMU4000I: Server nodeagent stop completed.

```

Figure 11-6 Stopping node agent for application server MyAppSvr01

6. Configure the application server profile MyAppSvr01 to use IBM Technology for Java VM with the following **enableJVM** command:

```
enableJVM -profile MyAppSvr01 -jvm std32
```

Figure 11-7 shows an example of the output of the **enableJVM** command.

```

enableJVM -profile MyAppSvr01 -jvm std32
ADEJ0014I: Enabling profile MyAppSvr01 to use the specified JVM.
ADEJ0015I: Profile MyAppSvr01 is a member of a Network Deployment cell.
Attempting to connect to the deployment manager for this node.
ADEJ0002I: Success: The profile will now use the specified JVM.

```

Figure 11-7 Configuring application server profile MyAppSvr01 to use IBM Technology for Java VM

7. Start the node agent.

```
startNode -profileName MyAppSvr01
```

8. Start the application server.

```
startServer -profileName MyAppSvr01
```

9. See 11.3.5, “Determining the JVM in use” on page 389 to verify that this application server is running on IBM Technology for Java VM.

## 11.3.4 Troubleshooting enableJVM for WebSphere Application Server Network Deployment

If you see messages like those shown in Figure 11-8, the `enableJVM` command is not working correctly, which is most likely due to one of the following causes:

- ▶ The Deployment Manager is not running
- ▶ The Deployment Manager has administrative security enabled but credentials were not supplied or are invalid

### The Deployment Manager for this node is not running

If the error message (Figure 11-8) is displayed soon after you issue the `enableJVM` command (within 30 seconds):

1. Check that the Deployment Manager for this node is running.
2. If the Deployment Manager is not running, start it.
3. After the Deployment Manager is running, issue the `enableJVM` command again.

```
enableJVM -profile MyAppSvr01 -jvm std32
ADEJ0014I: Enabling profile MyAppSvr01 to use the specified JVM.
ADEJ0015I: Profile MyAppSvr01 is a member of a Network Deployment cell. Attempting to
connect to the deployment manager for this
node.
ADEJ0016I: Warning: Unable to connect to the deployment manager server for profile
MyAppSvr01.
To update the variables.xml file for the node, the deployment manager must be active.
ADEJ0003E: Failure: The specified JVM was not enabled. See previous messages for
errors.
```

Figure 11-8 Error after changing JVM for a profile (node)

### The Deployment Manager has administrative security enabled

If the error message is displayed some time after you issue the `enableJVM` command (3-5 minutes):

1. Check if the Deployment Manager has administrative security enabled.
2. Ask the WebSphere Application Server administrator or check the `SystemOut.log` file from the Deployment Manager for the message `SECJ0210I`. If the message is “Security enabled true”, the Deployment Manager has administrative security enabled. For instructions on working with the `SystemOut.log` see 11.3.5, “Determining the JVM in use” on page 389

If administrative security is enabled, follow the next steps to modify the `soap.client.props` file. There are several ways to edit this file, but for this example we used a 5250 display:

1. Sign on to the i5/OS with user ID and password.
2. Start a QShell session with the `STRQSH` command.
3. At the Qshell prompt, run the command:  
`cd /QIBM/ProdData/WebSphere/AppServer/V61/ND/bin`
4. Stop the application server:  
`stopServer -profileName MyAppSvr01`

Figure 11-5 on page 386 shows an example of the output from the **stopServer** command.

```
stopServer -profileName MyAppSvr01
ADMU0116I: Tool information is being logged in file

/QIBM/UserData/WebSphere/AppServer/V61/ND/profiles/MyAppSvr01/logs/MyAppSvr01/s
topServer.log
ADMU0128I: Starting tool with the MyAppSvr01 profile
ADMU3100I: Reading configuration for server: MyAppSvr01
ADMU3201I: Server stop request issued. Waiting for stop status.
ADMU4000I: Server MyAppSvr01 stop completed.
```

Figure 11-9 Stopping application server MyAppSvr01

5. Press the F3 key to exit Qshell.

6. Edit the `soap.client.props` file by issuing the following CL command:

```
EDTF
STMF ('/QIBM/UserData/WebSphere/AppServer/V61/ND/profiles/MyAppSvr01/properties/
soap.client.props')
```

Within the file, search for the following parameters:

```
com.ibm.SOAP.loginUserId=
com.ibm.SOAP.loginPassword=
```

Specify the administrative user name and password for the `com.ibm.SOAP.loginUserId` and `com.ibm.SOAP.loginPassword` parameters, or verify that these values are correct if they are already present.

Figure 11-10 shows an example of working in the `soap.client.props` file.

```
Edit File: rties/soap.client.props
#
#-----
# SOAP Client Security Enablement
#
# - security enabled status ( false[default], true )
#-----
com.ibm.SOAP.securityEnabled=false

com.ibm.SOAP.loginUserId=adminsec
com.ibm.SOAP.loginPassword=security

F2=Save F3=Save/Exit F12=Exit F15=Services F16=Repeat find F17=Repeat
change F19=Left F20=Right
```

Figure 11-10 Adding user ID and password to `soap.client.props` file

7. Press F3 to save your data, and exit the program.

8. Start a QShell session with the STRQSH command.

9. At the Qshell prompt, run the command:

```
cd /QIBM/UserData/WebSphere/AppServer/V61/ND/profiles/MyAppSvr01/bin
```

10. Run the **PropFilePasswordEncoder** command. This command encodes the password that we previously added:

```
PropFilePasswordEncoder  
/QIBM/UserData/WebSphere/AppServer/V61/ND/profiles/MyAppSvr01/properties/soap.c  
lient.props com.ibm.SOAP.loginPassword
```

For further information about the **PropFilePasswordEncoder** command, see:

[http://publib.boulder.ibm.com/InfoCenter/wasinfo/v6r1/index.jsp?topic=/com.ibm.websphere.nd.doc/info/ae/ae/rsec\\_propfilepwdencoder.html](http://publib.boulder.ibm.com/InfoCenter/wasinfo/v6r1/index.jsp?topic=/com.ibm.websphere.nd.doc/info/ae/ae/rsec_propfilepwdencoder.html)

**Important:** The **PropFilePasswordEncoder** command creates a new soap.client.props file and renames the original file to soap.client.props.bak. The new file contains the encoded password. The soap.client.props.bak contains the password in clear text. We strongly recommend that you edit the .bak file, and remove the entry for com.ibm.SOAP.loginUserid and com.ibm.SOAP.loginPassword. It is important to keep this file for future modification. Do not delete the soap.client.props.bak file.

11. Run the **enableJVM** command again.

### 11.3.5 Determining the JVM in use

There are two basic ways to determine which JVM a WebSphere Application Server profile is using:

- ▶ View the job log for your WebSphere Application Server profile.
- ▶ View the SystemOut.log file for your WebSphere Application Server profile.

The job log option is the easier one to use, and the one that we illustrate.

#### View the job log

To view the job log, perform the following instructions:

1. Find your active profile using the **WRKACTJOB SBS(QWAS61)** command.
2. Use option **5** (work with the job), then option **10** (display job log) for the application server job.
3. Press the F10 key to display the detailed messages. If you use Classic JVM, you see the message shown in Figure 11-11 on page 390.

```

                                Display Job Log
                                System:   RCHAS60
Job . . . : MYAPPSVR02   User . . . : QEJBSVR   Number . . . : 113772

Job 113772/QEJBSVR/MYAPPSVR02 started on 08/11/06 at 15:14:44 in subsystem
QWAS61 in QWAS61. Job entered system on 08/11/06 at 15:14:44.
ACGDTA for 113772/QEJBSVR/MYAPPSVR02 not journaled; reason 1.
Java Virtual Machine is Classic.
Server starting with user profile QEJBSVR and JDK 1.5.0.03-_13_feb_2006.
Statistics elapsed time reset.
WebSphere application server MyAppSvr02 ready.

Bottom
Press Enter to continue.

F3=Exit   F5=Refresh   F10=Display detailed messages   F12=Cancel
F16=Job menu   F24=More keys

```

Figure 11-11 Display messages for Classic JVM

If it is IBM Technology for JVM, then you see the message shown in Figure 11-12.

```

                                Display Job Log
                                System:   RCHAS60
Job . . . : MYAPPSVR02   User . . . : QEJBSVR   Number . . . : 113772

Job 113772/QEJBSVR/MYAPPSVR02 started on 08/11/06 at 15:14:44 in subsystem
QWAS61 in QWAS61. Job entered system on 08/11/06 at 15:14:44.
ACGDTA for 113772/QEJBSVR/MYAPPSVR02 not journaled; reason 1.

Java Virtual Machine is IBM Technology for Java. PID(343)
Server starting with user profile QEJBSVR and JDK 1.5.0.

Statistics elapsed time reset.
WebSphere application server MyAppSvr02 ready.

Bottom
Press Enter to continue.

F3=Exit   F5=Refresh   F10=Display detailed messages   F12=Cancel
F16=Job menu   F24=More keys

```

Figure 11-12 Display messages for IBM Technology for JVM

- Note that the process identifier PID(343) is shown in the job log. You can use this information in case you have to do a heap dump or other diagnostics.

### Checking the SystemOut.log

There are several ways to view the SystemOut.log file. In this section, we describe one of ways and tell you how you can use it to verify which JVM is running an application server.

Use the DSPF command from a 5250 display (you should know the name of your profile and installation location). Here we show you how to use this command for the default installation location and default profile:

DSPF

```
STMF('/QIBM/UserData/WebSphere/AppServer/V61/Base/profiles/default/logs/server1/SystemOut.log')
```

You should see the following message if the application server is using Classic JVM:

```
Java version = 1.5.0.03-13_feb_2006, Java Compiler = jitc_de, Java VM name = Classic VM
```

Figure 11-13 shows an extract from the SystemOut.log for a WebSphere Application Server profile that runs in Classic JVM.

```
***** Start Display Current Environment *****
WebSphere Platform 6.1 [BASE 6.1.0.0 b0620.14] running with process name RCHAS60\RCHAS60\server1
Host Operating System is OS/400, version V5R4M0
Java version = 1.5.0.03-13_feb_2006, Java Compiler = jitc_de, Java VM name = Classic VM
was.install.root = /QIBM/ProdData/WebSphere/AppServer/V61/Base
user.install.root = /QIBM/UserData/WebSphere/AppServer/V61/Base/profiles/default
Java Home = /QIBM/ProdData/Java400/jdk15
```

Figure 11-13 Sample SystemOut.log extract for a Classic JVM-enabled WebSphere Application Server

Figure 11-14 shows an extract from the SystemOut.log for a WebSphere Application Server profile that runs in 32-bit JVM. The relevant message is:

```
Java version = J2RE 1.5.0 IBM J9 2.3 OS400 ppc-32 (JIT enabled)
```

```
***** Start Display Current Environment *****
WebSphere Platform 6.1 [BASE 6.1.0.0 b0620.14] running with process name
RCHAS60\RCHAS60\server1
Host Operating System is OS/400, version V5R4M0
Java version = J2RE 1.5.0 IBM J9 2.3 OS400 ppc-32 (JIT enabled)
J9VM - 20060220_05389_bHdSMR
JIT - 20060220_2133_r8
GC - 20060214_AA, Java Compiler = j9jit23, Java VM name = IBM J9 VM
```

Figure 11-14 Using DSPF to view SystemOut.log for a 32-bit JVM-enabled WebSphere Application Server

## 11.4 Configuring the WebSphere Application Server JVM

Configuring the IBM Technology for JVM that is used with WebSphere Application Server is easy if you use the administrative console:

1. In the WebSphere Administrative Console, click **Servers** → **Application Servers** → **<application server name>**.
2. In the application servers configuration panel, click **Java and Process Management** → **Process Definition** → **Java Virtual Machine**. See Figure 11-15 on page 392.

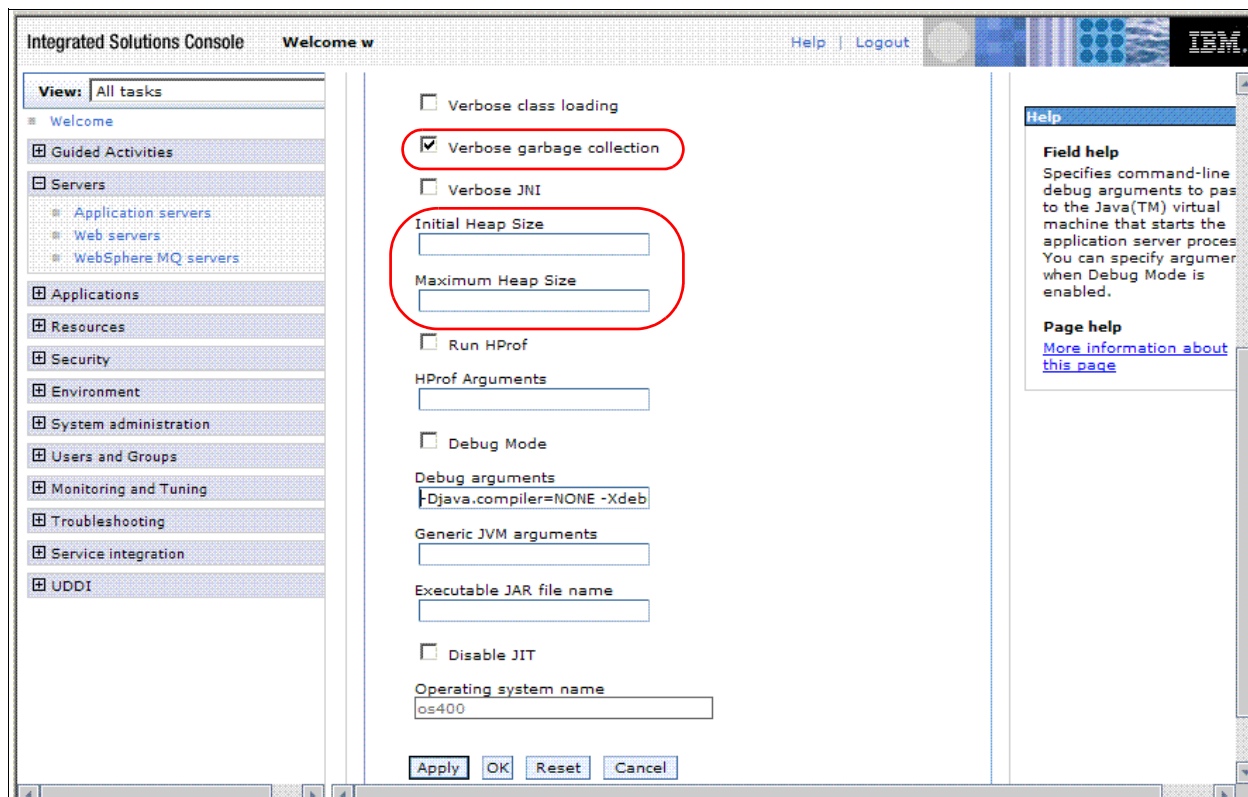

Figure 11-15 WebSphere Application Server V6.1 console makes it easy to customize JVM properties

- In this example, you can see that verbose garbage collection is specified. If you see no values in the Initial Heap Size and Maximum Heap Size fields, then the default values are used:

initial heap size: 50 MB  
maximum heap size: 256 MB

These are defined in the following file:

```
<WAS_install_root>/<edition>/classes/properties/os400j9.systemlaunch.properties
```

- You can change these if you specify the appropriate parameters, and click the **Apply** button. You are then prompted to save or review the changes. Click the **Save** link after you ensure that all parameters are entered correctly.

Note that the generic JVM arguments parameter is blank in Figure 11-15. This tells you that the default garbage collection policy (optimum throughput) is in place.

The following list contains some commonly used JVM arguments for the WebSphere Application Server version 6.1 environment:

- `-agentlib:QWASJVTI` (enables JVM profiling)
- `-Xgcpolicy:optthruput` (specifies the optimum throughput garbage collection policy)
- `-Xgcpolicy:optavgpause` (specifies the minimum average pause garbage collection policy)
- `-Xgcpolicy:gencon` (specifies the generational garbage collection policy)
- `-Xgcpolicy:subpool` (specifies the subpool garbage collection policy)

Because IBM Technology for JVM uses the just-in-time (JIT) compiler exclusively, you do not specify the `-Djava.compiler=jitc` parameter like you do with Classic JVM.

**Attention:** Be very careful when you specify JVM command line arguments. Mistakes as simple as case sensitivity in the parameters can prevent the JVM from starting. JVM command line arguments are specified in the profile's server.xml file.

JVM parameters exclusive to Classic JVM may prevent the IBM Technology for JVM from starting, and vice versa.

**Important:** At the time of this writing, the JVM profiling functions were not working.

5. Restart your WebSphere profile to enable new parameters.

## 11.5 Monitoring the WebSphere Application Server JVM

You can use the measurement and analysis tools with a WebSphere Application Server profile that is running IBM Technology for JVM.

### 11.5.1 Monitoring with Tivoli Performance Viewer

In this section, we illustrate how you can use the Tivoli Performance Viewer, which is integrated in the WebSphere Application Server Administrative Console, to monitor JVM performance. These concepts are applicable to IBM Technology for JVM and Classic JVM:

1. In the WebSphere Administrative Console, click **Monitoring and Tuning** → **Performance Monitoring Infrastructure (PMI)** → *<application server name>*.
2. At the Performance Monitoring Infrastructure (PMI) panel, you are in the Configuration tab, which specifies the monitoring settings when the application server starts. The default settings are PMI enabled, with the basic statistic set.
3. Click the **Runtime** tab (see Figure 11-16 on page 394), which enables you to dynamically specify the performance monitoring policies.

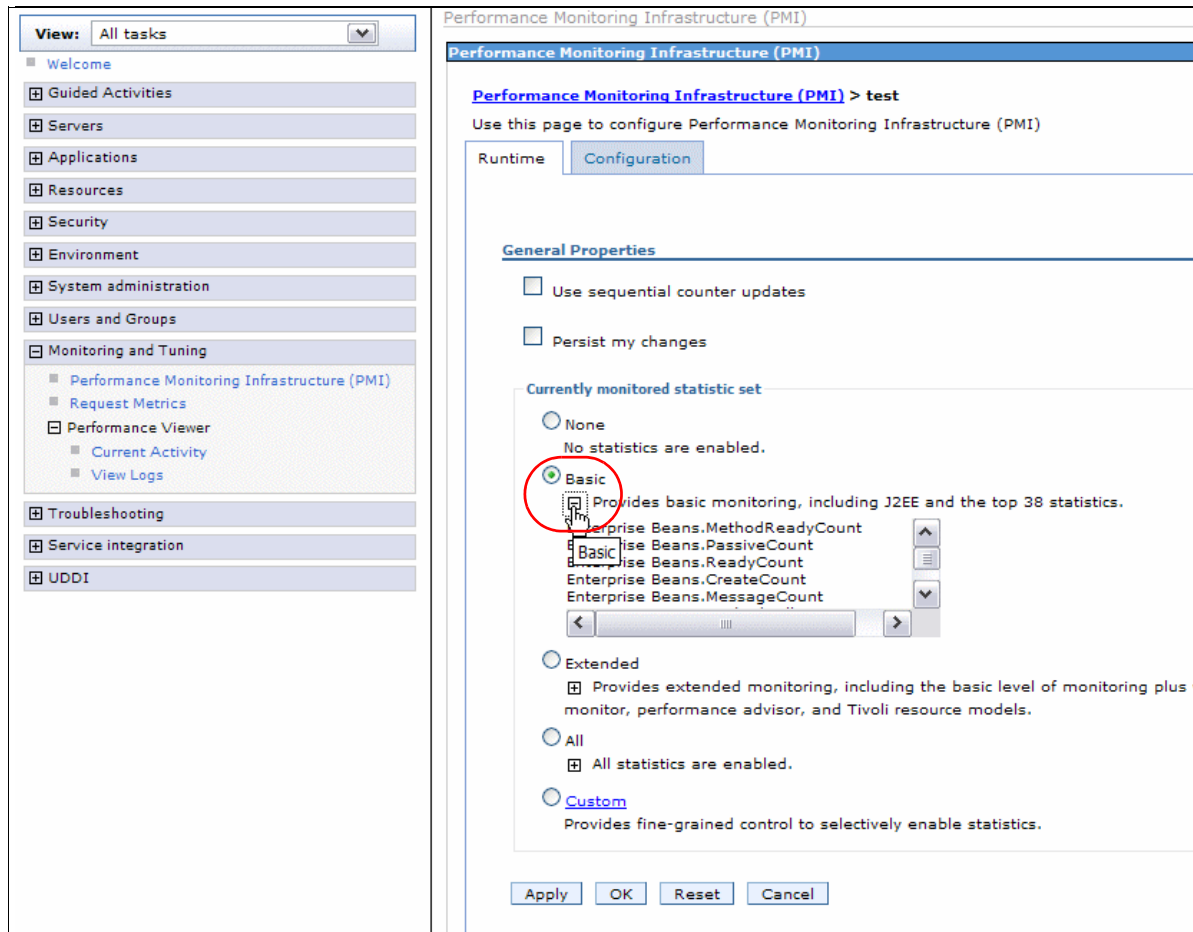

Figure 11-16 Configuring PMI

4. Expand the basic monitoring statistic link, and scroll down to the JVM options. You must see the following JVM metrics available for monitoring:
  - JVM Runtime.ProcessCpuUsage (the percentage of CPU usage of the JVM runtime)
  - JVM Runtime.UpTime (the total time, in seconds, that the JVM has been running)
  - JVM Runtime.UsedMemory (the used memory, in KB, of the JVM runtime)
  - JVM Runtime.HeapSize (the total memory, in KB, of the JVM runtime)

The following metrics are available if JVM profiling is enabled:

- Garbage Collection.GCTime
- Garbage Collection.GCIntervalTime
- Garbage Collection.GCCount
- Object.ObjectFreedCount
- Object.ObjectAllocateCount
- Object.ObjectMovedCount
- Thread.ThreadEndedCount
- Thread.ThreadStartedCount
- Monitor.WaitForLockTime
- Monitor.WaitsForLockCount

5. Under the Monitoring and Tuning section, in the Navigation tree, click **Performance Viewer** → **Current Activity** → **<application server name>**.

- Expand the **Performance Modules** link, and click the **JVM Runtime** box. See Figure 11-17.

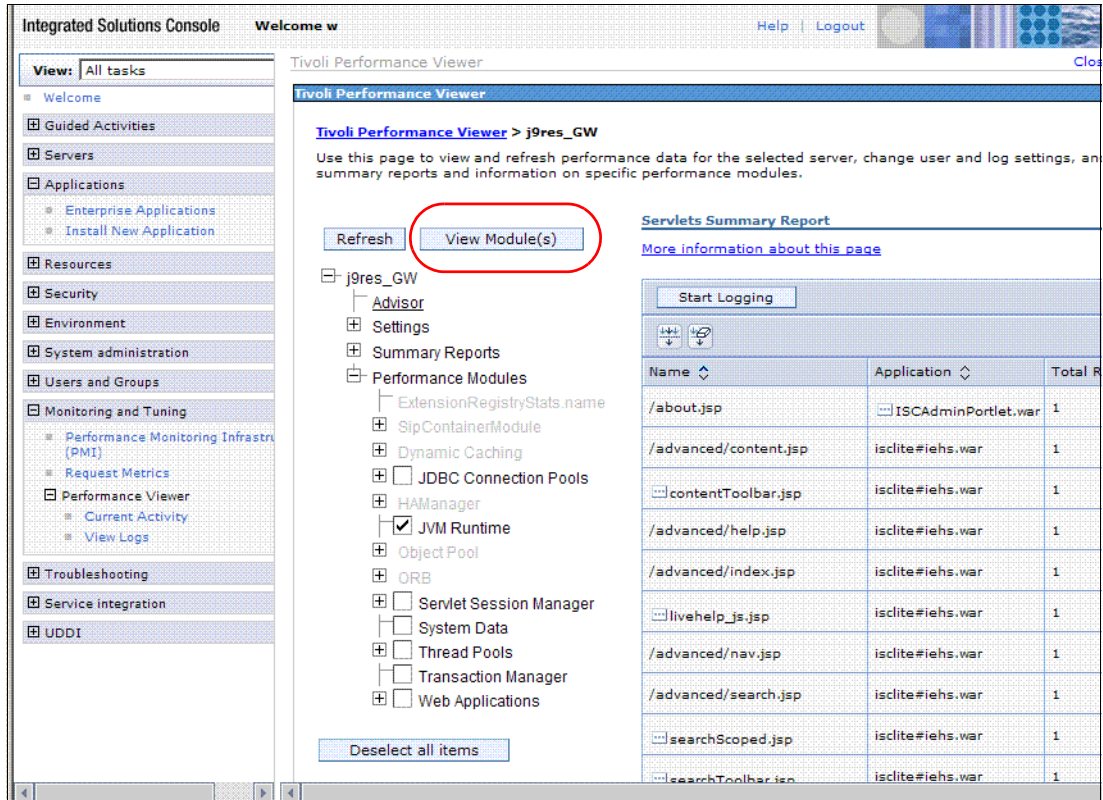

Figure 11-17 Select the JVM runtime statistics for viewing

- Click the **View Module(s)** button to see the JVM runtime data.
- You must see the JVM statistics in either table or graphic format (Figure 11-18 on page 396). The following are the requirements for viewing graphics:
  - The Adobe® Scalable Vector Graphics plug-in for your browser
  - i5/OS PASE (required for IBM Technology for JVM)
  - Set the following parameters in the `os400j9.systemlaunch.properties` file:

```
-Djava.awt.headless=true
-Dos400.awt.native=true
```

This file is located in:

```
<WAS_install_root>/<edition>/classes/properties/os400j9.systemlaunch.properties
```

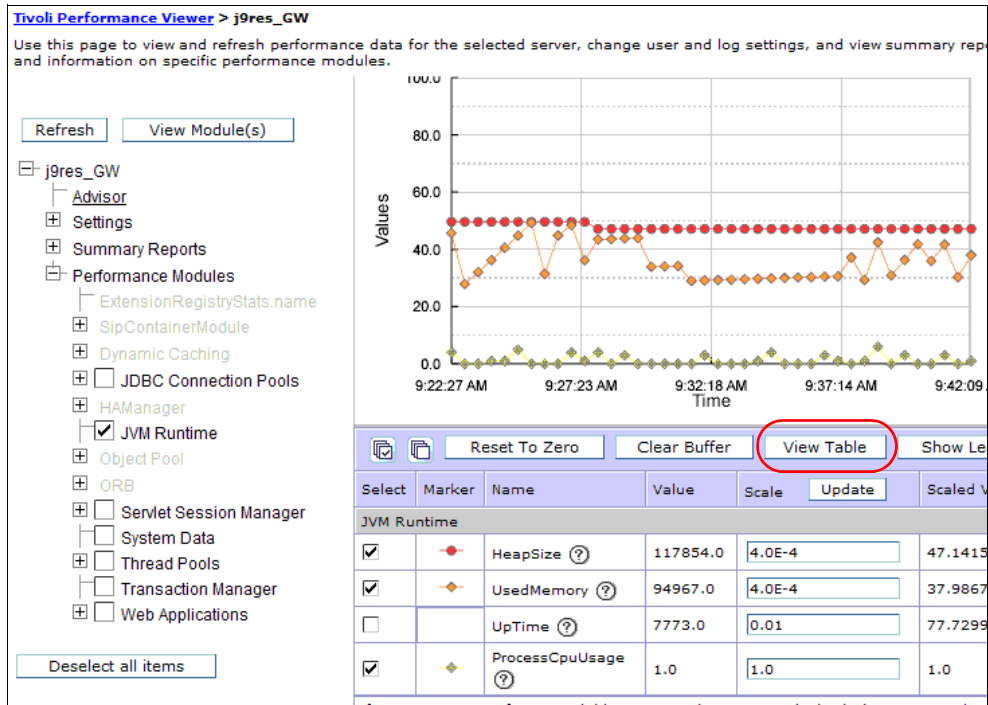

Figure 11-18 View a graphical representation of the JVM runtime

In Figure 11-18, you can also see that the total heap size is relatively constant and that CPU usage is minimal.

Figure 11-18 shows an example of the JVM runtime data in graphical format. In this case, the graph scaling was modified to improve the view in order to see how the used memory changes.

- Figure 11-19 shows an example of the JVM runtime data in tabular format. You can switch to this view by clicking the View Table button.

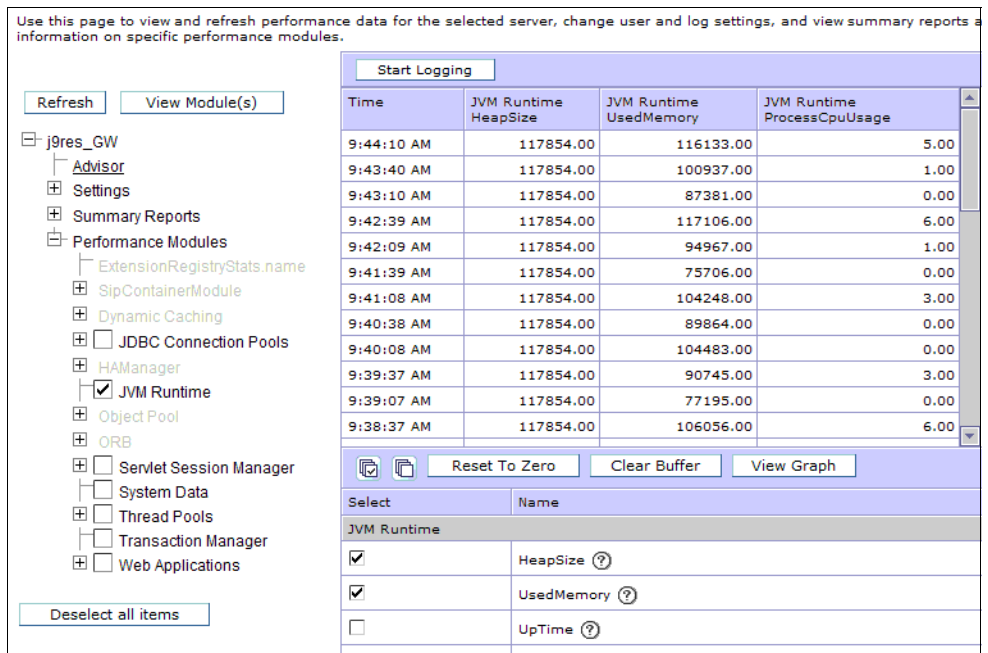

Figure 11-19 View a tabular representation of the JVM runtime

10. You can use the Tivoli Performance Viewer to get a view of your JVM's memory usage. If the memory usage is fairly consistent over time, it is a good indicator that currently there are no memory leaks in your applications.

On the other hand, if memory usage continues to grow, even with a steady workload, it might indicate a memory leak, and you have to analyze the problem in more detail.

## 11.6 Verbose Garbage Collection and logging

You can enable Verbose Garbage Collection for IBM Technology for JVM or Classic JVM using the WebSphere Application Server Administrative Console by selecting the **Verbose garbage collection** check box, as indicated in Figure 11-15 on page 392. By default Verbose Garbage Collection statistics is written to the following directory:

```
<WAS_install_root>/<edition>/profiles/<profile>/logs/<profile>
```

In this directory, the Verbose Garbage Collection statistics are written to the following files:

- ▶ For IBM Technology for JVM: native\_stderr.log
- ▶ For Classic JVM: native\_stdout.log

The SystemOut.log file, in the aforementioned directory, includes helpful JVM information. The excerpt in Example 11-1 shows that the IBM Technology for JVM is used.

*Example 11-1 Excerpt showing the use of IBM Technology for JVM*

---

```
WebSphere Platform 6.1 [BASE 6.1.0.1 cf10631.18] running with process name
RCHAS60_j9res_GW\RCHAS60_j9res_GW\j9res_GW and process id 212236/QEJBSVR/J9RES_GW
Host Operating System is OS/400, version V5R4M0
Java version = J2RE 1.5.0 IBM J9 2.3 OS400 ppc-32 (JIT enabled)
J9VM - 20060501_06428_bHdSMR
JIT - 20060428_1800_r8
GC - 20060501_AA, Java Compiler = j9jit23, Java VM name = IBM J9 VM
```

---

The excerpt in Example 11-2 shows the heap monitor status during the server startup and the i5/OS memory pool details.

*Example 11-2 Excerpt showing heap monitor status during server startup*

---

```
Heap Monitor started for 212236/QEJBSVR/J9RES_GW in subsystem QWAS61
in Pool *BASE pool ID=2
Poolsize(MB)=25107 Reserved(MB)=2
Heap total(MB)=50 Free(MB)=19 UsedHeap(MB)=30
MaxHeap(MB)=256
InitHeap(MB)=50
```

---

Example 11-3 is an example of the Verbose Garbage Collection data.

*Example 11-3 Verbose garbage collection data*

---

```
<af type="tenured" id="34" timestamp="Mon Oct 09 15:14:49 2006"
intervalms="3510.159">
  <minimum requested_bytes="24" />
  <time exclusiveaccessms="0.092" />
  <tenured freebytes="368128" totalbytes="146692096" percent="0" >
    <soa freebytes="0" totalbytes="146323968" percent="0" />
    <loa freebytes="368128" totalbytes="368128" percent="100" />
```

```
</tenured>
<gc type="global" id="34" totalid="34" intervalms="3531.284">
  <refs_cleared soft="8" weak="3" phantom="12" />
  <finalization objectsqueued="168" />
  <timesms mark="234.412" sweep="7.486" compact="0.000" total="242.215" />
  <tenured freebytes="49852368" totalbytes="146692096" percent="33" >
    <soa freebytes="49631184" totalbytes="146470912" percent="33" />
    <loa freebytes="221184" totalbytes="221184" percent="100" />
  </tenured>
</gc>
<tenured freebytes="49851672" totalbytes="146692096" percent="33" >
  <soa freebytes="49630488" totalbytes="146470912" percent="33" />
  <loa freebytes="221184" totalbytes="221184" percent="100" />
</tenured>
<time totalms="247.748" />
</af>
```

---

**Tip:** We recommend that you collect the Verbose GC output to a separate file using the `-Xverbosegclog` parameter in the Generic JVM arguments field.

## 11.7 Additional information

The WebSphere Application Server information center also has helpful information. It is available at:

[http://publib.boulder.ibm.com/infocenter/wasinfo/v6r1/topic/com.ibm.websphere.base.iseries.doc/info/welcome\\_base.html](http://publib.boulder.ibm.com/infocenter/wasinfo/v6r1/topic/com.ibm.websphere.base.iseries.doc/info/welcome_base.html)

You can also read the following IBM Redbooks publication:

*IBM Technology for Java Virtual Machine in IBM i5/OS*, SG24-7353



# A

## Downloading PTFs using Fix Central

Fix Central provides a fast and easy method to obtain program temporary fixes (PTFs). By using the File Transfer Protocol (FTP) download option, you can download and install individual PTFs, group PTFs, and cumulative PTF packages from Fix Central directly onto your i5/OS server. You also have the option to use the browser-based HTTP download method to receive some of the smaller PTFs that you might require.

In this section, we focus on using the FTP method. We provide a step-by-step guide on how to use this Fix Central capability to download the latest WebSphere Application Server V6.1 Group PTF.

When you use the FTP option, you typically select the PTFs that you require, and create an online order for those PTFs. The Fix Central server processes your order and stores your PTFs in a directory on a remote server. You then receive an automated e-mail notification to advise you that your PTF order is ready and that you can retrieve your PTFs from the remote server.

# Ordering your PTFs

To order your PTFs:

1. Go to Fix Central at the following Web address:  
<http://www.ibm.com/eserver/support/fixes/fixcentral/main/iserie>
2. Select your PTF requirements from the drop-down lists, as shown in Figure A-1, and click **Continue** to proceed. Several useful options are available for the Ordering option field.

The screenshot shows the 'Fix Central' web page. At the top, it says 'Fix Central provides fixes and updates for your system's software, hardware, and operating system.' Below this are four dropdown menus: 'Product family' (set to 'System i family'), 'Product' (set to 'i5/OS and OS/400'), 'Ordering option' (set to 'Groups, HIPER, Cumulative fixes'), and 'OS level' (set to 'V5R4'). At the bottom left is a blue 'Continue' button with a right-pointing arrow.

Figure A-1 Specifying the PTF requirements on Fix Central

3. On the next page, enter your IBM ID and password, as shown in Figure A-2, and then click **Sign in**. If you currently do not have an IBM ID, you can register by selecting the **Need an IBM ID?** link in the frame on the right.

The screenshot shows the 'Sign in' page on the IBM eServer website. The top navigation bar includes the IBM logo, a 'Country/region [select]' dropdown, and a 'Terms of use' link. Below the navigation bar is a search bar with a 'Search' button. The main content area features a 'Sign in' heading and a form with two input fields: 'IBM ID' (containing 'ITSO1') and 'Password' (containing '\*\*\*\*\*'). A blue 'Sign in' button is positioned below the password field. To the right of the sign-in form is a 'Registration help' section with four links: 'Need an IBM ID?', 'Change profile', 'Change password', and 'Forgot your IBM ID or password?'. On the left side, there is a vertical menu with various server categories like 'IBM servers', 'Blade servers', etc.

Figure A-2 Signing in to Fix Central

4. On the Group, HIPER, and Cumulative page, select the PTFs that you want to download from the list, and click **Add to my download list**.

You can select multiple PTFs to download from this page by pressing and holding down the Ctrl key and selecting each of the PTFs that you want to download. Remember to click the **Add to my download list** icon to save the selected PTFs in your download basket.

If you want to view or print the PTF cover letter before you download it, select the PTF and click the **View fix details** icon.

After you add all of your required PTFs to your download basket, click **Continue**.

5. On the Packaging options page (Figure A-3), specify any additional PTF ordering requirements that you might have.

You might select the tool to connect to your system to check for required PTFs, if you are not sure what PTFs are required.

In our example, we select to download the CD images using the Download director-applet based tool for quick download of the large files. Using this method, we can download any group or hiper PTF before we start a product installation. Click **Continue**.

**Fix Central**  
Help  
Feedback

**Related links**  
• Technical databases  
• Information center

## Packaging options

Select packaging options. You can build a fix package tailored for a specific system or a more general package for all your systems.

**Order name**

Provide a name to identify this order for viewing at a later time  
Order name:

**Ordering options**

Connect to my system and continue ordering. Select additional options below.

- Include requisite PTFs
- Order only PTFs required by the system to which I am connecting.
- Order all PTFs so they can be applied to multiple systems

Do not connect to my system and continue ordering. Select additional options below.

- Include requisite PTFs
- Download virtual images using Download director
- Download virtual images using FTP

Email address \*   
Directory name   
Base file name

Cover Letters only (Immediate download to system) [Help](#)

[Continue](#) [View download list](#) [Modify download list](#)

Figure A-3 PTF packaging options

If you choose to connect to your system, follow the instructions in “Directly downloading and installing the PTFs to an i5/OS system” on page 409.

- On the next page, the tool informs you about the order status (Figure A-4). It refreshes every 10 seconds. When your order is prepared, you can download it.

**Fix Central**  
**Help**  
**Feedback**

**Related links**

- Technical databases
- Information center

## Processing order

The order is being processed.

This page will check the status of your order every 10 seconds. You will be redirected to the *Summary* page when the order has completed processing.

Checking order status in 07 seconds.

If this page does not automatically refresh within 10 seconds, [click here to check your order status.](#)

Figure A-4 Order is processing

- The next page shows you the summary, which includes the download link and approximate time when your order will be available (see Figure A-5).

**Fix Central**  
**Feedback**

## Summary

**Your order will be sent to the download server**

The Fix Central function has completed.

Your order has been sent for processing. The *Order available after* time is an approximation of when the order will be ready. Return to Fix Central after that time and you can use the *Resume pending orders* option from the entry page to select the order and start the download.

Order available after: November 14, 2007 2:32PM GMT-06:00

**Download fixes when they become available**

The following information is a summary of the processed order.

Requested PTFs		
PTF	Status	Product description
SF99323	ordered	

**Contact information**

E-mail address: **alekn@us.ibm.com**

**Order information**

Order name:	<b>2007-11-14 13:59:15.291</b>
Order number:	<b>419459</b>
Order available after:	<b>November 14, 2007 2:32PM GMT-06:00</b>
Order Cover Letters only:	<b>No</b>
Do not connect to my system and continue ordering.	<b>Yes</b>
Include requisite PTFs:	<b>Yes</b>
Download CD-ROM image to FTP server (FTP):	<b>No</b>
Download CD-ROM image to DDP server (DDP):	<b>Yes</b>

Figure A-5 Summary page

- Click the download link some time after the estimated download time. The next page shows you the order (Figure A-6). Select the radio button located next to the order, and click **Continue**. If you see the summary page again, it means the order is not ready yet. Wait for some time and try again.



Figure A-6 Resuming order page

- When your order is ready, you should see a new page (Figure A-7) with information about the download. Click the **Download now** link.

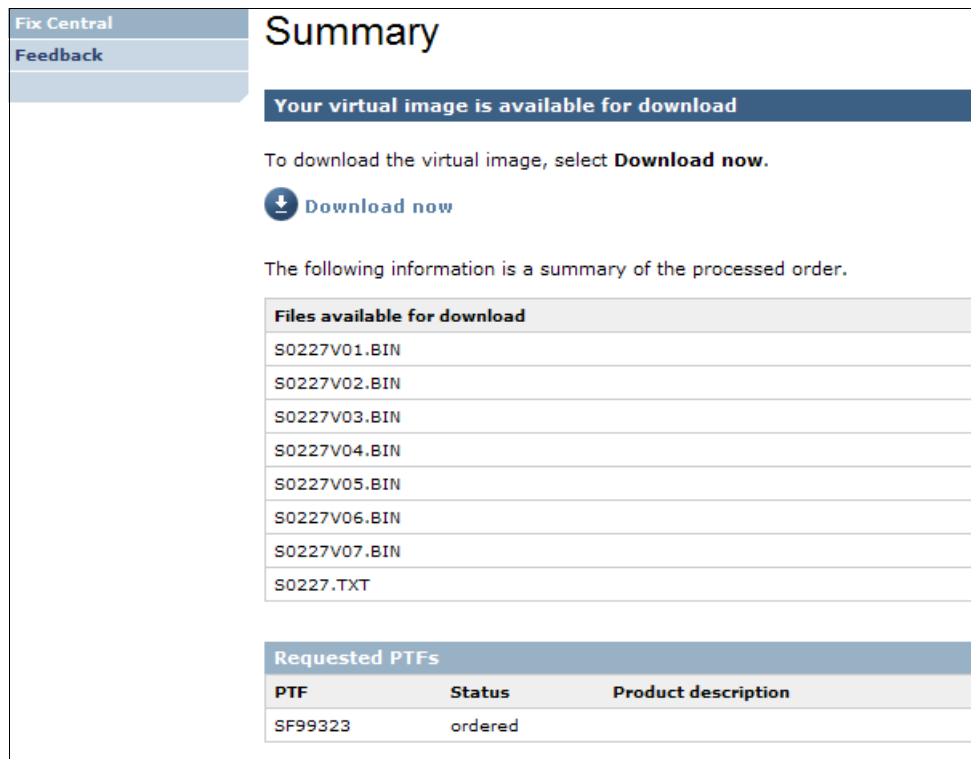

Figure A-7 Download now page

- A new Download director window is displayed. If you use this tool for the first time, it asks you for some settings. The default values are fine. Record the location of the download directory.

A download progress is displayed in the Download director window, as shown in Figure A-8.

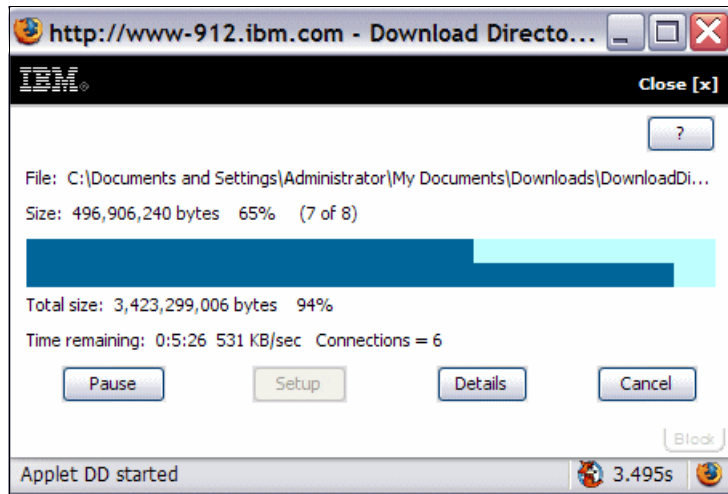

Figure A-8 Download director applet window

11. When you see that the download is complete, close the window. You have the CD images on your workstation. Now you need to move them to your i5/OS system.

## Moving your PTFs to an i5/OS system

To retrieve the PTFs directly into an integrated file system directory on your i5/OS server, you must ensure that your PC workstation can access the integrated file system directory that you want to use. The following steps briefly explain how you can do this using i5/OS Navigator:

1. Right-click the integrated file system directory where you want to save the PTFs, and select **Sharing** → **New Share**, as shown in Figure A-9 on page 405.

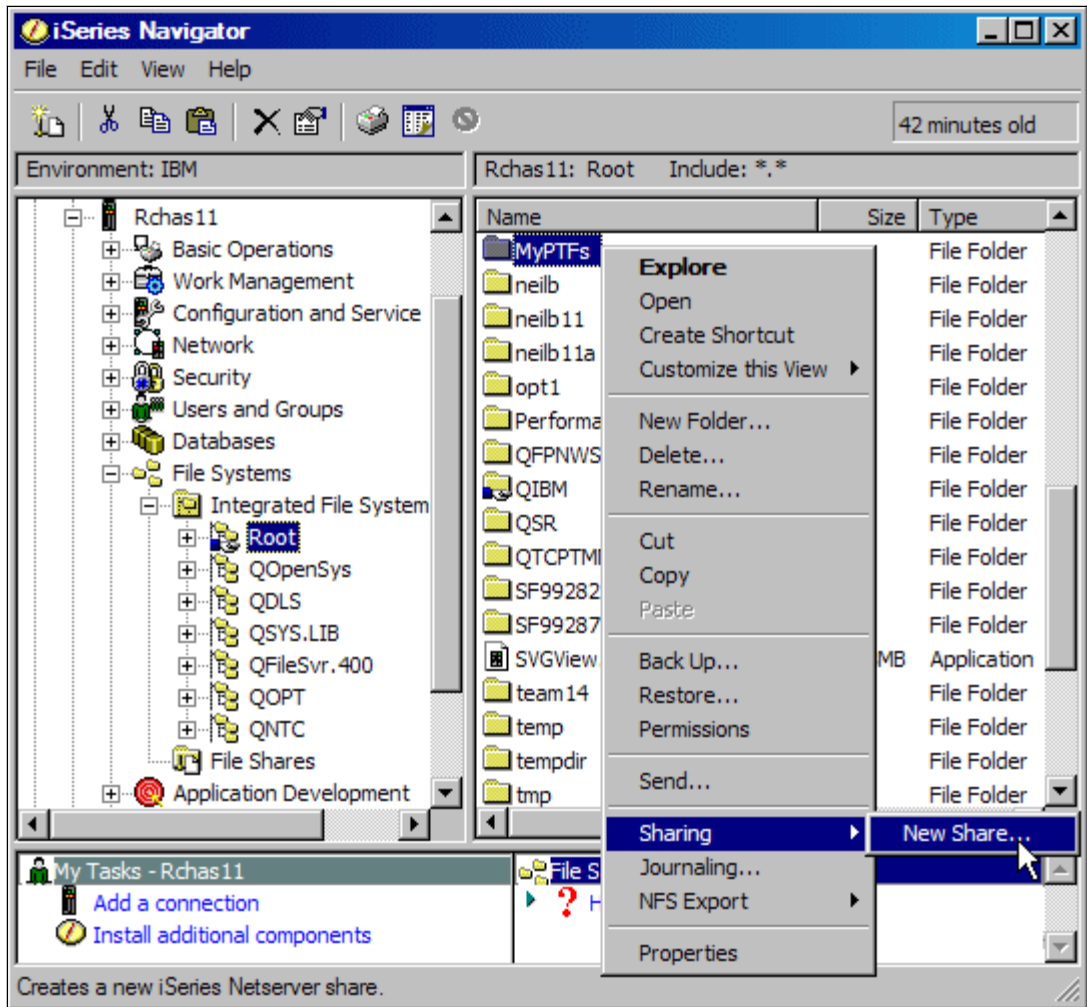

Figure A-9 Enabling integrated file system directory sharing

2. In the i5/OS NetServer™ File Share window (Figure A-10), specify the name and a brief description for your shared directory. Make sure that you allow read and write access to this directory. Click **OK**.

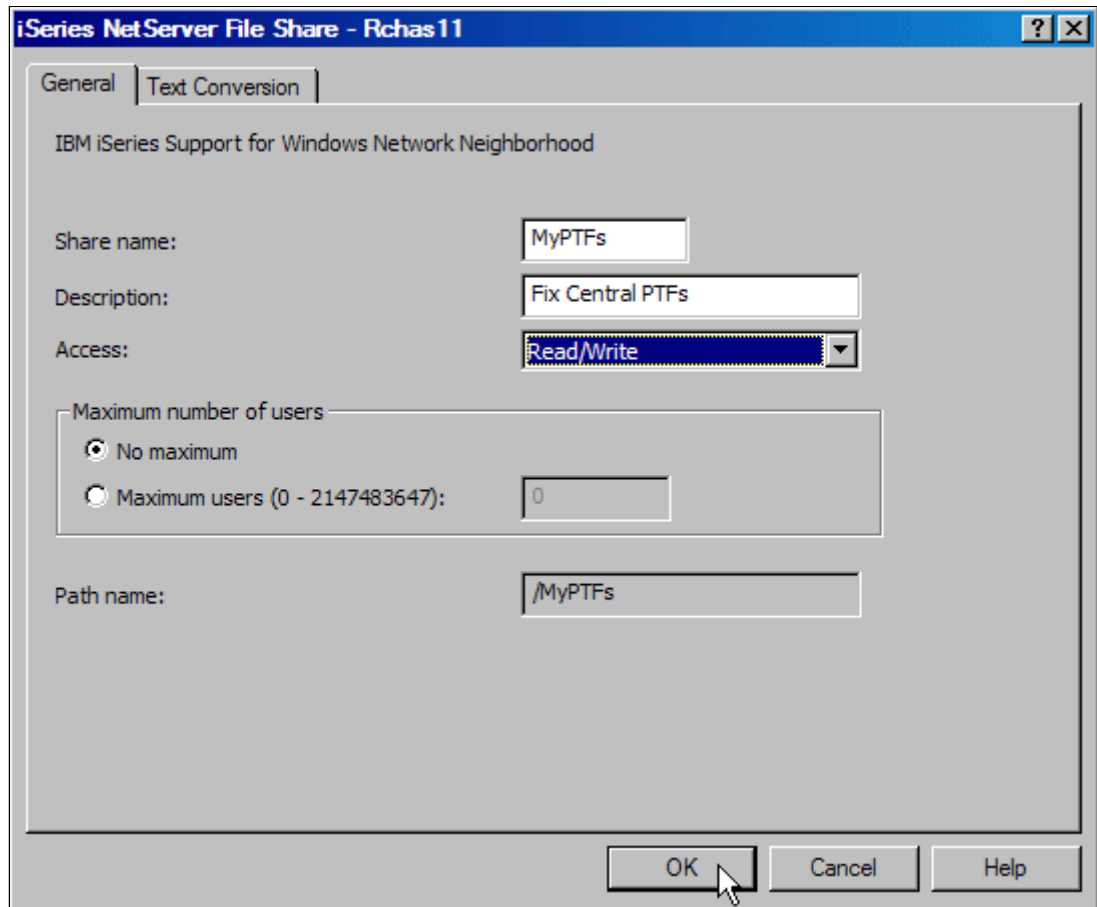



Figure A-10 Creating the integrated file system shared directory

Notice how the display icon for your newly shared directory changes, similar to the one shown here .

3. Open a Windows Explorer session on your PC, and select the **Tools** → **Map Network Drive** option.
4. In the Map Network Drive window (Figure A-11 on page 407), complete the following steps:
  - a. From the Drive list, select an unassigned drive letter. We selected drive letter **Q**.
  - b. In the Folder field, specify the full path name of your shared directory on the i5/OS server. Make sure that you use the Windows operating system format when you specify this path.
  - c. If your Windows logon information differs from your i5/OS user ID and password, click the **different user name** link, and specify your i5/OS user ID and password.
  - d. Click **Finish** to complete your drive mapping process.

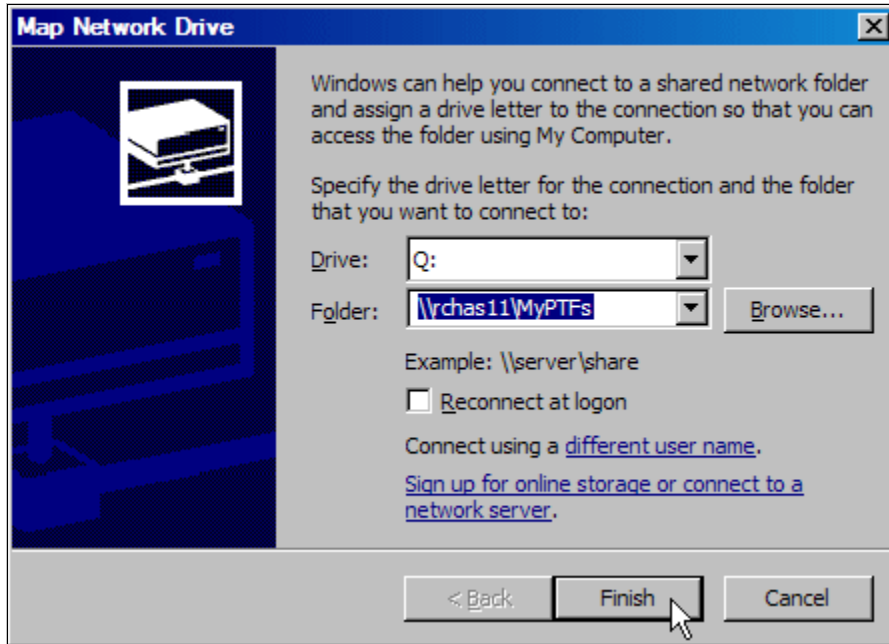

Figure A-11 Mapping a network drive in Windows Explorer

5. You can copy the downloaded CD images to your i5/OS system using the mapped network drive.

Now that you successfully retrieved all of your PTFs from the Fix Central remote server, you can install the PTFs on your i5/OS server.

## Installing your PTFs

You can install your PTFs by using an *image catalog*:

1. Make sure that you have a *virtual optical device* configured on your i5/OS that you can use to install your PTFs. You can verify that you already have a virtual optical device configured using the following OS/400 command:
 

```
WRKDEVD DEVD(*OPT)
```
2. Identify the virtual optical device by its associated device type, which is 632B.
3. If you do not already have a virtual optical device configured, you can use the CRTDEVOPT OS/400 command to create one, for example:
 

```
CRTDEVOPT DEVD(OPTVRT01) RSRNAME(*VRT) ONLINE(*YES) TEXT('Virtual Optical device')
```
4. Make sure that the virtual optical device is active using the Vary Configuration (VRYCFG) OS/400 command, for example:
 

```
VRYCFG CFGOBJ(OPTVRT01) CFGTYPE(*DEV) STATUS(*ON)
```
5. Create an image catalog using the Create Image Catalog (CRTIMGCLG) OS/400 command, and associate the image catalog with the integrated file system directory that contains your PTFs, for example:
 

```
CRTIMGCLG IMGCLG(WAS_PTFGRP) DIR('/MyPTFs') TEXT('WebSphere Application Server Group PTF')
```

6. Add your PTFs to the image catalog using the Add Image Catalog Entry (ADDIMGCLGE) OS/400 command, for example:

```
ADDIMGCLGE IMGCLG(WAS_PTFGRP) FROMFILE('/MyPTFs/S0227V1.bin') TOFILE(*fromfile)
```

The image catalog entry corresponds to the CD-ROM image of the PTFs that you downloaded.

**Note:** If your PTFs consist of multiple CD-ROM images or if your PTFs consist of more than one *.bin* file, you must add each of the *.bin* files to the image catalog by executing the ADDIMGCLGE command for each *.bin* file.

7. Load the image catalog in the virtual optical device using the Load Image Catalog (LODIMGCLG) OS/400 command, for example:

```
LODIMGCLG IMGCLG(WAS_PTFGRP) DEV(OPTVRT01) OPTION(*LOAD)
```

8. Verify that your CD-ROM images are loaded in the correct sequence in the image catalog using the Verify Image Catalog (VFYIMGCLG) OS/400 command, for example:

```
VFYIMGCLG IMGCLG(WAS_PTFGRP) TYPE(*PTF) SORT(*YES)
```

This command automatically sorts the CD-ROM images that contain the PTFs in the correct order. This step is especially important if your PTFs consist of multiple CD-ROM images.

9. Install your PTFs using the installation method as recommended in the documentation of your PTFs. Figure A-12 shows an example of the input parameters to install a group PTF using an image catalog.

Install Options for Program Temporary Fixes		System: RCHAS11
Type choices, press Enter.		
Device . . . . .	OPTVRT01	Name, *SERVICE, *NONE
Automatic IPL . . . . .	Y	Y=Yes N=No
Prompt for media . . . . .	1	1=Single PTF volume set 2=Multiple PTF volume sets 3=Multiple volume sets and *SERVICE
Restart type . . . . .	*SYS	*SYS, *FULL
Other options . . . . .	N	Y=Yes N=No
F3=Exit F12=Cancel		

Figure A-12 Installation options for the group PTF

You can find additional information about installing PTFs from an image catalog, see “Install fixes from an image catalog” in the System i Information Center at the following Web address:

<http://publib.boulder.ibm.com/InfoCenter/iserries/v5r4/index.jsp?topic=/rzam8/rzam8/fixinstallimage.htm>

For information about how to download and install PTFs using different methods than the ones that we described here, see “Installing fixes from the FTP Server” at the following Web address:

<http://www-912.ibm.com/supporthome.nsf/document/27321011>

## Directly downloading and installing the PTFs to an i5/OS system

If you select to connect to your system in Fix Central, continue with the following instructions:

1. Figure A-13 starts an applet to connect to your system. Enter the sign on information, and click **Continue**.

Fix Central  
Help  
Feedback

### Order fixes

Fix Central Client

Sign on to your iSeries or AS/400 system that is the target system for the fixes.

iSeries name or TCP/IP address

User ID

Password

View or update your shipping information for this order

[Back](#) [Continue](#) [Cancel order](#) [Your privacy](#) [Help](#)

Figure A-13 Connecting to your system

2. In the next window, check your profile data, and click **Continue**.
3. In the next window, you can select the download option: **immediate HTTP download** or **downloading the CD images using the Download director**. You can leave the default settings, and click **Continue**.
4. The next window prompts you to select the download speed for immediate connection and the temporary directory for storing files. Change these settings if needed, and click **Continue**. The tool attempts to check your system, and selects the download method based on the size of a chosen PTF.

If everything is correct, you should see a download status window as shown in Figure A-14 on page 410.

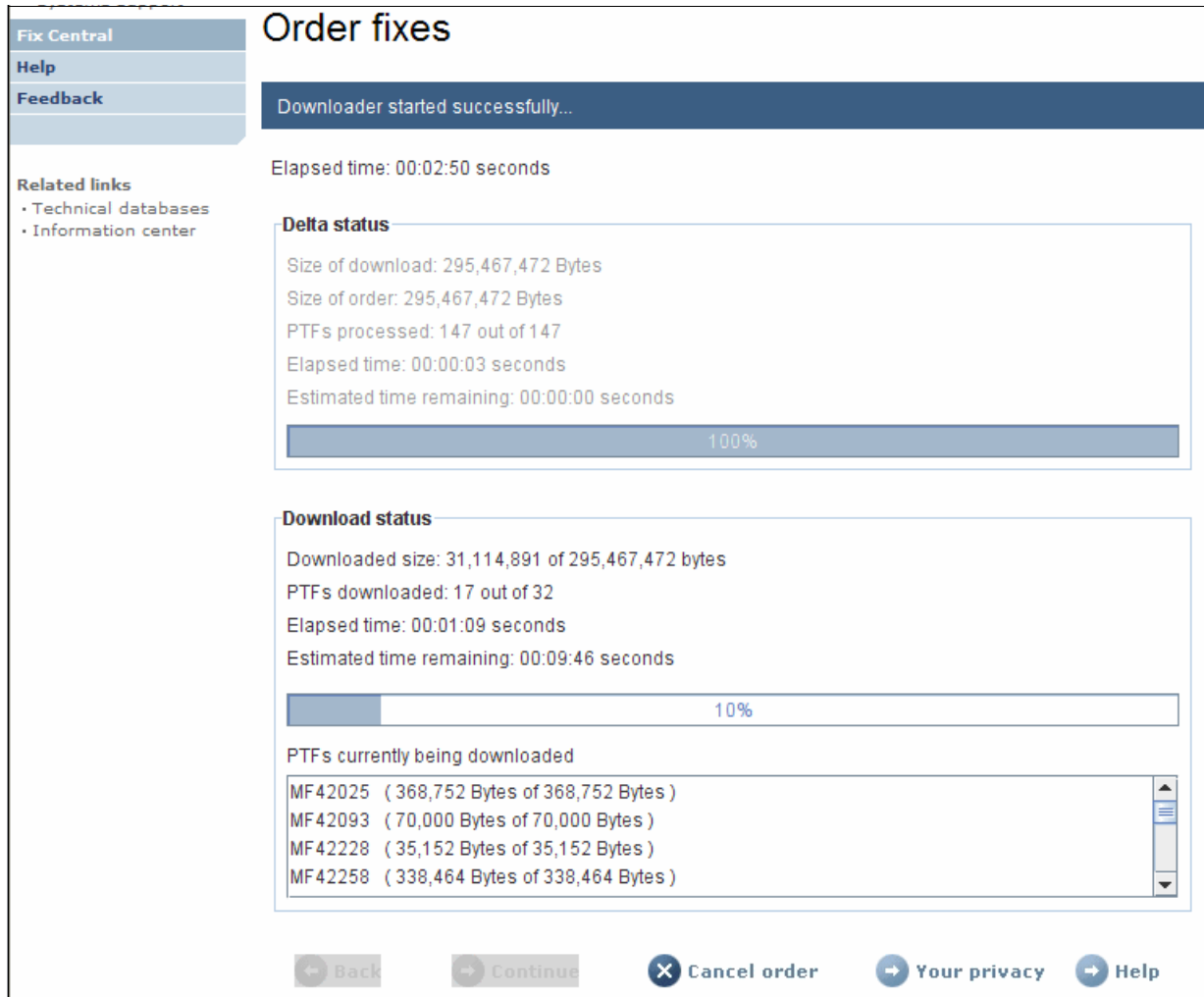

Figure A-14 Download status

5. When the download is complete, you should have all PTFs on your i5/OS system. Start a 5250 emulation to your system, and sign on.

**Note:** The tool also creates a save file on your workstation. The default location on a Windows workstation is:

```
c:\Documents and Settings\\fixcentral\
```

6. Execute the **go ptf** command:
7. Type 8 (the Install program temporary fix package option), and press Enter.
8. Type \*SERVICE in the Device field. You can change other options, as shown in Figure A-15 on page 411, and press Enter.

```

Install Options for Program Temporary Fixes
                                           System:  RCHAS07
Type choices, press Enter.

Device . . . . . *SERVICE      Name, *SERVICE, *NONE
Automatic IPL . . . . . N          Y=Yes
                                           N=No

Prompt for media . . . . . 1      1=Single PTF volume set
                                           2=Multiple PTF volume sets
                                           3=Multiple volume sets and *SERVICE

Restart type . . . . . *SYS       *SYS, *FULL

Other options . . . . . Y         Y=Yes
                                           N=No

F3=Exit  F12=Cancel

```

Figure A-15 Installing fixes

9. If you select **Y** in the Other options field, you should see another window. You can change any option on this window, and press Enter. Your PTFs are installed. You might need to IPL the system.





# B

## **WebSphere fix maintenance**

In this appendix, we discuss how you can install and manage the WebSphere Application Server fixes in addition to loading them with the group PTF.

# Installing individual fixes

Although the recommended way to patch your WebSphere Application Server environment is to install the fix packs contained in the group PTFs, sometimes you will need a specific fix for your installation. You can download the fixes from the IBM Support page (Figure B-1) at:

<http://www-306.ibm.com/software/webservers/appserv/was/support/>

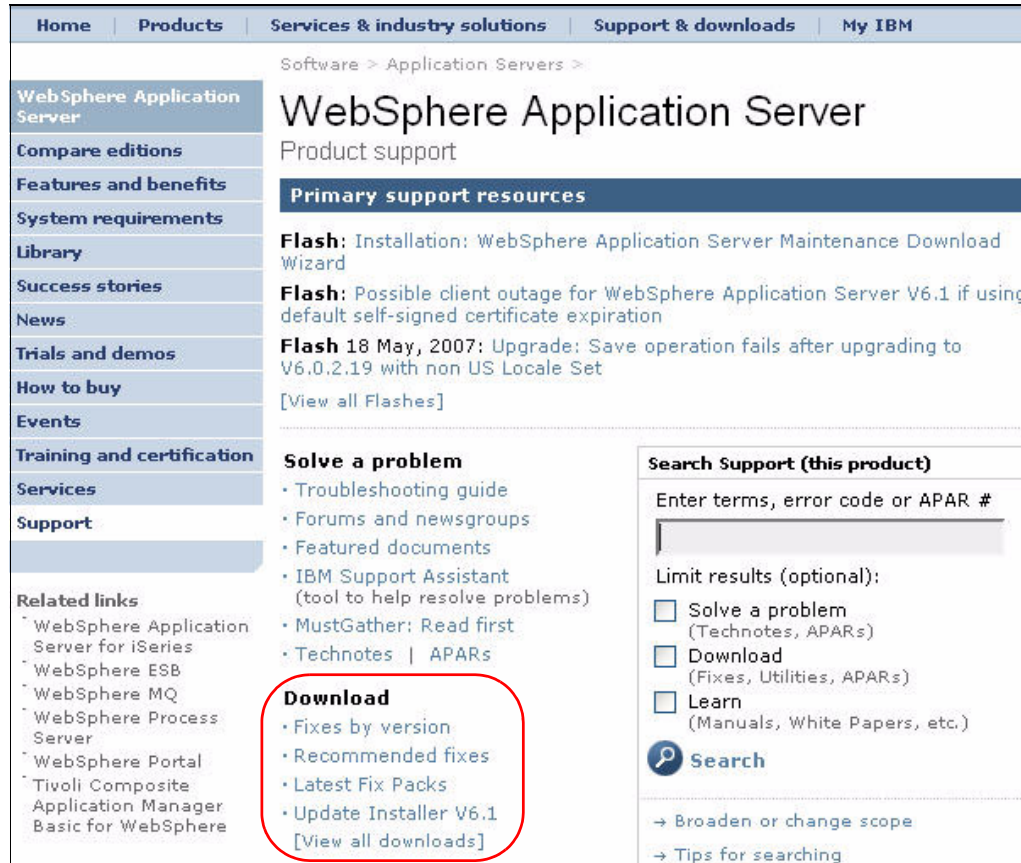

Figure B-1 WebSphere Application Server Support Web site

In the Download section of the page (highlighted in Figure B-1), there is a direct link to the latest fix packs for WebSphere Application Server. You can also display all available fixes grouped by version.

**Important:** We recommend that you install a fix pack by installing the latest level of WebSphere Application Server group PTF. The group PTF includes the fix pack and group PTFs for the related products. There might be WebSphere Application Server dependencies on the other products, such as HTTP Server and Java.

If you open the Web page for a fix, it looks similar to Figure B-2 on page 415. The fix document has a problem description, installation instructions, and the download link for the fix itself. One of the most important sections on this page is the document information bar (circled in Figure B-2 on page 415). It provides information about the applicable operating systems and WebSphere Application Server fix level to which you can apply the current fix.

## PK27906; 6.1: invalidcontenttypeexception when submitting multipart request

### Downloadable files

#### Abstract

In a FIM portlet have a DiskFileUpload parseRequest() and this method throws a FileUploadBase\$InvalidContentTypeExcept

#### Download Description

PK27906 resolves the following problem:

#### ERROR DESCRIPTION:

NPE when submitting through multipart request. This APAR is for defect in isclite.jar

#### LOCAL FIX:

#### PROBLEM SUMMARY

#### USERS AFFECTED:

WebSphere® Application Server version 6.1 users having multipart/form-data in request.

#### PROBLEM DESCRIPTION:

In a FIM portlet have a DiskFileUpload parseRequest() and this method throws a FileUploadBase\$InvalidContentTypeExcept

#### RECOMMENDATION:

None

We are defaulting to a content type of text/html, thus you will experience an exception if passing in anything other than that from your portlet.

#### PROBLEM CONCLUSION:

We need to parse the content type value from the header that the portlet has defined. ContentTypeProvider.class in the isclite.jar has been updated to handle this.

The fix for this APAR is currently targeted for inclusion in fixpack 6.1.0.2.

Please refer to the recommended updates page for delivery information:

<http://www.ibm.com/support/docview.wss?rs=180&uid=swq27004980>

### Document information

Product categories:

**Software**

**Application Servers**

**Distributed  
Application & Web  
Servers**

**WebSphere  
Application Server**

**Administrative  
Console (all  
non-scripting)**

Operating system(s):

**AIX, HP-UX, Linux,  
Linux Red Hat -  
pSeries, Linux  
pSeries, Linux  
zSeries, OS/390,  
OS/400, Solaris,  
Windows, i5/OS,  
z/OS**

Software version:

**6.1**

Software edition:

**Base, Express,  
Network  
Deployment**

Reference #:

**4013096**

IBM Group:

**Software Group**

Figure B-2 A Fix page

**Important:** Read the information about prerequisites in the download page before you install the fix pack. Sometimes there are prerequisite and co-requisite PTFs that you must also install.

A fix comes supplied in a file with the extension .pak. Download the fix file, and place it in the maintenance directory of Update Installer, for example:

```
/qibm/proddata/websphere/UpdateInstaller/v61/updi/maintenance
```

The installation procedure is identical to the fix pack installation (see 3.6.1, "Installing the WebSphere Group PTF" on page 53), but you need to specify one additional argument when you run the *update* script:

```
update -W product.location=<installLocation> -W  
maintenance.package="maintenance/<fix name>"
```

Example: (We split the command into three lines for clarity):

```
update  
-W product.location=/QIBM/ProdData/WebSphere/AppServer/V61/Base/  
-W maintenance.package="maintenance/6.1.0.0-WS-WAS-IFPK27906.pak"
```

## Uninstalling fixes

On rare occasions you may encounter a situation where after applying a WebSphere Application Server fix, you start seeing undesirable behavior in WebSphere Application Server. It could be:

- ▶ A fix that changes WebSphere Application Server behavior, and this change exaggerates a preexisting application problem
- ▶ A defective fix

Update Installer provides a way for removing a fix, if required:

1. Start a 5250 emulator session, and sign on.
2. Start QShell:

```
STRQSH
```

3. Switch to the Update Installer directory, for example:

```
/qibm/proddata/websphere/updateinstaller/v61/updi
```

4. Run the update script. There are two ways to execute this script to uninstall a fix:
  - If you want to uninstall the last fix or fix pack that was installed, run the following command, Where `<WebSphere_install_root>` is the directory where WebSphere Application Server is installed:

```
update -W product.location="<WebSphere_install_root>"  
       -W update.type="uninstall"
```

Example:

```
update -W product.location="/QIBM/ProdData/WebSphere/AppServer/V61/Base"  
       -W update.type="uninstall"
```

- If you need to uninstall a specific fix or fix pack, then you need to provide the name of the backup file:

```
update -W backup.package="<backup_file_name>"  
       -W product.location="<WebSphere_install_root>"  
       -W update.type="uninstall"
```

Example:

```
update -W backup.package="6.1.0.0-WS-WAS-IFPK27906.pak"  
       -W product.location="/QIBM/ProdData/WebSphere/AppServer/V61/Base"  
       -W update.type="uninstall"
```

## The historyInfo script

To determine the backup file name, you need to run the historyInfo script, which you can find in the /bin directory of your WebSphere Application Server installation. The following two commands are the example of how to run the script:

```
cd /qibm/proddata/websphere/appserver/v61/base/bin  
historyInfo -file /tmp/history.txt
```

In our example, we direct output of the script to the /tmp/history.txt file. Open the generated file to see the history of WebSphere updates. All updates are sorted by update time and date with the latest update listed last. You can copy the pak file name and use it for uninstalling a fix. Example B-1 on page 417 shows a sample output of the historyInfo script.

*Example: B-1*

---

Installation Event

-----  
Maintenance Package ID 6.1.0.0-WAS-WAS-IFPK27906  
Action install  
Package Filename 6.1.0.0-WAS-WAS-IFPK27906.pak  
Log File Name  
/QIBM/ProdData/WebSphere/AppServer/V61/Base/logs/update/6.1.0.0-WAS-WAS-IFPK27906.install/updatelog.txt  
Timestamp 2006-10-02 13:53:45-0500  
Result success

Component Installation Event

-----  
Maintenance Package ID 6.1.0.0-WAS-WAS-IFPK27906  
Component Name webui  
Action install  
Update Action replace  
Timestamp 2006-10-02 13:53:45-0500  
Result success

Installation Event

-----  
Maintenance Package ID 6.1.0.0-WAS-WAS-IFPK27906  
Action uninstall  
Package Filename **6.1.0.0-WAS-WAS-IFPK27906.pak**  
Log File Name  
/QIBM/ProdData/WebSphere/AppServer/V61/Base/logs/update/6.1.0.0-WAS-WAS-IFPK27906.uninstall/updatelog.txt  
Backup File Name not applicable  
Timestamp 2006-10-02 17:08:32-0500  
Result success

Component Installation Event

-----  
Maintenance Package ID 6.1.0.0-WAS-WAS-IFPK27906  
Component Name webui  
Action uninstall  
Update Action replace  
Timestamp 2006-10-02 17:08:32-0500  
Result success

---

## Verifying the fix level

Sometimes you need to verify the fix level of your WebSphere Application Server installation. We describe two ways to determine this information.

The first is to use Web Administration for i5/OS. You can access this interface in a Web browser at the following URL:

http://<System\_i\_name>:2001

In the URL, <System\_i\_name> is the host name of your server, and 2001 is the default port:

1. Sign in, and click the **IBM Web Administration for i5/OS** link.
2. Select the **Mange** tab, and click **All Servers** at the top of the page. A new page displays.
3. Select the **All Application Servers** (Figure B-3 on page 418) tab. The page should show all WebSphere Application Server profiles and corresponding fix levels.

**Manage All Servers** ?

All HTTP Servers | All Application Servers | All ASF Tomcat Servers

Data current as of Oct 2, 2006 1:50:25 PM.

Server ▲	Version	Status	Address:Port
<input type="radio"/> <a href="#">App01/App01</a>	6.1.0.1 Base	Stopped	*:20000,20001,20002,20003,20004,20005
<input type="radio"/> <a href="#">App02/App02</a>	6.1.0.1 Base	Stopped	*:21000,21001,21002,21003,21004,21005
<input type="radio"/> <a href="#">App03/App03</a>	6.1.0.1 Base	Stopped	*:22000,22001,22002,22003,22004,22005
<input type="radio"/> <a href="#">avn01/avn01</a>	6.1.0.1 Base	Stopped	*:55101,55102,55103,55104,55105,55106
<input type="radio"/> <a href="#">default/server1</a>	6.1.0.1 Base	Stopped	*:2809,8880,9043,9060,9080,9443
<input type="radio"/> <a href="#">j9res_GW/j9res_GW</a>	6.1.0.1 Base	Running	*:59901,59902,59903,59904,59905,59906
<input type="radio"/> <a href="#">nbsvr01/nbsvr01</a>	6.1.0.1 Base	Stopped	*:51001,51002,51003,51004,51005,51006
<input type="radio"/> <a href="#">PSS61SVR/PSS61SVR</a>	6.1.0.1 Base	Running	*:6551,6552,6553,6554,6555,6556
<input type="radio"/> <a href="#">Raf01/RafSvr</a>	6.1.0.1 Base	Stopped	*:2812,8881,9044,9061,9081,9444
<input type="radio"/> <a href="#">SYSINST/ADMIN</a>	6.0.2.11	Running	*:4621,4625,4629,4630,4631,4632
<input checked="" type="radio"/> <a href="#">test32JVM/test32JVM</a>	6.1.0.1 Base	Running	*:10023,10024,10025,10026,10027,10028
<input type="radio"/> <a href="#">WAS60SVR/WAS60SVR</a>	6.0.2.11	Running	*:10008,10009,10010,10011,10012,10013
<input type="radio"/> <a href="#">WAS60SVR01/WAS60SVR01</a>	6.0.2.11	Stopped	*:61001,61002,61003,61004,61005,61006
<input type="radio"/> <a href="#">WAS61_ADAM1/WAS61_ADAM1</a>	6.1.0.1 Base	Running	*:11100,11101,11102,11103,11104,11105
<input type="radio"/> <a href="#">WAS61_ADAM2/WAS61_ADAM2</a>	6.1.0.1 Base	Stopped	*:11200,11201,11202,11203,11204,11205
<input type="radio"/> <a href="#">WAS61_ADAM3/WAS61_ADAM3</a>	6.1.0.1 Base	Stopped	*:11300,11301,11302,11303,11304,11305
<input type="radio"/> <a href="#">WAS61_ADAM4/WAS61_ADAM4</a>	6.1.0.1 Base	Stopped	*:11400,11401,11402,11403,11404,11405
<input type="radio"/> <a href="#">wasssl/wasssl</a>	6.1.0.1 Base	Stopped	*:52400,52401,52402,52403,52404,52405

Figure B-3 Viewing the fix level

The second way is more complex, but it provides more detailed information about the fix level. There is a script, called *versionInfo*, that can provide this information in several formats:

- ▶ In a text or HTML format
- ▶ In a 5250 emulator window or a file

The script is located in the bin directory of your WebSphere Application Server installation, for example:

```
/qibm/proddata/websphere/appserver/v61/base/bin
```

The command syntax is:

```
versionInfo [ -format text | html ]
             [ -file file_name ]
             [ -long ]
             [ -maintenancePackages ]
             [ -maintenancePackageDetail ]
             [ -components ]
             [ -componentDetail ]
```

Table B-1 explains the parameters.

Table B-1 *versionInfo* Script parameters

Parameter	Comments
-components	Adds a list of installed components to the report.

Parameter	Comments
-componentDetail	Adds details about installed components to the report.
-file file_name	Specifies the output file name. The report goes to standard output (stdout) by default.
-format text   html	Selects the format of the report. The default is text.
-long	Creates the long version of the report.
-maintenancePackages	Adds a list of applied maintenance packages to the report.
-maintenancePackageDetail	Adds details about an applied maintenance package to the report.

If you do not specify any parameters, the script shows information similar to Example B-2 in a 5250 window.

*Example: B-2 versionInfo output*

```

-----
IBM WebSphere Application Server Product Installation Status Report
-----

Report at date and time October 2, 2006 1:06:27 PM CDT

Installation
-----
Product Directory      /QIBM/ProdData/WebSphere/AppServer/V61/Base
Version Directory     /QIBM/ProdData/WebSphere/AppServer/V61/Base/properties/version
DTD Directory         /QIBM/ProdData/WebSphere/AppServer/V61/Base/properties/version/dtd
Log Directory         /QIBM/ProdData/WebSphere/AppServer/V61/Base/logs
Backup Directory      /QIBM/ProdData/WebSphere/AppServer/V61/Base/properties/version/nif/backup
TMP Directory         /tmp

Product List
-----
BASE                  installed

Installed Product
-----
Name                  IBM WebSphere Application Server
Version               6.1.0.1
ID                    BASE
Build Level           cf10631.18
Build Date            8/3/06

-----
End Installation Status Report
-----

```

Here is another example:

```
versionInfo -file /tmp/versionInfo.html -format html -maintenancePackages
```

This command creates an HTML file with product and maintenance package information. You can open the generated file in a Web browser.





# IBM Support Assistant

In this appendix, we discuss *IBM Support Assistant (ISA)* version 3.0.1. ISA is a free, local serviceability workbench that helps you resolve questions and problems with IBM software products. A main goal of ISA is to become a single conduit for IBM customers to retrieve and use serviceability tooling and also to provide the core foundation of functions required for self-help. Its features include serviceability tools, concurrent searching, quick access to support-related information, and electronic problem management, including automated data collection. All of these functions are delivered together in the IBM Support Assistant application to better enable users for self-help problem determination.

The focus of this appendix is to demonstrate the typical tasks for downloading, installing, and using the tool. For more information, visit the ISA Web site at:

<http://www.ibm.com/software/support/isa>

# Overview of IBM Support Assistant

IBM Support Assistant is a free software product intended to help IBM customers to be more productive with IBM products by resolving problems faster.

**Important:** ISA is the strategic delivery mechanism for IBM Java virtual machine (JVM) tools.

You can use ISA when experiencing a problem. ISA offers resources for self-help that can enable you to identify, assess, and overcome questions or problems without having to contact IBM. When it is necessary to contact IBM, ISA offers resources for fast submission of problem reports and immediate, automated collection of diagnostic data that can accelerate problem resolution.

## Installing IBM Support Assistant

ISA 3.0.1 is available as a free download from the following Web site:

<http://www.ibm.com/software/support/isa/>

Updates to the ISA application are delivered through the Updater function within ISA (refer to the documentation delivered with the product).

## Prerequisites

The following list describes the operating systems that ISA supports:

- ▶ Microsoft® Windows XP SP1, 2000, and 2003 server
- ▶ Linux RedHat Advanced Server 3, Linux SuSE 9.0
- ▶ HP/UX 11
- ▶ Solaris™ 9
- ▶ AIX 5.2 and 5.3

Table C-1 contains the Web browsers that ISA supports.

*Table C-1 Supported Web browsers*

Platform	Web browser
Windows	Microsoft Internet Explorer 6.x
UNIX	Mozilla 1.7 and later Mozilla Firefox 1.0.7+
Linux	Mozilla 1.7 and later Mozilla Firefox 1.0.7+

ISA, along with the tools that we describe in this IBM Redbook, requires a minimum of 200 MB of free space for installation.

You can use ISA with i5/OS to gather product information, run problem determination tools, and analyze problems, but you must install ISA on a supported workstation that you can connect to your i5/OS. We also recommend that you set up an integrated file system share to easily access i5/OS files from your workstation.

## Downloading IBM Support Assistant from the Web

There are two major components to downloading ISA from the Web. You must first download the product itself. Then, you must run the Updater program in ISA to download any tools or features for products that you are interested in.

The following steps document how to download ISA to the Windows platform. Modify the steps as required for your operating system:

1. Open the following URL in your Web browser:  
<https://www14.software.ibm.com/webapp/iwm/web/preLogin.do?source=isa>
2. Click **Sign in** to sign in to the Web site using your IBM ID and password. If you do not have one, register by clicking the **register now** link.
3. Select the latest version for your operating system (Figure C-1), and click **Continue**.



Figure C-1 Selecting the ISA version

4. You may be presented with your profile information. If needed, make any changes, and click **Submit**.
5. On the next page, select the components that you want to download, and click **Download now** (we used the Download Director method).

The new Download Director window opens, and you should see the download progress.

6. When the download of the zip file completes, extract the zip files, using a zip compression utility (PKZIP, WinZip, or InfoZip), to a temporary directory, for example C:\Downloads\isa\_v3 (we use a Windows workstation for installation).

**Note:** Do not extract the files into a directory name that contains spaces.

7. After it is extracted, run the executable file (setupwin32.exe) to start the installation.

**Note:** There is a way to install ISA using console or silent mode, but GUI installation is the easiest way for installing ISA.

Refer to the following Web page for detailed information about silent installation in the unzipped folder:

```
<installation_dir>\Installation_and_Troubleshooting_Guide\en\Installation_and_Troubleshooting_Guide.html
```

8. Click **Next** to install ISA to your workstation.
9. Specify an installation directory, and click **Next**.
10. Select the features for ISA that you want to install, and click **Next**.
11. View and accept the license agreement, and click **Next**.
12. Review the Summary panel, and click **Install**.
13. When the installation completes successfully, click **Finish**.
14. You must now configure ISA to work with one of the available tools or features. Refer to “Configuring and updating IBM Support Assistant” on page 424.

## Configuring and updating IBM Support Assistant

After you successfully install ISA, you must also download one or more features for the products that you want to use. In our example, we have to install WebSphere Application Server V6.1 features to access available JVM tools.

To install a WebSphere Application Server feature:

1. Start ISA. Refer to “Starting IBM Support Assistant” on page 427 for more information.
2. Click **Updater**.
3. Click the **New Plug-ins** tab, as shown in Figure C-2 on page 425.
4. The plug-in features are categorized by product family. Expand **WebSphere**, and select **WebSphere Application Server V6.1**, as shown in Figure C-2 on page 425.

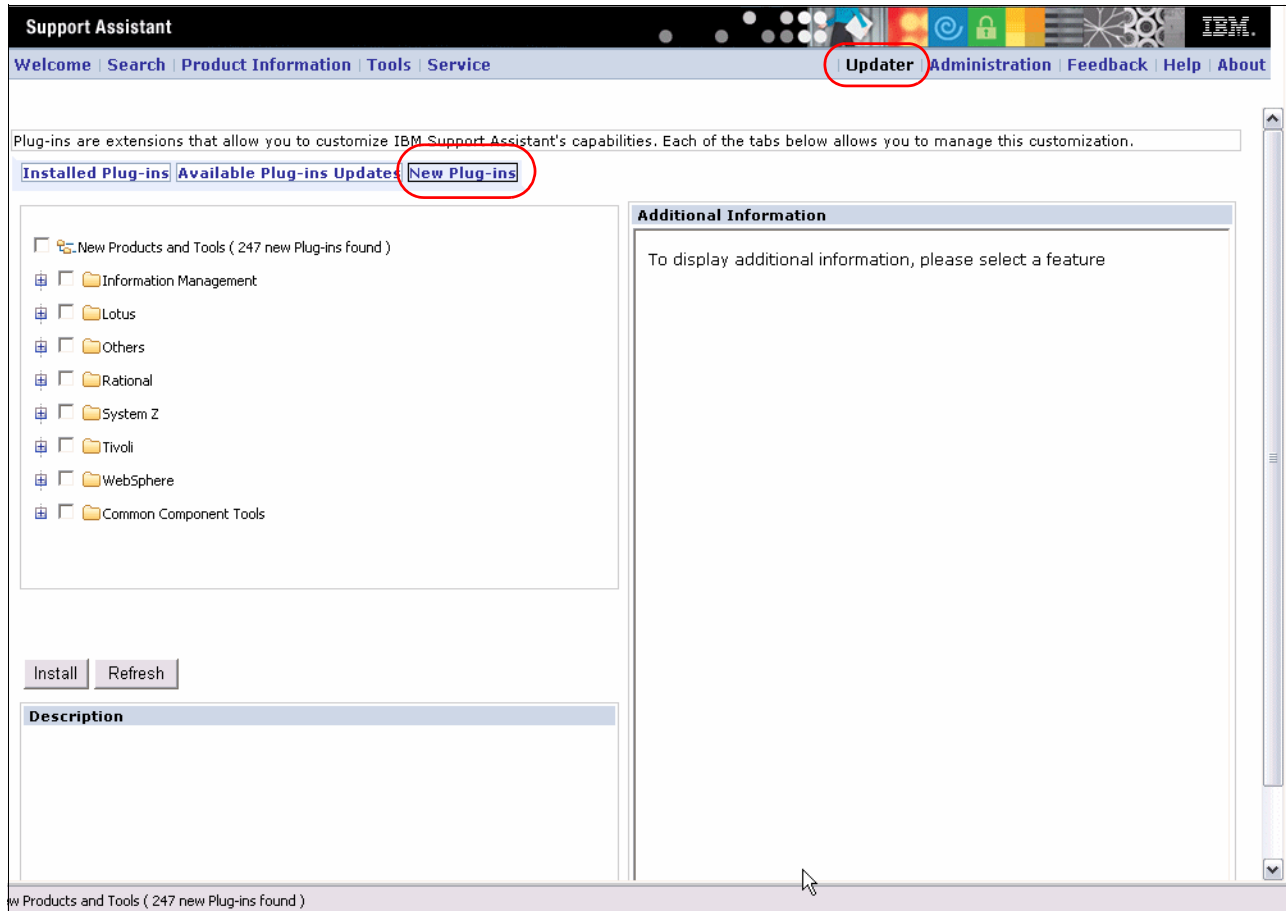

Figure C-2 Installing WebSphere Application Server 6.1 feature

### Adding the JVM tools

Next you add the JVM tools:

1. Scroll down the list of available features, and expand **Common Component Tools** as shown in Figure C-3 on page 426.
2. Select a check box next to the tools that you want to install, and click **Install**.

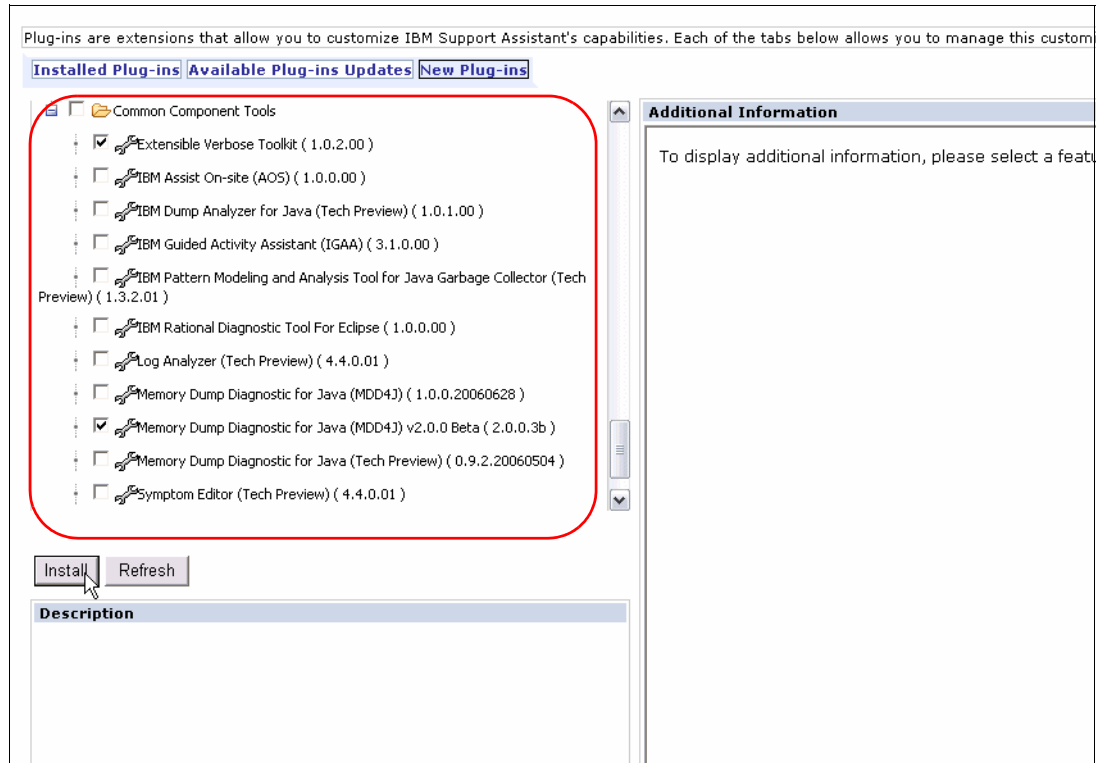

Figure C-3 Adding the JVM tools

3. A new pop-up window is displayed. Be sure to read the license and description for each feature and tool. If you agree with the license, click **I agree**.
4. The installation starts. When all selected tools and features are installed, a window opens. Click **OK** to restart ISA.

Keeping ISA current is critical to your success in finding the most value out of the ISA tool. Often times, new tools or features are released on an intermittent basis.

**Important:** It is important to occasionally check for new updates for the installed tools or to see what other tools for your products were made available since your installation or last update. You can also check information about the Available Plug-ins Updates tab (see Figure C-2 on page 425).

## Uninstalling IBM Support Assistant

You can uninstall ISA in several ways:

- ▶ (Windows only) Use the Add/Remove Programs task in the control panel to remove the IBM Support Assistant product.
- ▶ (Windows only) Navigate to **Start** → **Programs** → **IBM Support Assistant and Electronic Service Agent™** → **Uninstall IBM Support Assistant and Electronic Service Agent** to start the uninstallation process.
- ▶ (All platforms) Navigate to your ISA install location, double-click the `_uninst` folder, and run the uninstall executable file. The default location is:

```
c:\Program Files\IBM\IBM Support Assistant v3\_uninst\uninstaller.exe
```

**Note:** You can also uninstall ISA in the console or silent mode. Run the following command from a command prompt:

```
<install_root>\_uninst\<uninstaller_executable_file> -console
```

Or:

```
<install_root>\_uninst\<uninstaller_executable_file> -silent -options  
options.txt
```

Example, in Windows:

```
"c:\Program Files\IBM\IBM Support Assistant v3\_uninst\uninstall.exe"  
-console
```

## Using IBM Support Assistant

Use ISA to search for support information, find product information, analyze product problems using specialized tools, and submit problem reports to IBM that are expedited with automatic data collection.

You can also use the ISA interface to check for new IBM products and tools that are developed for use with ISA.

## Starting IBM Support Assistant

On the Windows platforms, ISA starts up with its own GUI windows. On all other platforms, ISA launches the default browser for the system, and you access the ISA application using the browser interface.

To start ISA on Windows, click **Start** → **All Programs** → **IBM Support Assistant and Electronic Service Agent** → **IBM Support Assistant V3.1**.

To start ISA on other supported platforms:

1. Open the command prompt.
2. Specify `startisa.sh` on the command line. A Mozilla browser opens with the IBM Support Assistant V3.1 Welcome page.

**Note:** If you do not have the Mozilla browser installed, you have to manually open the ISA URL in another supported Web browser. The URL that is used to access ISA is also written to the console window where you ran the `startisa.sh` script. The URL is also listed in the `<install_root>/workspace/logs/isauri.log` file. Open this file, copy the URL, and paste it in a Web browser window.

## Starting JVM tools

To access any JVM tool, you have to open the WebSphere Application Server V6.1 feature. Use the following instructions to start a JVM tool:

1. In the ISA window, click **Tools** in the toolbar.

2. In the left menu, click **WebSphere Application Server 6.1**. You must see the list of the installed tools in the right frame, as shown in Figure C-4.

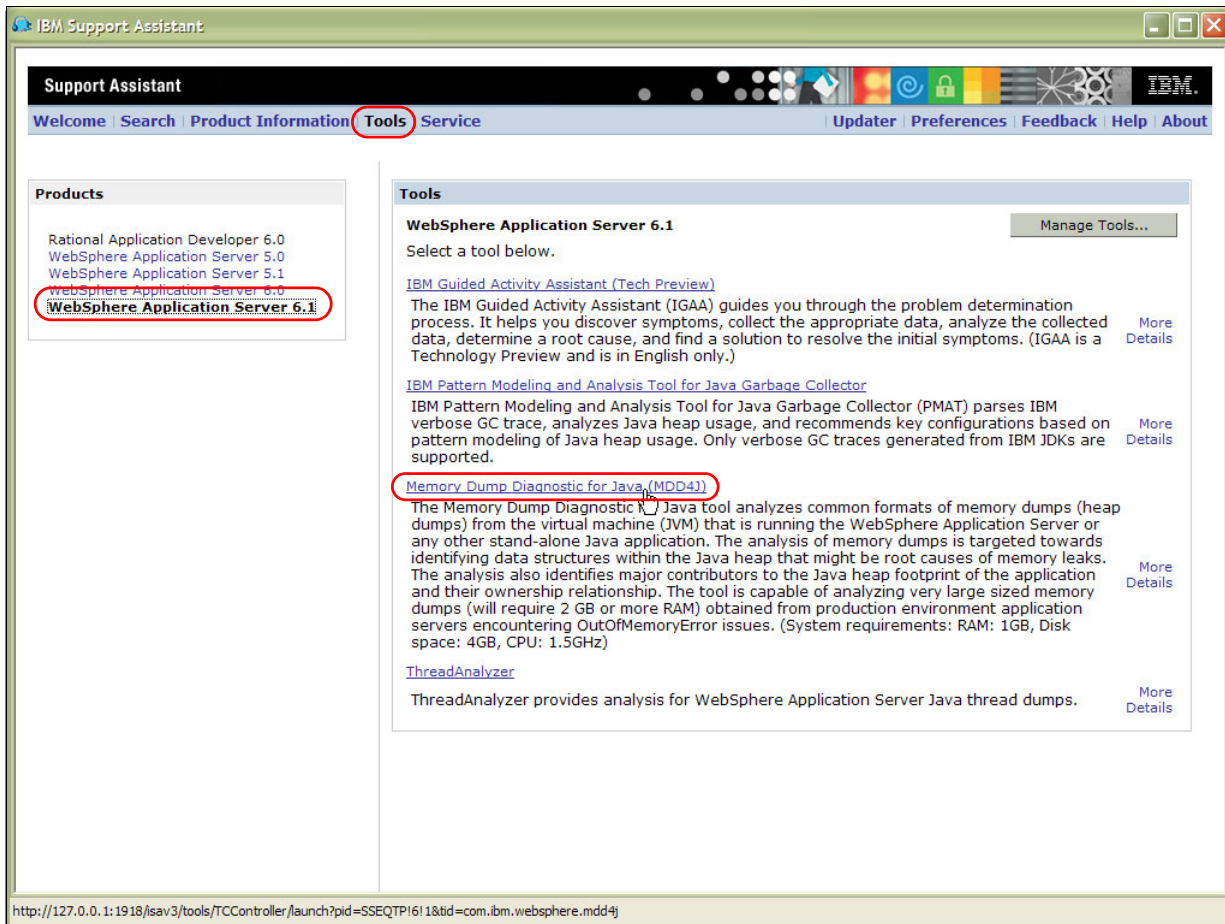

Figure C-4 Available JVM tools

3. Click a link for a desirable tool. In our example, we click **Memory Dump Diagnostic for Java (MDD4J)**. If you see any warning message, read its text, and click OK. Some tools have prerequisites.

A new window opens. Now you can use the tool. Refer to 9.4.6, “Memory Dump Diagnostic for Java (MDD4J)” on page 328 for the instructions about how to use this tool.

## Searching for WebSphere Application Server support information

Before you can search for WebSphere Application Server support information, make sure that you configured ISA with the appropriate WebSphere Application Server features. See “Configuring and updating IBM Support Assistant” on page 424 for more information.

ISA allows you to access support information in multiple locations. You can search these types of support documents and Web sites:

- ▶ IBM software support documents
- ▶ IBM developerWorks®
- ▶ IBM newsgroups and forums
- ▶ IBM product information centers
- ▶ Google

To access WebSphere Application Server support information using ISA, perform the following steps:

1. Start ISA. See “Starting IBM Support Assistant” on page 427 for more information.
2. Click **Search**.
3. Enter your search criteria in the text box, select what support locations you want to search, and click **Search**.
4. Matching search criteria appears in the Search results panel. Click any link to go to that support document's Web site.

## Searching for WebSphere Application Server product Web sites

Before you can search for WebSphere Application Server product information, make sure that you configured ISA with the appropriate WebSphere Application Server features. See “Configuring and updating IBM Support Assistant” on page 424 for more information.

To access WebSphere Application Server product information using ISA:

1. Start ISA. See “Starting IBM Support Assistant” on page 427 for more information.
2. Click **Product Information**.
3. In the Products panel, click the WebSphere Application Server product.
4. Available WebSphere Application Server product Web sites appear in the Product Information panel. Click any link to go to that product's Web site.

## Submitting a problem report to IBM

ISA provides a service feature with an automated system and symptom-based collector. The system collector gathers general information from your operating system, registry, and so on. The symptom-based collection provides the unique ability to collect specific information relating to a particular problem that you are having. It can also provide you with the ability to automatically enable tracing that is helpful to IBM support as part of the data gathering process.

You also can submit problems directly to IBM by creating a problem report and attaching a generated collector file at the same time.

**Note:** You must use the Portable Collector option to export a .jar file to your i5/OS. The option for Collect Data is not supported on i5/OS.

Perform the following steps to collect data from your i5/OS and submit a problem report with the collected data:

1. Start ISA. Refer to “Starting IBM Support Assistant” on page 427 for more information.
2. Click **Service**.
3. Click **Create Portable Collector**.
4. In the Select a product box, select **System collector**.
5. Enter the integrated file system path to your i5/OS in the Output directory field, for example:

U:\home\collector\_output

In the example, U: is a mapped network drive to your system's Integrated File System (IFS) share.

6. Enter the name of the .jar file to be created in the Output file name (\*.jar) field. You must enter the .jar extension, for example:  
     problem.jar
7. Click **Export**, as shown in Figure C-5.

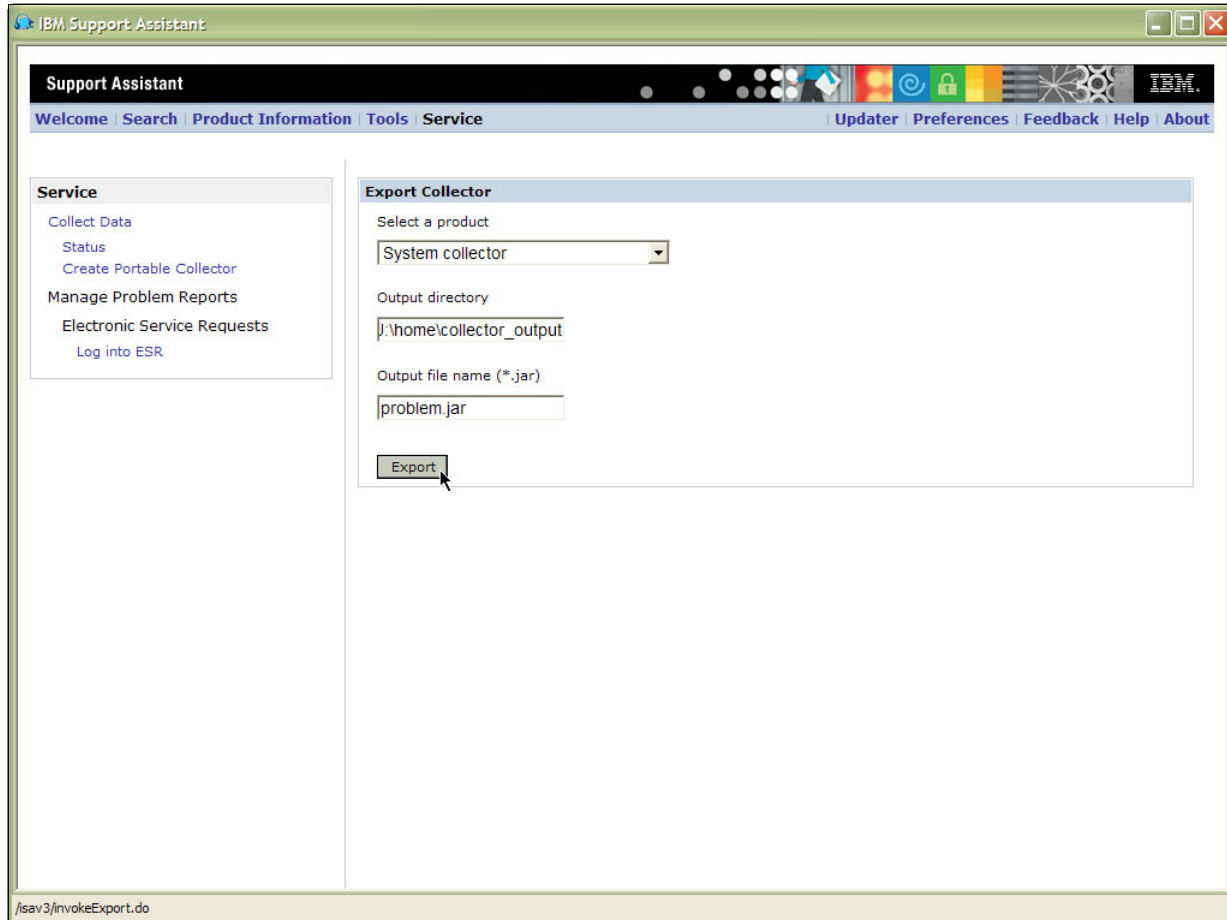

Figure C-5 Creating a portable collector

8. Open an IBM Personal Communications window, and log in to your system.
9. Enter STRQSH on the CL command line, and press Enter.
10. On the QShell command line, enter the change directory command to change to your .jar file location, for example:  
     cd /home/collector\_output
11. Enter the **jar -xvf problem.jar** command on the Qshell command line. Files are extracted to your directory location.
12. Enter ENV on the Qshell command line to check whether you have a JAVA\_HOME variable defined. ISA works best with Java Development Kit (JDK) 1.4 on i5/OS.
13. If you do not have a JAVA\_HOME variable defined, enter the following command on the Qshell command line:  
     export JAVA\_HOME=/QIBM/ProdData/Java400/JDK14  
     You can verify the JAVA\_HOME variable value by running the **java -version** command on the Qshell command line.

14. Enter `chmod -R 755 `find . -name '*.sh'`` on the Qshell command line to make sure that your Qshell scripts have execute permission.
15. Enter `./startcollector_iseries.sh` on the Qshell command line to begin system data collection.
16. At the prompt, enter an output file name and path for the newly-created ZIP file, for example:  

```
/home/collector_output/12345.724.888.problemoutput.zip
```
17. Enter yes, and press Enter to create the file.
18. Enter 1 at the prompt to collect system output for WebSphere Application Server.
19. The tool shows you several options to choose from. Type the option's number, and press Enter.
20. The tool may offer you more options to choose from. Select a desired option(s) to continue. When the tool finishes, you should see a command prompt.
21. Go back to ISA, and click **Log into ESR**.
22. Enter your IBM ID, Password, IBM customer number, and Country/region of support contract, and click **Login**.
23. On the Submit Problem Report window, identify your product, select your component, select your contract, provide your relevant information, and attach the ZIP file that was created with the Portable collector tool.

## Troubleshooting IBM Support Assistant

There are several log files available in ISA to help with troubleshooting ISA problems.

There is an installation and uninstallation log file that is available in the location where ISA is installed. The file name is log.txt.

For problems with starting ISA, there are log files that are available in the `<install_root>/workspace/logs` directory. The `isa_*.log` files represent a set of rolling log files, where the most recent log file is always named `isa_0.log`.

There is also a log file in the `<install_root>/workspace/.metadata` directory that contains logging messages that might occur either before ISA logging is initialized or if logging initialization fails.

Refer to the following file for some troubleshooting information:

```
<ISA_installation_files_dir>\Installation_and_Troubleshooting_Guide\en\Installation_and_Troubleshooting_Guide_en.html
```

This file is part of the directory that is created when you expand the ZIP file that you download from the Web. Refer to "Downloading IBM Support Assistant from the Web" on page 423.





# D

## **Data to collect before you contact IBM Support**

In this appendix, we discuss helpful commands and tools that you should run before you contact IBM support.

If you have a problem with your System i server, often times there are a set of common commands and tools that you can run before you contact IBM support. Obtaining information, which IBM support needs, beforehand can save you time in getting a problem resolution.

## System commands

We recommend that you run several system commands, send the output from these commands to a spooled file, and copy these files to your desktop. These files are helpful for IBM support to understand the type of environment on which your i5/OS is running.

1. Run the following commands:

a. Display Program Temporary Fix (DSPPTF)

The DSPPTF command shows the program temporary fixes (PTFs) for a specified product. Enter this command on the CL command line:

```
DSPPTF LICPGM(*ALL) OUTPUT(*PRINT)
```

b. Work with PTF Group (WRKPTFGRP)

The WRKPTFGRP command displays a list of PTF groups on the system. A PTF group consists of a list of program temporary fixes (PTFs) that are defined for the purpose of managing those PTFs as one group. Enter this command on the CL command line:

```
WRKPTFGRP PTFGRP(*ALL)
```

c. Work with System Values (WRKSYSVAL)

The WRKSYSVAL command allows you to work with a specified system value. The system values are provided as part of the system. Enter this command on the CL command line:

```
WRKSYSVAL SYSVAL(*ALL) OUTPUT(*PRINT)
```

d. Display Software Resources (DSPSFWRSC)

The DSPSFWRSC command allows you to show, print, or write to an output file the list of installed software resources. Enter this command on the CL command line:

```
DSPSFWRSC OUTPUT(*PRINT)
```

e. Configure TCP/IP (CFGTCP)

The CFGTCP command displays a menu that allows you to define or change the TCP/IP configuration. We recommend that you run options 1, 10, and 12. Press F6 to print a list for each option.

2. Use iSeries Navigator to copy the output from the above commands from your i5/OS to your desktop:

a. Open iSeries Navigator, and sign on to your i5/OS.

b. Expand **Basic Operations**, and click **Printer Output**.

c. The spooled files from step b should be visible in the right panel. Right-click the files that you want to copy to your desktop, and click **Export**.

d. Navigate to the location on your desktop where you want to save the files, and click **Save**.

## WebSphere Application Server files

The following WebSphere Application Server files are helpful to check version levels and error logs of your product installation:

- ▶ WAS.product

This file is found in:

<WAS\_install\_root>/properties/version

The Base edition installed in the default directory:

/QIBM/ProdData/WebSphere/AppServer/V61/Base/properties/version

- ▶ logs.zip

Use a zip compression utility to zip the

/QIBM/ProdData/WebSphere/AppServer/V61/Base/logs directory. You may have a different default install root path, depending on your installation parameters.

- ▶ profile\_log.zip

Use a zip compression utility to zip the

/QIBM/UserData/WebSphere/AppServer/V61/Base/profiles/instance\_name/log directory for each profile in question. You may have a different user profile root path, depending on your installation parameters.

## WebSphere Application Server tools

There are several tools and utilities that you can run to help IBM support with problem determination:

- ▶ IPTest

The IPTest Java utility is shipped with the WebSphere Application Server product. You can use it to debug TCP/IP configuration problems. To run this utility:

1. Run the iptest QShell script that is located in the /QIBM/ProdData/WebSphere/AppServer/V61/Base/bin directory for the default installation directory. The script's output is similar to Example D-1:

*Example: D-1 Example output of the IPTest utility*

---

```
Local Address: 12.34.56.78
Local Name: MYSYSTEM.MYCOMPANY.COM
All addresses for MYSYSTEM.MYCOMPANY.COM:
12.34.56.78
```

---

2. The Local Address is the IP address for your i5/OS. This value must not be blank. The Local Name is the domain-qualified host name for your i5/OS. Press F3 to exit.

If you see exception as an output, your TCP/IP configuration is incorrect.

- ▶ Collector tool

The Collector tool gathers extensive information about your WebSphere Application Server installation and packages it in a .jar file that you can send to IBM support to assist in determining and analyzing your problem. Information in the .jar file includes logs, property files, configuration files, operating system and Java data, and the absence or level of each software prerequisite.

The collector program runs to completion despite any errors that it might find. Errors might include missing files or commands. The Collector tool collects as much data in the .jar file as possible.

Run the collector tool from the Qshell command line, for example:

```
/QIBM/ProdData/WebSphere/AppServer/V61/Base/bin/collector -profileName  
<profile_name>
```

Two files are created in the current directory: Collector.log file and an output JAR file. The name of the JAR file is composed of the host name, cell name, node name, and profile name.

## Working with trace

You can set up a trace to get detailed information about running the WebSphere Application Server components, including application servers, clients, and other processes in your environment.

The diagnostic trace configuration settings for a server process determines the initial trace state for a server process. The configuration settings are read at server startup and used to configure the trace service. You can also change many of the trace service properties or settings while the server process is running. To set up a trace:

1. Start the WebSphere Administrative Console.
2. In the console Navigation tree, click **Troubleshooting** → **Logs and Trace**.
3. Click your server name, and then click the **Diagnostic Trace** link.
4. Click the **Configuration** tab (Figure D-1 on page 437).
5. Select the **Enable Log** check box to enable trace, and clear the check box to disable trace.
6. Select whether to direct trace output to either a file or an in-memory circular buffer.
7. If you select the in-memory circular buffer for the trace output, set the size of the buffer, specified in thousands of entries. This is the maximum number of entries that are retained in the buffer at any given time.
8. If you select a file for trace output, set the maximum size in megabytes to which the file should be allowed to grow. When the file reaches this size, the existing file is closed, renamed, and a new file with the original name reopened. The new name of the file is based on the original name with a time stamp qualifier added to the name. In addition, specify the number of history files to keep.

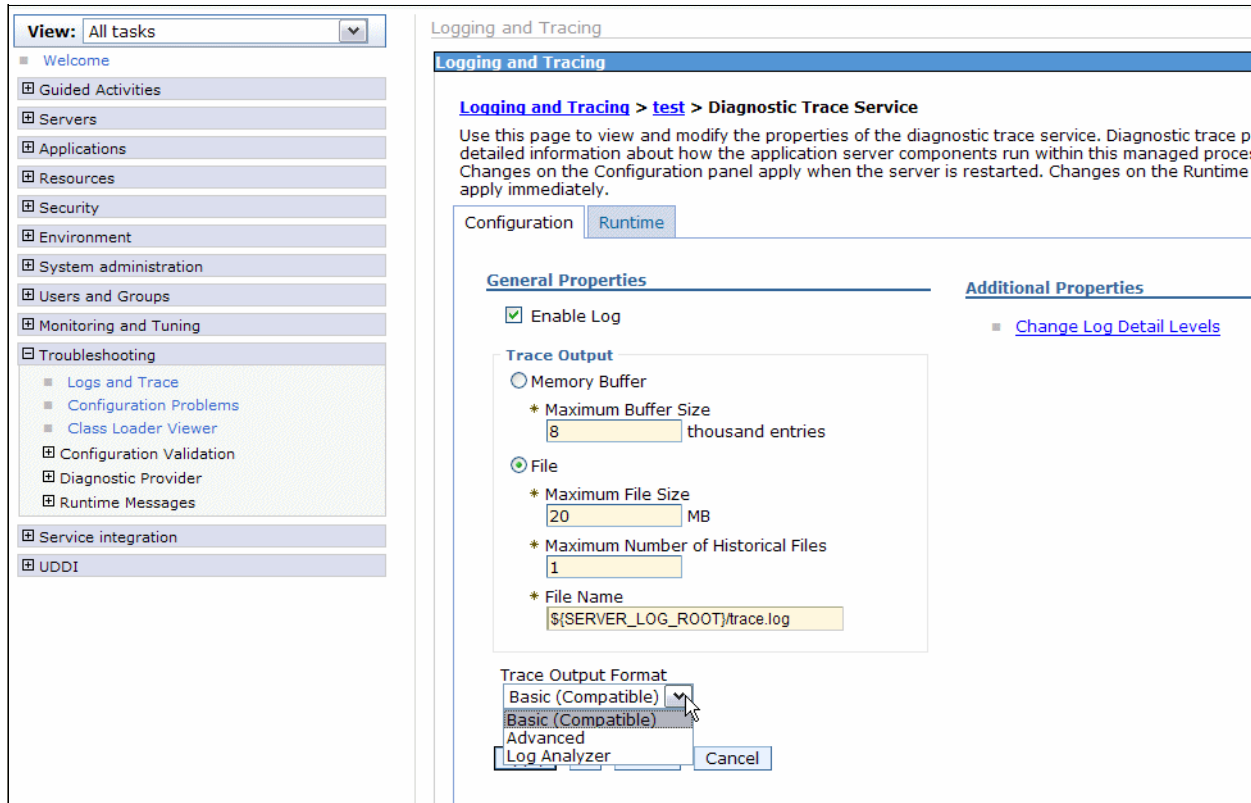

Figure D-1 Setting the tracing properties

9. Select the desired format for the generated trace.
10. Save the changed configuration.

To enter a trace string to set the trace specification to the desired state:

1. In the console navigation tree, click **Troubleshooting** → **Logs and Trace**.
2. Select a server name.
3. Click **Change Log Level Details**.
4. If **All Components** are enabled, you might want to turn it off, and then enable specific components.
5. Click a component or component group name. Select a desirable tracing level.
6. If you know the trace setting syntax, enter or paste a trace string in the trace string box.
7. Select **Apply**, and click **OK**.
8. Restart the server. For the Network Deployment edition, allow enough time for the nodes to synchronize, and then start the server.

## Additional IBM support resources

The following list contains additional IBM support resources:

- ▶ IBM Software Support Toolbar

There is a new toolbar that you can download to instantly search the IBM Support knowledge base and to search or browse for product downloads. Each IBM brand is

supported through this toolbar, but you can search brand-specific information from the toolbar's sub-menu.

You can download the IBM Support Software Toolbar from:

<http://www.ibm.com/software/support/toolbar/index.html>

► MustGather documents

MustGather documents aid in problem determination and save time resolving Problem Management Records (PMRs). Use the MustGather documents to gather general WebSphere Application Server information or to gather component specific information.

The MustGather documents can be found at:

<http://www-1.ibm.com/support/docview.wss?rs=180&uid=swg21145599>

► IBM Support Assistant

If you have the IBM Support Assistant tool, you can export your system data to a .zip file and have that file available for IBM support. See "Submitting a problem report to IBM" on page 429 for more information.



## **Web enablement using IBM Express Runtime Web Environments for i5/OS**

This appendix contains information about the IBM Express Runtime Web Environments for i5/OS product (5733-SO1). IBM Express Runtime Web Environments for i5/OS is a new product for System i customers and is designed to reduce the complexity of moving to and using a Web environment for your applications.

Of special interest to IBM Business Partners and Independent Software Vendors (ISVs), in this appendix, we also discuss how to create a solution that is similar to that of IBM Express Runtime Web Environments for i5/OS using free downloadable tools from the IBM PartnerWorld® Web site.

# Overview of IBM Express Runtime Web Environments for i5/OS

Does the idea of modernizing your RPG applications seem daunting? Are you overwhelmed with the complexity of moving your applications into a Web environment? If so, there is a new (free!) product that is available to System i customers, which helps simplify the daunting task of installing and configuring a Web environment.

IBM Express Runtime Web Environments for i5/OS (5733-SO1) provides an integrated package of software products that you install and configure to your i5/OS using a wizard.

The product does the following:

- ▶ Installs V5R4 iSeries Access for Web (including PTFs), 5722-XH2
- ▶ Installs WebSphere Application Server - Express. Two versions of Express Runtime Web Environments for i5/OS V5R4 are available:
  - V1R1M0 contains WebSphere Application Server-Express V6.0 (order Web Enablement's feature 5905 for CDs and 5906 for a DVD)
  - V1R2M0 contains the newer WebSphere Application Server-Express V6.1 (order feature 5907 for CDs and 5908 for a DVD)
- ▶ Installs V5R4 IBM HTTP Server (including PTFs), 5722-DG1
- ▶ Configures a WebSphere Application Server profile and an HTTP server instance, generates the WebSphere Application Server plug-in, and starts both servers
- ▶ Configures iSeries Access for Web
- ▶ Installs and configures an icon on the Windows workstation desktop that links to a First Steps static HTML Web page. The First Steps Web page is designed to provide an easy way for you to get started using what the wizard deployed to your i5/OS.

The product includes several sample Web applications. Each Web application modernizes the flight400 application, a well-known sample RPG application. The flight400 application is installed as part of IBM Express Runtime Web Environments for i5/OS.

The included sample Web applications are as follows:

- ▶ Host Access Transformation Services (HATS)

A sample application that demonstrates the presentation of an RPG program named flight400, which was modernized using HATS.
- ▶ WebFacing

A sample application that demonstrates the presentation of flight400, which was modernized using WebFacing.
- ▶ Web Services

This sample application queries flight400 by accessing it using a Web Service.

After the environment is successfully deployed, an icon is placed on your Windows workstation desktop from which you can access the Web environment.

## Web Enablement Environment

The IBM Express Runtime Web Environments for i5/OS product (5733-SO1) have one option, Web Enablement Environment, V5R4M0.

The Web Enablement Environment significantly reduces the time that is necessary to set up a Web environment on an i5/OS. It installs all of the necessary middleware, fix packs, and

program temporary fixes (PTFs). It also automatically configures the Web environment for immediate use of the following types of applications:

- ▶ J2EE applications
- ▶ Web services applications
- ▶ WebFacing applications
- ▶ Host Access Transformation (HATS) applications
- ▶ WebFacing Deployment Tool with HATS Technology (WDHT) applications
- ▶ V5R4 iSeries Access for Web applications

## Ordering and distribution

IBM Express Runtime Web Environments for i5/OS is offered as a feature of IBM Web Enablement for i5/OS (5733-WE2), which is shipped by default when you order i5/OS V5R4. You can order all WebSphere Application Server products through the 5733-WE2 product.

IBM Express Runtime Web Environments for i5/OS is distributed by a CD or DVD. You can only run these CDs or DVDs on a Windows workstation.

Alternatively, you can order IBM Express Runtime Web Environments for i5/OS electronically through the IBM Electronic Software Delivery Web site. See the following Web site for more information:

<http://www.ibm.com/servers/eserver/ess>

IBM Express Runtime Web Environments for i5/OS is available free of charge, because you are already entitled to V5R4 embedded products at no cost.

## System prerequisites

Table E-1 describes i5/OS system prerequisite products and options for the IBM Express Runtime Web Environments for i5/OS product.

*Table E-1 i5/OS system prerequisites*

Prerequisite	Additional information
i5/OS V5R4 (5722-SS1)	The product requires the installation of i5/OS V5R4. It does not run on previous i5/OS (OS/400) releases.
Extended Base Directory Support (5722-SS1, option 3)	
AFP Compatibility Fonts (5722-SS1, option 8)	
Host Servers (5722-SS1, option 12)	
Qshell (5722-SS1, option 30)	
Java Developer Kit 1.4 (5722-JV1, *BASE, option 5, and option 6)	
Toolbox for Java (5722-JC1)	
TCP/IP Connectivity Utilities (5722-TC1)	Your i5/OS system must be configured for TCP/IP and DNS.

Prerequisite	Additional information
iSeries Access Family (5722-XH1)	The product installs iSeries Access for Web (5722-XH2), which is dependent on the iSeries Access Family (5722-XW1) product. However, you can install the iSeries Access Family product on a different system than the system on which IBM Express Runtime Web Environments for i5/OS is deployed.

Table E-2 describes Windows workstation prerequisite products and options for the IBM Express Runtime Web Environments for i5/OS product.

Table E-2 Windows workstation prerequisites

Prerequisite	Additional information
Windows operating system	IBM Express Runtime Web Environments for i5/OS operates runs on the following operating systems: <ul style="list-style-type: none"> <li>▶ Windows XP Professional SP2</li> <li>▶ Windows 2000 Server SP4</li> <li>▶ Windows 2000 Advanced Server SP4</li> <li>▶ Windows 2000 Professional SP3</li> <li>▶ Windows Server® 2003, Standard Edition SP1</li> <li>▶ Windows Server 2003, Enterprise Edition SP1</li> </ul>
TCP/IP and DNS	Your workstation must be configured for TCP/IP and DNS
Web browser	IBM Express Runtime Web Environments for i5/OS works with the following Web browsers: <ul style="list-style-type: none"> <li>▶ Windows Internet Explorer 6 or later</li> <li>▶ Firefox 1.5 or later</li> </ul>
Minimum hardware requirements	IBM Express Runtime Web Environments for i5/OS requires the following minimum hardware: <ul style="list-style-type: none"> <li>▶ 512 MB of memory—1 GB recommended</li> <li>▶ Intel® Pentium® III class processor with a minimum clock speed of 600 MHz. Intel Pentium IV class processor with a minimum clock speed of 1.2 GHz is recommended.</li> <li>▶ Local area network (LAN) connection</li> <li>▶ SVGA monitor with a minimum 1024 x 768 video resolution configured to display a minimum color depth of 256 colors</li> <li>▶ 1.5 GB free disk space</li> </ul>

We also recommend the PTFs in Table E-3.

Table E-3 Recommended PTF levels

Component	PTF number
i5/OS Cumulative PTF Group	SF99540 Level 6066 or later
Java Group PTF	SF99291 Level 2 or later
DB2 UDB for iSeries Group PTF	SF99504 Level 2 or later

# Installing IBM Express Runtime Web Environments for i5/OS

You install the IBM Express Runtime Web Environments for i5/OS product through a GUI interface, which provides you with an interactive, step-by-step approach for installing the product.

Your i5/OS user profile must have \*SECOFR authority and all special authorities to deploy the environment to the i5/OS.

**Note:** When the installation is finished, a new HTTP server instance and WebSphere Application Server profile are created. You cannot use an existing HTTP server instance or WebSphere Application Server profile when you install the product.

Perform the following steps to install the product:

1. If TCP/IP is not started or if you do not know if TCP/IP is started, enter the Start TCP/IP (STRTCP) command on the CL command line.
2. Verify that the host server jobs are started on your i5/OS. The host server jobs allow the installation code to run on your i5/OS.

Enter the following command on the CL command line:

```
STRHOSTSVR SERVER(*ALL)
```

3. Insert the **IBM Express Runtime Web Environments for i5/OS** CD-ROM or DVD into the CD-ROM or DVD drive of your Windows workstation that is connected to your i5/OS.

There are three CDs or one DVD required for the installation of IBM Express Runtime Web Environments for i5/OS.

4. Double-click **launchpad.exe** to begin installation, if necessary.
5. The Installation Launch Pad panel appears. You can choose to review the readme file, deploy the solution, or exit the Launch Pad from this panel. To start the Deployment Wizard, click **Run Deployment Wizard**, as shown in Figure E-1.

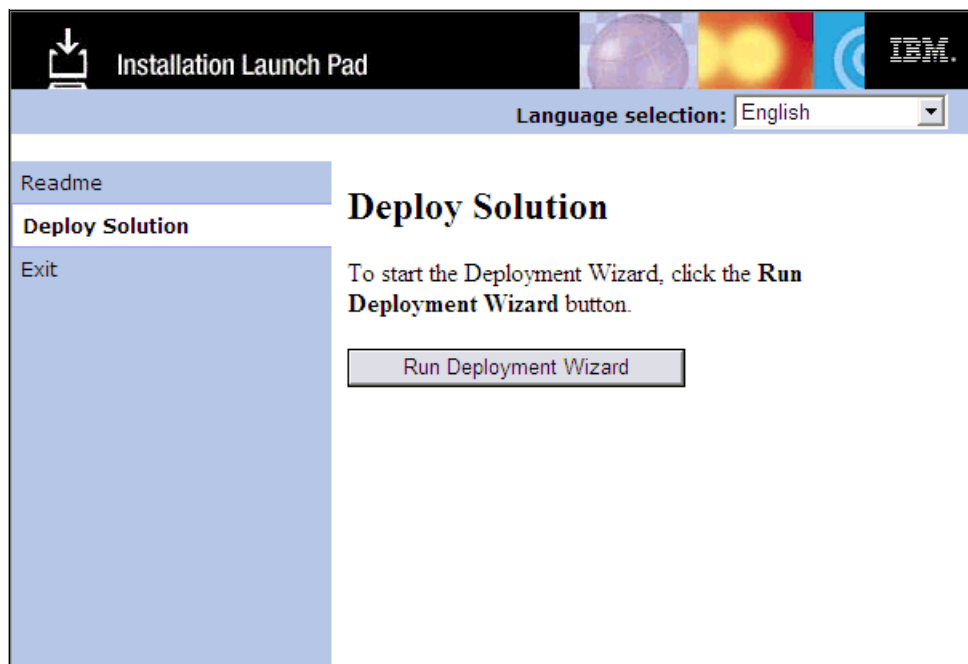

Figure E-1 The Installation Launch Pad panel

6. On the License panel, click the radio button to accept the terms of the licence agreement, and click **Next**. You must accept each product's license agreement.
7. Click **Next** to proceed from the Welcome panel.
8. On the Select Tasks panel, select the installation tasks. The first task deploys the product to your i5/OS. If you do not select the first task, the product will not install. The second task places an icon on the Windows workstation desktop to provide access to the product.

We recommend that you select both tasks. Click **Next**.

9. On the Specify Target Computers - Web Enablement Environment panel (shown in Figure E-2), specify the following information:
  - a. In the Target Computer field, specify the name of your i5/OS.
  - b. In the User ID field, specify your i5/OS user ID.
  - c. In the Password field, specify your i5/OS password.

You can also test the connection to your server from this panel. Click **Next**.

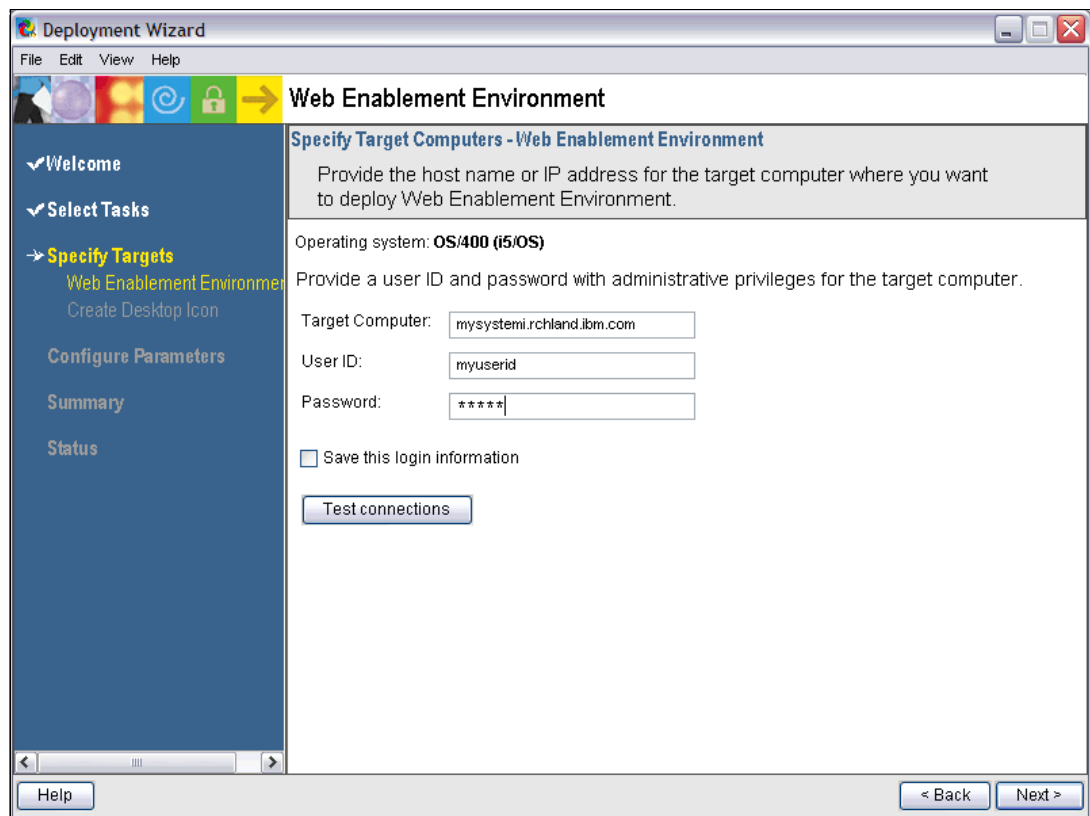

Figure E-2 The Specify Target Computers - Web Enablement Environment panel. This is where you specify your i5/OS name, user ID, and password.

10. On the Specify Target Computers - Create Desktop Icon panel (Figure E-3), in the Target Computer field, specify the name of your Windows workstation. If you specify **localhost**, you do not have to specify your user ID and password.

You can also test the connection to your workstation from this panel. Click **Next**.

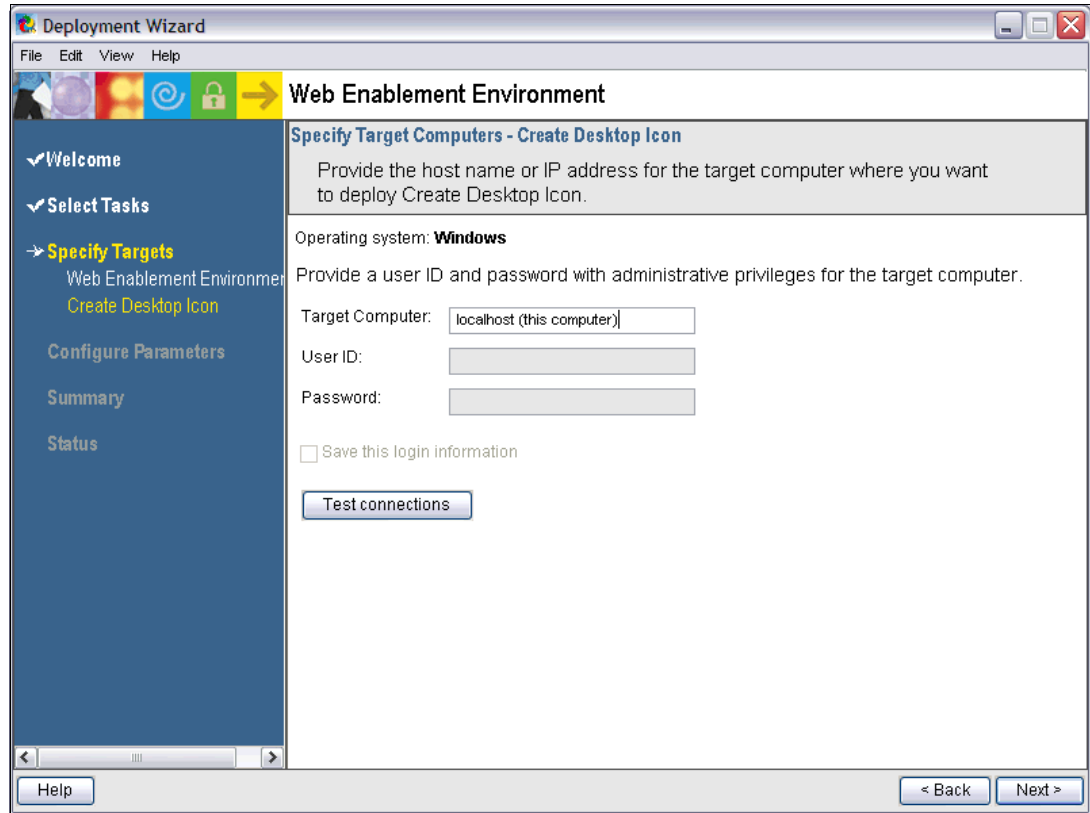

Figure E-3 The Specify Target Computers - Create Desktop Icon panel. This is where you specify your Windows workstation name, user ID, and password.

11. On the Configure Parameters - HTTP and application server names and ports panel (Figure E-4), specify configuration information for Web Enablement Environment:

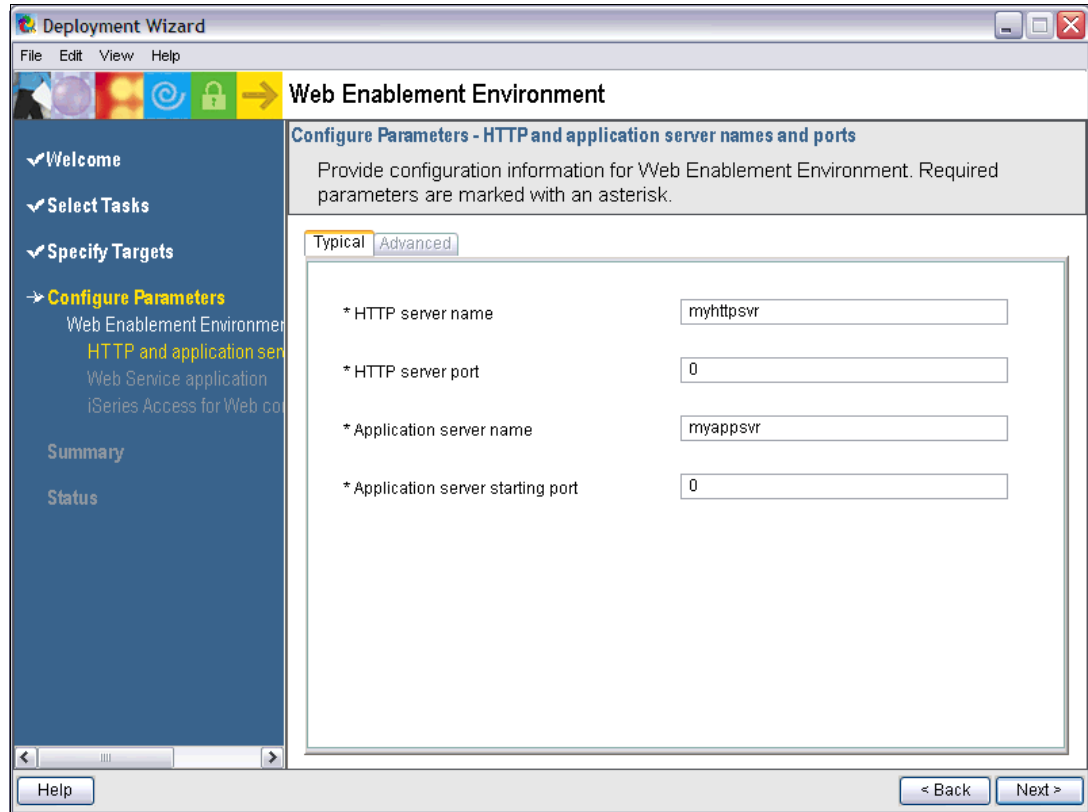

Figure E-4 The Configure Parameters - HTTP and application server name panel

- a. In the HTTP server name field, specify the new HTTP server name. You cannot use an existing HTTP server instance.
  - b. In the HTTP server port field, specify the port on which you want the HTTP server instance to run. If you specify port 0, the port is automatically selected during deployment.
  - c. In the Application server name field, specify the new WebSphere Application Server profile name. You cannot use an existing application server profile.
  - d. In the Application server starting port field, specify the port on which you want the application server profile to run. If you specify port 0, the port is automatically selected during deployment.
  - e. Click **Next**.
12. On the Configure Parameters - Web Services application panel, you must enter your i5/OS user ID and password again in order to programmatically invoke the flight400 program. Click **Next**.
13. On the Configure Parameters - iSeries Access for Web panel, specify the i5/OS that iSeries Access for Web is to connect. A value of `localhost` causes iSeries Access for Web to connect and access resources from the same i5/OS that the Web environment is deployed. If you want to access resources from another i5/OS, enter the fully-qualified system name. The iSeries Access Family (5722-XW1) product must be installed on the i5/OS where iSeries Access for Web will connect. Click **Next**.

14. Review your information about the Summary panel (Figure E-5), and click **Deploy all**.

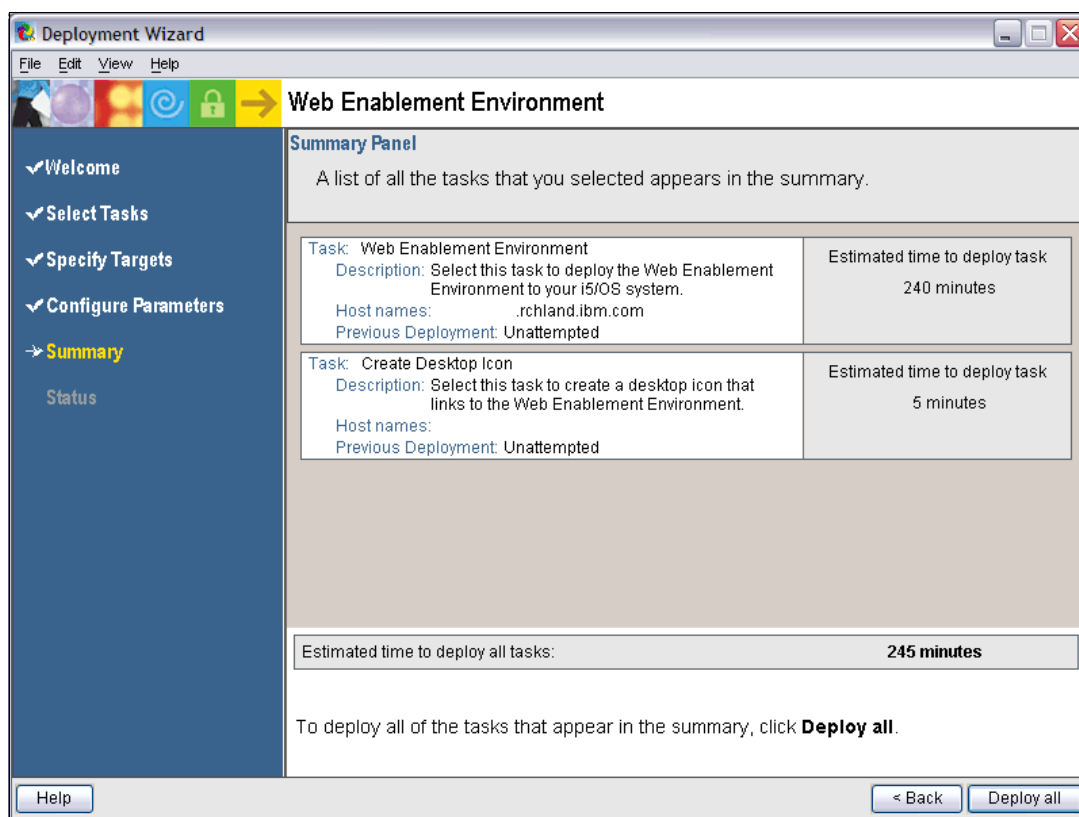

Figure E-5 The summary panel

**Note:** A successful deployment of IBM Express Runtime Web Environments for i5/OS can take 30 minutes to 4 hours, depending on what products are previously installed, the speed of your system, and the speed of your network. If a product included in the environment is already installed on your i5/OS, that product is not reinstalled.

## Deploying IBM Express Runtime Web Environments for i5/OS

Figure E-6 on page 448 shows a successful installation and deployment of IBM Express Runtime Web Environments for i5/OS.

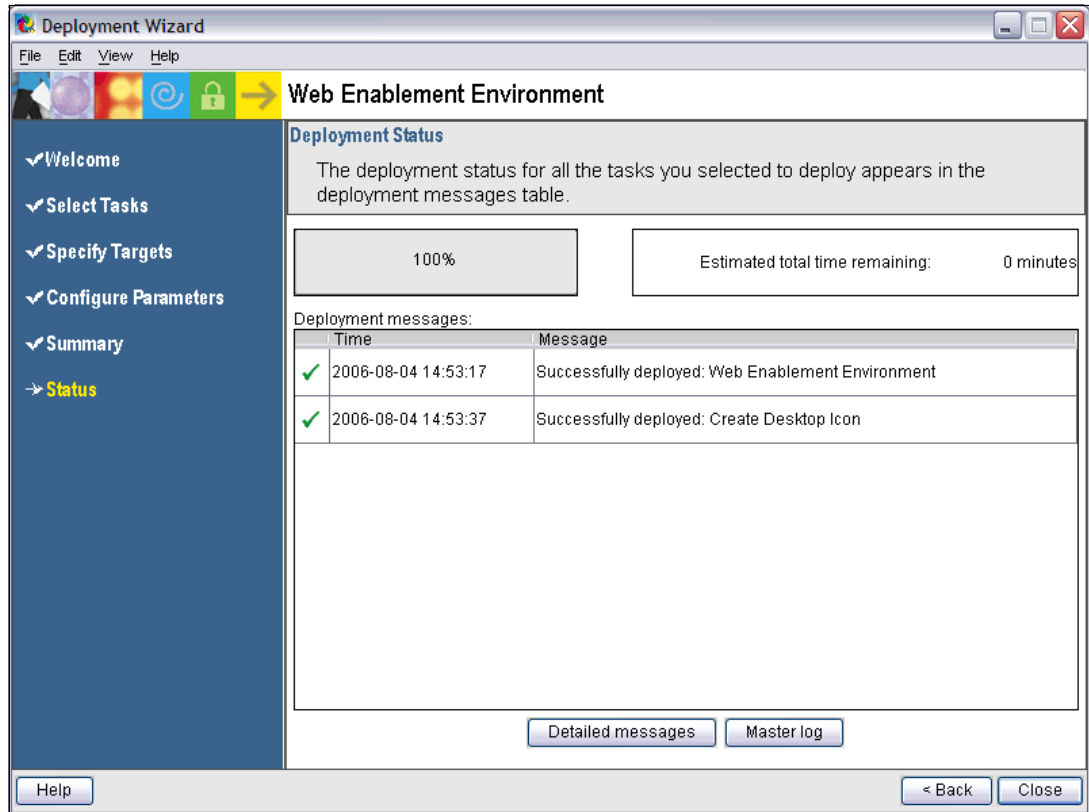

Figure E-6 A successful deployment panel

Click **Close** to close the Installation Launch Pad.

## FirstSteps

As a result of deployment, an icon named *Web\_Enablement\_Environment\_V5R4M0* is placed on your Windows workstation desktop. This icon is your entry point to the IBM Express Runtime Web Environments for i5/OS product and is a local Web page called FirstSteps, shown in Figure E-7 on page 449.



Figure E-7 The FirstSteps Web page

## IBM Web Administration for i5/OS

If you want to manage your newly-created Web environment beyond the sample applications that are installed with IBM Express Runtime Web Environments for i5/OS, use the IBM Web Administration for i5/OS interface. This interface allows you to easily start and stop servers, install your own Web applications, and manage the Web environment.

The easiest way to access the IBM Web Administration for i5/OS interface is from the FirstSteps Web page:

1. Double-click the **Web Enablement Environment, V5R4M0** icon on your desktop to open the FirstSteps Web page.
2. Click the **IBM Web Administration for i5/OS** link.

For alternate ways to access the IBM Web Administration for i5/OS interface, see 4.2.1, "Starting IBM Web Administration for i5/OS" on page 89.

## iSeries Access for Web

IBM Express Runtime Web Environments for i5/OS has also installed and configured iSeries Access for Web. Use iSeries Access for Web to leverage business information, applications,

and resources across an enterprise by extending the i5/OS resources to the client desktop through a Web browser.

The easiest way to access the iSeries Access for Web interface is from the FirstSteps Web page:

1. Double-click the **Web Enablement Environment, V5R4M0** icon on your desktop to open the FirstSteps Web page.
2. Click the **iSeries Access for Web** link.

For alternate ways to access the iSeries Access for Web interface, see the following Web page located in the V5R4 iSeries Information Center:

<http://publib.boulder.ibm.com/InfoCenter/series/v5r4/topic/rzamm/rzammaccessweb.htm>

## Sample applications

Three sample applications are provided with IBM Express Runtime Web Environments for i5/OS. These applications were modernized for the Web environment using various methods.

Use the FirstSteps Web page to access the sample applications. However, it may be helpful to view the RPG application before you look at the modernized applications.

To access the flight400 RPG program, perform the following steps:

1. Sign on to your i5/OS.
2. Enter CHGCURLIB CURLIB(flight400) on the CL command line to change to the flight400 library.
3. Type GO FRSMAN on the CL command line to start the application.
4. When you finish looking at the way the RPG application is presented, go back to the FirstSteps Web page, and click the links for the three different modernized applications. They provide a good representation of the types of things you can do with your RPG applications.

**Note:** The WebFacing version of the flight400 application only works with Microsoft Internet Explorer.

## Using IBM Express Runtime Web Environments for i5/OS

The main advantage of IBM Express Runtime Web Environments for i5/OS is that it is an easy way to install all the components necessary for a working Web environment. Put another way, it is an easy way to quickly get up and running.

Use the FirstSteps page to access your IBM Web Administration for i5/OS console. IBM Web Administration for i5/OS is a helpful tool for i5/OS customers because it provides a consolidated console for most of your HTTP server and application server daily tasks. You can use the IBM Web Administration for i5/OS console to manage your Web environment, install other applications, or install other applications that you develop.

See Chapter 4, “Day-to-day operations” on page 85 for more information about performing daily tasks with IBM Web Administration for i5/OS.

# Troubleshooting IBM Express Runtime Web Environments for i5/OS

If the deployment of IBM Express Runtime Web Environments for i5/OS fails, check the following:

- ▶ Do you have iSeries Access Family (5722-XW1) installed?
- ▶ Do you have the appropriate authorities on your i5/OS user profile? You must have \*SECOFR with all special authorities to deploy the product.
- ▶ Are the specified ports available on your i5/OS?
- ▶ Do the HTTP server instance and WebSphere Application Server profile names already exist on your system?

If you still have a failure, analyze the detailed messages of the Master log to determine the cause of the problem. Whether or not a deployment completes successfully, the temporary setup files needed for the deployment are automatically removed by default from your i5/OS. Debugging may be easier if these files are retained.

Use the Deployment Wizard to prevent these files from being removed. Perform the following steps:

1. On the Deployment Wizard Summary panel (Figure E-5 on page 447), select **Edit** → **Preferences**.
2. Click **Target Computer Settings**.
3. Use the Target Computer menu to select the name of your i5/OS, and select **Do not remove setup file when deployment is complete**.
4. Click **OK**.
5. Deploy the environment created with the Deployment Wizard. When deployment is finished, the temporary setup files are left on your i5/OS in the /QIBM/UserData/rxa\_ia/IIA directory.

After the problem is corrected, rerun the installation using a new name for the WebSphere Application Server profile and the HTTP server instance.

Refer to the IBM Express Runtime Web Environments for i5/OS readme file for detailed troubleshooting information and for information about how to uninstall IBM Express Runtime Web Environments for i5/OS.

## For Business Partners and ISVs: Applying the IBM Express Runtime Web Environments for i5/OS concept to your business

If you are an IBM Business Partner or Independent Software Vendor (ISV), you may be wondering how you can develop such an easy solution for your customers as well. A product, such as IBM Express Runtime Web Environments for i5/OS, gives easy access to the Web environment by making it easy to download and use the environment itself. The sample applications provide you with good information about how a Web-based application works, but as a Business Partner or ISV, you may want to develop and deploy your applications into a newly-created Web environment.

We have an answer for you, and it comes in the form of downloadable tools and a sample solution installer that includes source code from the IBM PartnerWorld Web site.

IBM Solutions Builder Express is centered on critical solution areas: business integration, business intelligence, content management, e-commerce, infrastructure, portal workplace. At its core, it provides solution overviews that detail solution concept and business value, solution architecture, recommended software, hardware and tools, an implementation skills assessment, task descriptions, and an estimated service hours guide for project planning. It also includes an implementation guide and technical assets, which include an implementation checklist, instruction, tips and techniques for solution installation and use, customization information, technology simulators and sample code, data, scripts, and configuration for a quick start. Finally, you can download a demo toolkit that offers a customizable presentation to be used at the end customer, video clips of solution, and a how-to document. This is where the Solution Assembly Toolkit (SAT) and Starting Point Solution Installers (SSI) tools fit in.

## Solution Assembly Toolkit

The Solution Assembly Toolkit (SAT) is a Rational-based tool that utilizes wrappers to comprise a solution. It also includes Rational Application Developer (RAD). SAT automates multiple products or PTF installation and updates on your target system. If you have multiple CDs or DVDs that need to be loaded, an SAT solution first loads the data and then deploys automatically over the next minutes and hours, which reduces the amount of time that you have to spend downloading a large, complex solution. The IBM Express Runtime Web Environments for i5/OS product was developed using SAT.

Additionally, SAT can plug into any Eclipse-based environment, including RAD and WebSphere Developer Studio Client (WDSC) for i5/OS.

Perform the following steps to download SAT free of charge from the PartnerWorld Web site:

1. Enter the following URL in your Web browser:

[https://www14.software.ibm.com/webapp/iwm/web/preLogin.do?lang=en\\_US&source=solutionassemblytk](https://www14.software.ibm.com/webapp/iwm/web/preLogin.do?lang=en_US&source=solutionassemblytk)

2. Sign in to the PartnerWorld Web site.
3. Select your installation platform (Figure E-8 on page 453), and click **Continue**.

**IBM Solution Assembly Toolkit**

**Downloads**

To properly configure your download, please review the information below. Select the appropriate offering. When you are done, press the "Continue" button at the bottom.

Offering	Platform	Format
<input type="radio"/> <b>IBM Solution Assembly Toolkit for Windows</b> Version 2.2.1  Languages: Chinese Simplified Chinese Traditional English U.S. French German Italian Japanese Korean Portuguese Brazilian Spanish	Windows	download
<input type="radio"/> <b>IBM Solution Assembly Toolkit for Linux</b> Version 2.2.1  Languages: Chinese Simplified Chinese Traditional English U.S. French German Italian Japanese Korean Portuguese Brazilian Spanish	Linux	download
<input type="radio"/> <b>IBM Solution Assembly Toolkit for additional deployment targets</b> Version 2.2.1  Languages: Chinese Simplified Chinese Traditional	AIX HP-UX i5/OS V5 OS/400 V5 Linux Linux for System p Solaris (Sun)	download

**Need help?**

- Sign up (English)
- Sign up Download
- Software support (English)

Figure E-8 Selecting SAT version

4. Provide answers to the IBM survey. View and accept the licence agreement by selecting **I agree**, and click **I confirm**.
5. Select your version, and click **Download now**.
6. When the download of the zip file completes, extract the zip files, using a zip compression utility (PKZIP, WinZip, or InfoZip), to a temporary directory, for example C:\Downloads\satoolkitV2-1-2.

**Note:** Do not extract the files into a directory name that contains spaces.

7. After it is extracted, run the Solution Assembly Toolkit's launch pad executable file (launchpad.exe) to start the launch pad.
8. When the launch pad is displayed, click **Install the Solution Assembly Toolkit**.

9. Refer to the Solution Assembly Toolkit Getting Started Guide for further installation, development, and deployment instructions.

## Starting Point Solution Installers

In addition to the SAT product, you can also download Starting Point Solution Installers (SSI) from the PartnerWorld Web site and learn how to use SAT to build your own solution.

SSIs are sample solutions that were created using SAT. They include the source code, which shows you how to programmatically install and configure a Web application into the application server. Think of SSIs as templates that show you how a solution is built, and apply that knowledge to build your own solution.

**Tip:** Besides the IBM Express Runtime Web Environments for i5/OS product, there is another product, IBM Express Runtime, that also provides additional wrappers, including source code. This product also installs and configures products, and it is available for purchase.

Perform the following steps to download SSI:

1. Enter the following URL in your Web browser:  
<https://www6.software.ibm.com/dl/sspi/sspi-p>
2. Sign in, and change any profile information. Click **Submit**.
3. Select what offering you want to download (Figure E-9 on page 455), and click **Continue**.

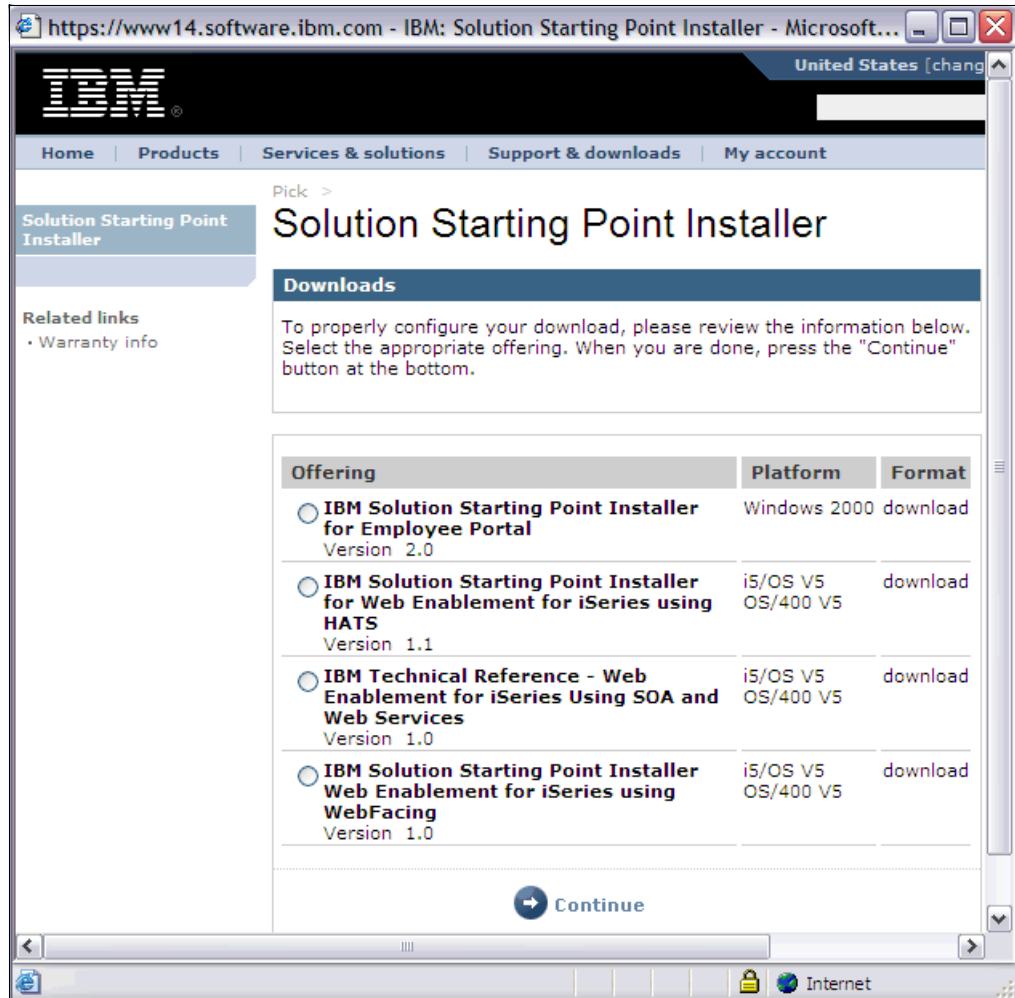

Figure E-9 Select the SSI offering you want to download. The offerings may not be available on all platforms.

4. To download using Download Directory, select the files you want to download, view and accept the license agreement by selecting **I agree**, and click **I confirm**.
5. When the download of the zip file completes, extract the .zip files, using a zip compression utility (PKZIP, WinZip, or InfoZip), to a temporary directory, for example C:\Downloads\ssi\_sample1.

**Note:** Do not extract the files into a directory name that contains spaces.

6. After it is extracted, you can import the SSI source code into your SAT environment. The source folder is on the last disk of the SSI installation. You can use this source code to create your own solutions.

In addition, more information about the SSI is in the info folder, which is located on the first disk of the SSI installation. Documentation includes an Installation Guide that explains how to deploy the SSI.

The value add of downloading an SSI is to view how a solution is created using the SAT tool. You can use the SSI as a template for how to create your own solution. You can customize the SAT tool and the SSIs that are available through the PartnerWorld Web site and add in your own application (such as a servlet). By combining all of the different components of the

SAT tool and your own solution, you can create a customized end-to-end installer for your product.

# Related publications

The publications listed in this section are considered particularly suitable for a more detailed discussion of the topics that are covered in this IBM Redbooks publication.

## IBM Redbooks

For information about ordering these publications, see “How to get IBM Redbooks” on page 458. Note that some of the documents referenced here may be available in softcopy only.

- ▶ *WebSphere Application Server V6.1: System Management and Configuration*, SG24-7304
- ▶ *WebSphere Application Server for iSeries V6: Building Advanced Configurations*, SG24-6637
- ▶ *IBM Technology for Java Virtual Machine in IBM i5/OS*, SG24-7353
- ▶ *SQL Performance Diagnosis on IBM DB2 Universal Database for iSeries*, SG24-6654
- ▶ *IBM System i5 Handbook IBM i5/OS Version 5 Release 4 January 2006*, SG24-7486
- ▶ *WebSphere Application Server V6.1: Planning and Design*, SG24-7305
- ▶ *WebSphere Security Fundamentals*, REDP-3944

## Online resources

These Web sites are also relevant as further information sources:

- ▶ i5/OS Information Center, Version 5 Release 4  
<http://publib.boulder.ibm.com/infocenter/series/v5r4/index.jsp>
- ▶ WebSphere Application Server for i5/OS page  
<http://www.ibm.com/eserver/series/software/websphere/wsappserver/>
- ▶ WebSphere Application Server, Version 6.1 - Information Center  
<http://publib.boulder.ibm.com/infocenter/wasinfo/v6r1/index.jsp>
- ▶ IBM Systems Workload Estimator (Workload Estimator)  
<http://www-912.ibm.com/wle/EstimatorServlet>
- ▶ Java Diagnostics Guide 5.0  
<http://publib.boulder.ibm.com/infocenter/javasdk/v5r0/index.jsp>
- ▶ WebSphere Application Server product support  
<http://www.ibm.com/software/webservers/appserv/was/support/>
- ▶ IBM Support Assistant (ISA)  
<http://www-306.ibm.com/software/support/isa/>

## How to get IBM Redbooks

You can search for, view, or download Redbooks, Redpapers, Hints and Tips, draft publications and Additional materials, as well as order hardcopy Redbooks or CD-ROMs, at this Web site:

[ibm.com/redbooks](http://ibm.com/redbooks)

## Help from IBM

IBM Support and downloads

[ibm.com/support](http://ibm.com/support)

IBM Global Services

[ibm.com/services](http://ibm.com/services)

# Index

## Symbols

- \*BASE 304
- \*INTERACT 304
- \*MACHINE 304
- \*SPOOL 304
- .bin file 408
- .py 222

## Numerics

- 7463 (processor feature) 348

## A

- AboutThisProfile.txt 93
- Access administration console
  - Default method 121
  - Web Admin method 123
- Act - Inel column 302
- Act - Wait column 302
- Add Image Catalog Entry (ADDIMGCLGE) command 408
- ADDIMGCLGE (Add Image Catalog Entry) command 408
- Additional Settings (advisor) 361
- Additional Settings tab (advisor) 358
- Additional web application server settings 355
- addNode 139
- AdminApp 218
- AdminConfig 218
- AdminControl 218
- Administrative console 4
  - Command assistance 13
- Administrative Console Command Assist 219
- Administrative Scripting Commands 233
- administrative security 387
- AdminTask 218
- Advise window for Threads to process 355
- ANZJVM 310
- Apache JMeter 297
- Application Clients 52
- Application Response Measurement 341
- Application server resources 355
- Application Server Toolkit 52
  - Jython script file 230
  - Server connection 225
- Application server toolkit 14
- Applying WebSphere Application Server fixes 54
- ARM 341
- Associating IHS and WebSphere Application Server 167
- Associating IHS with the cell profile 187
- AST 224
- AST content assist 224
- AST content tip 224
- Autostart application servers 159

## B

- BeanScripting Framework 220
- Before start to install
  - Installation time 25
  - Review your system status 25
  - System availability 25
- BM Update Installer 52
- BSF 220

## C

- Cell profile 87
- CFGTCP 434
- CHGJOB 160
- chgown 377
- CHGRTGE 306
- Collection Services 298
- Collector tool 435
- Command assist tool 231
- Concurrently Active Threads 296
- Configuration of more HTTP servers 186
- Configuring deployment manager 135
- Configuring remote HTTP server instance 171
- connection pool 336
- Content Assist 236
- Content Tip 236
- core product files 88
- Create application server cell
  - Default Qshell method 134
- Create application server profile
  - Basic Qshell method 92
- Create application server profiles 137
- Creating a Jython Project 228
- CRTDUPOBJ 159
- CRTIMGCLG (Create Image Catalog) command 407
- cumulative PTF 399
- Current heap sizes 332
- Custom profile 87

## D

- Data Source 345
- data source 336, 360
- DataSource connection pools 332
- Day-to-day operations 88
- DB Fault 301
- DBC Resources tab (advisor) 358
- deadlock 325
- Default installation root 12
- default profile template 86
- Default profiles 86
- Delete application server profile
  - Default Qshell method 127
  - Web Admin method 128
- Deployment manager profile 87

- deployment manager profile
  - creation 135
- Deprecated features 9
- disk configuration 298
- Display System Value (DSPSYSVAL) QPRCFEAT 348
- DMPJVM 310
- download basket 401
- DSPPTF 434
- DSPSFWRSC 434
- dspwasinst 139, 152

## E

- e-mail notification 399
- enableJVM 381, 387
- EVTK tool 319, 322
  - overview 311
- EWLM 341
- export or import the performance profile (Web Performance Advisor) 347
- Exporting Jython Scripts 238
- Extensible Verbose GC Toolkit 311

## F

- Federating application profiles 138
- File Transfer Protocol (FTP) 399
  - install 407
  - order 400
- Find TCP/IP ports
  - Default Qshell method 151
  - Web Admin method 152
- Fix Central 399
  - e-mail notification 399
- Frequency of the backup 375
  - WebSphere Application Server 376
  - WebSphere Application Server application data 376
  - WebSphere Application Server applications 376
  - WebSphere Application Server environment configuration 376
  - WebSphere Application Server licensed products 376
- FTP (File Transfer Protocol) 399

## G

- Garbage Collection cycles 309
- generic JVM arguments 392
- Getting content assistance and tips in the Jython editor 236
- group PTF 399

## H

- Hardware Management Console 350
- Hardware requirements 3
- heap
  - settings 320
- heap size 306
- historyInfo script 416
- HMC 350
- http profile 172

- HTTP server 341, 344
- HTTP server profile template 86

## I

- i5/OS 325
- i5/OS Tasks 339
- IBM Developer Kit for Java DJBC driver - Native JDBC driver 360
- IBM Express Runtime Web Environments for i5/OS 439
  - Deploying 447
  - FirstSteps 448
  - Information for ISVs 451
  - Installing 443
    - options 440
    - Overview 440
    - Prerequisites 440–441
    - Sample applications 450
    - Troubleshoot 451
- IBM Installation Factory 52, 61
  - Add Script 70
  - build definition 62
  - Build Information 65
  - Connected Mode 63
  - Customized Installation Package (CIP) 61
  - disconnected mode 63
  - Feature Selection 67
  - ifgui command 62
  - Install and Uninstall panel 69
  - Installing 61
  - Maintenance Packages panel 67
  - order of your scripts 70
  - Package Information panel 64
  - Product Installation Image panel 66
  - Profile Customization 71
  - upgrade an existing installation 61
  - Using 62
  - Verify Maintenance Packages 67
- IBM Jacl to Jython Conversion Assistant 219
- IBM Rational Performance Tester 297
- IBM Software Support Toolbar 437
- IBM Solutions Builder Express 452
- IBM Support Assistant 325, 421, 438
  - configure 422
  - install 422
  - overview 422
  - portable collector 429
  - prerequisites 422
  - Search product sites 429
  - Search support information 428
  - start 427
  - submit PMR 429
  - troubleshoot 431
  - uninstall 426
  - update 424
- IBM Technology for Java VM 379
- IBM Web Administration 90
- image catalog 407
- individual PTFs 399
- ineligible state 302
- Installation Checklist 32

- Installation Factory 10
- Installing fixes.Installing Group PTFs 53
- Installing fixes.Installing Individual Fixes 414
- Installing fixes.Installing Update Installer 54
- Installing other components 52
- integrated file system
  - directory 404
- Invoking wsadmin 220
- IPTest 435
- ISA 421
- iSeries Navigator Tasks on the Web 344
- ivt script 60

## J

- J2EE specifications 2
- J9 379
- Jacl 219
- jacl 221
- Jacl to Jython Conversion Assistant 236
- Jacl2Jython 236–237
- Java and Process Management 307
- Java Heap 327
- Java toolbox driver interface 345
- Java version 356
- Java virtual machine (JVM) 310
- java.lang.OutOfMemory 295
- javacore 323
- Javadump 324
  - creating 324
  - files
    - capturing 324
  - importing into ThreadAnalyzer tool 325
- JAVAGC indicator 332
- JDBC
  - performance considerations 338
- JDBC (Java Database Connectivity) parameters 355
- JDBC Provider 345
- JDBC provider 360
- JSF 1.1 13
- JSR 116 13
- JSR 168 13
- JVM (Java Virtual Machine) parameters 355
- JVM initial heap size 356
- JVM maximum heap size 356
- JVM settings Advise examples 357
- Jython 219
- jython 221

## K

- kill 323
- kill -QUIT 324

## L

- libj9gc23 332
- List application server profiles
  - Default Qshell method 126
- Load Image Catalog (LODIMGCLG) command 408
- Locate your files 364

- LODIMGCLG (Load Image Catalog) 408

## M

- manage application server and HTTP server attributes (Web Performance Advisor) 347
- Manage attributes 353
- manage system attributes (Web Performance Advisor) 347
- manageprofiles 93, 126, 128, 136
- Managing IHS from administrative console 194
- MDD4J tool 328
- memory 348
- Memory Dump Diagnostic for Java 328
- memory leak 328
- memory pool 304
- Mercury LoadRunner 297
- Migrating administrative Jacl scripts to Jython 236
- Monitor heap size 308
- Moving PTFs to an i5/OS system 404
- multiple PTFs 401
- MustGather 438

## N

- Native JDBC driver 338
- Non-DB Fault 301
- number of disk units 348

## O

- object leaks 308
- OpenSTA 297
- os400j9.systemlaunch.properties 395
- OutOfMemoryError occurs 327
- Overview
  - Administration 8
  - Application development environment 9
  - Installation 8
  - Packaging 8
  - Performance and tuning 14
  - Security 15

## P

- page swapping 302
- Performance Monitoring Infrastructure 362, 393
- Performance Setting Web page 352
- Performing Post Installation tasks 56
  - Configuring SQL jobs 58
  - Enter license information 56
- PEX 331
- PEX \*PROFILE 331
- Planning for WebSphere Application Server 17
- PMI 393
- pool 304
- Preparing i5/OS for Installation 35
  - Checking TCP/IP configuration 37
  - Checking your user profile authorization 38
  - Install prerequisite program temporary fixes 35
- Prerequisites for WebSphere Application Server on i5/OS 32

- Prerequisites for WebSphere Application Server on i5/OSSystem i and i5/OS.i5/OS optional software 34
- Prerequisites for WebSphere Application Server on i5/OSSystem i and i5/OS.System i and i5/OS software requirements 33
- Print PEX Report (PRTPEXRPT) command 331
- Process Definition 307
- Process Management 307
- Processor Accelerator 290
- processor feature 348
- Product co-existence 9
- Profile directories structure 86
- PRTPEXRPT (Print PEX Report) command 331
- PTF
  - installation 407
  - requirements 400
- PTF groups recommendation 339
- PTF tabs - Web Performance Advisor 349

## Q

- Qshell 5
  - creating a Javadump in 324
- QSQSRVR 297, 299
- QSQSRVR job 345, 360
- queryWASinstalls 364
- QZDASOINIT 297, 299
- QZDASOINIT job 345, 360

## R

- Rational Application Developer 7
- Recovery from a failure 376
- Redbooks Web site 458
  - Contact us xiii
- Remote - IBM Toolbox Java JDBC driver 360
- Removed features 9
- Request data 161
- requirements for i5/OS 380
- Resources tab (advisor) 358
- response time
  - effect of garbage collection on 320
- Restore /QIBM/WAS directory 377
- Restore application data 378
- Restore authorizations 377
- Restore configuration 377
- Restore Install directory 377
- Restore Install library 377
- Restore shared library 377
- RMI 221
- RSTLICPGM 374
- Running wsadmin script files 222

## S

- SAT 452
- Save Licensed products 373
- Save WebSphere Application Server 366
  - EJB's Persistence data 367
  - Export EAR files 371
  - Http configuration 368

- IFS files 369
- installation library 366
- Installed Applications 371
- Product Libraries 366
- QEJB 367
- QEJBSVR 367
- Saving Product data 369
- Saving the configuration 370
- User profiles 367
- Validation lists 368
- Save WebSphere Application Server.QSYS.LIB objects 366
- Save your data 375
- Saving WebSphere Application Server Network Deployment 372
- SAVLICPGM 373
- script files 222
- selecting a server
  - communications 20
  - memory 18
  - processor 18
  - storage 19
- Servlet Engine Thread Pool 296
- shared pool 304
- SHRPOOL1 304
- SIZECHG 310
- SOAP 139, 221
- SOAP port 138
- Solution Assembly Toolkit 452
- SourceForge Grinder 297
- SSI 452
- Start application server
  - Default Qshell method 107
- Start IBM Web Administration 89
- Starting application servers from within the cell 140
- Starting Point Solution Installers 452, 454
- startManager 136
- startServer 108
- Stop application server
  - Default Qshell method 113
- Stop application server profile
  - Web Admin method 114
- stopServer 114
- STRTCPSVR 89
- system CPW 348
- System i hardware requirements 33
- system model 348
- System Resources 350
- system thrashing 302
- System Values
  - QMAXACTLVL 291
  - QPFRADJ 291
  - QPRCMLTTSK 291
  - QTHDRSCADJ 291
  - QTHDRSCAFN 291
- System.err 143
- System.out 143
- SystemOut.log 390

## T

- thread pool 333
- thread pool settings 335
- Thread Pools 335
- ThreadAnalyzer 325
- ThreadAnalyzer tool 326
  - analyzing Javacore using 325
  - thread analysis 327
- throughput
  - effect of garbage collection on 320
- Tivoli Performance Viewer 332, 334, 336
- Toolbox driver 338
- Topologies
  - Application Server 21
  - Database Server 22
  - External HTTP 22
  - HTTP Plug-in 22
  - Stand Alone System 22
  - Three layer Install 23
  - Web Server 22
- topologies for WebSphere Application Server 21
- TPV 332
- trace 436
- Trade 6 performance benchmark sample 312
- transaction counts 344
- Troubleshooting
  - IBM support resources 437
  - WebSphere Application Server files 435
- troubleshooting tips 398
- Troubleshooting WebSphere Application Server 6.1 Installation 77
  - Connection failed 77
  - Miscellaneous problems 80
  - Prerequisites failed 79
  - Security issues 78
  - Silent install problems 79

## U

- Understanding your environment 364
- Uninstalling WebSphere Application Server 61
- Uninstalling WebSphere Application Server.DLTLICPGM 83

## V

- Vary Configuration (VRYCFG) command 407
- Verbose GC 309, 311
- Verify Image Catalog (VFYIMGCLG) command 408
- versionInfo 418
- VFYIMGCLG (Verify Image Catalog) command 408
- virtual optical device 407
- VRYCFG (Vary Configuration) 407

## W

- Wait - Inel column 302
- Web container 333
- Web enablement 439
- Web Environment area (advisor) 355
- Web Environment JVM settings 356

- Web Environment of Web Performance Advisor 353
- Web Performance Advisor 339, 347
  - performance attributes 346
- Web performance advisor 346
- Web Performance Monitor 339–340
- Web server configuration file 196
- Web server definition 169
- Web server log files 198
- Web server managed node 164
- Web server management 194
- Web server node 164
- Web server unmanaged node 164
- WebSphere administration command assist 223
- WebSphere Administrative Console 345, 391
- WebSphere Application Server 324
  - Administration tools 4
  - Development tools 7
  - enhancements 9
  - Hardware requirements 3
  - overview 1
  - Platform differences 8
  - runtime environment 2
  - software requirements 3
  - Subsystem 14
- WebSphere Application Server Installation 38
  - Accept the International Program License Agreement 40
  - Application server binaries and profiles path 42
  - Change the response file 49
  - Enable administrative security during the installation 43
  - First steps Console 47
  - GUI Installation 38
  - Install the Sample Applications 42
  - Installation Results panel 45
  - Installation Summary 44
  - Installation verification 47
  - Launch the installation wizard for WebSphere Application Server 39
  - Multiple Installations Directories 11
  - Multiple Installations Libraries 11
  - Progress panel screen 45
  - querywasinstalls 12
  - Remote Install 48
  - responsefile 48
  - Silent installations 48
  - start hosts servers 38, 49, 51
  - Start the server 48
- WebSphere Application Server Toolkit 224
- WebSphere Automation Tools 219
- WebSphere Enterprise Workload Manager 341
- WebSphere plug-ins 52
- Work with log files
  - Default method 143
- Work with System Activity 303
- Workload Estimator 20
- WRKACTJOB 299
- WRKDSKSTS 298
- WRKPTFGRP 434
- WRKSHRPOOL 304

WRKSYSACT 303  
WRKSYSVAL 434  
wsadmin 218  
wsadmin execution environment 219  
wsadmin help 223  
wsadmin.properties 220



**Redbooks**

# WebSphere Application Server for i5/OS Handbook: Version 6.1

(1.0" spine)

0.875" x 1.498"

460 <-> 788 pages







# WebSphere Application Server for i5/OS Handbook: Version 6.1



**Designed to be the ultimate resource for WebSphere support personnel**

**Covers both Base and Network Deployment editions**

**Contains tips to make your work more efficient**

The number of System i customers running one or more Web applications is growing quickly. By integrating WebSphere Application Server - Express to i5/OS, IBM opens a door to a world of Web applications for all System i customers. Establishing solid knowledge and best practices in installing, administering, and maintaining WebSphere Application Server becomes one of the most important tasks for the System i administrators and support personnel.

In this IBM Redbooks publication, we explore the latest WebSphere Application Server version to date, Version 6.1. We include instructions for performing numerous tasks around WebSphere Application Server for i5/OS: installing the product, working with the server and applications, tuning the performance, setting up security, and more. We strongly recommend this book for any technical professional who works with WebSphere Application Server. We designed this publication to help system architects, WebSphere administrators, and software developers.

## **INTERNATIONAL TECHNICAL SUPPORT ORGANIZATION**

### **BUILDING TECHNICAL INFORMATION BASED ON PRACTICAL EXPERIENCE**

IBM Redbooks are developed by the IBM International Technical Support Organization. Experts from IBM, Customers and Partners from around the world create timely technical information based on realistic scenarios. Specific recommendations are provided to help you implement IT solutions more effectively in your environment.

**For more information:**  
[ibm.com/redbooks](http://ibm.com/redbooks)

SG24-7221-00

ISBN 0738485608